



K A C O



new energy.

blueplanet hybrid 6.0 NH3 M2
blueplanet hybrid 8.0 NH3 M3
blueplanet hybrid 10.0 NH3 M3
blueplanet hybrid 12.0 NH3 M3

Manual

■ English translation of German original

 **Authorised electrician**
Important safety instructions



Android-APP



iOS-APP

These instructions form part of the device and must be observed. They are available online on our website and correspond to the current hardware version. The copyright for these application instructions is held solely by KACO new energy GmbH.

Legal provisions

The information contained in this document is the property of KACO new energy GmbH. Publication, in whole or in part, requires the written permission of KACO new energy GmbH.

KACO warranty

You can download the current warranty conditions from the Downloads folder on our website at <http://www.kaco-newenergy.com>.

Definitions on device designations

In this manual, the device “Photovoltaic feed-in inverter” is referred to as the device for ease of reading.

Trademarks

All trademarks are recognised, even if not explicitly identified as such. A lack of identification does not mean that a device or designation/logo is free of trademarks.

Software

This device contains open source software developed by third parties and in some cases licensed under GPL and/or LGPL. More details on this topic and a list of the open source software used, as well as the corresponding licence texts, can be found on the associated “**KACO NH Setup**” APP in the “Info” menu under “Imprint”, “Wi-Fi Stick Licences” and “Mobile APP Licences”.

Photovoltaic feed-in inverter

Table of contents

1	General information	1	7.8	Creating equipotential bonding.....	37
1.1	Notes regarding this document.....	1	7.9	Connecting the interfaces	38
1.2	More information.....	1	8	Commissioning	46
1.3	Layout of Instructions.....	1	8.1	Requirements	46
1.4	Target group.....	2	8.2	Preconditions relating to standards	46
1.5	Marking	3	9	Configuration and operation	46
2	Safety	4	9.1	Start condition.....	46
2.1	Intended use	6	9.2	Initial start-up.....	47
2.2	Protection features	7	9.3	Authorisation.....	47
3	Description of the device.....	8	9.4	Operating system and system configuration....	48
3.1	System layout.....	8	9.5	Signal elements	49
3.2	Integration in a parallel system.....	11	9.6	Connecting to the device.....	52
3.3	Integrated energy management	13	9.7	Menu of the Communication Device.....	55
3.4	Compatible accessories	16	9.8	Menu of Inverter	65
4	Technical data	17	9.9	Inverter parameter settings	70
4.1	Electrical data.....	17	9.10	Performing a firmware update.....	96
4.2	General data.....	18	9.11	Monitoring with “blueplanet smartcloud”	97
4.3	Environmental data.....	19	9.12	Information on dynamic feed-in.....	98
4.4	Accessories	19	10	Maintenance and troubleshooting	100
5	Transportation and Delivery	20	10.1	Visual inspection.....	100
5.1	Scope of delivery	20	10.2	Cleaning	100
5.2	Transporting the device	20	10.3	Shutting down for maintenance work / troubleshooting.....	101
5.3	Installation tool	21	10.4	Troubleshooting	102
6	Assembly and preparation.....	21	10.5	Error code.....	102
6.1	Choosing the installation location.....	21	10.6	Fault during connection set-up and search....	108
6.2	Unpacking the device	22	11	Decommissioning and dismantling	109
6.3	Fastening the mount	23	11.1	Switching off the device	109
6.4	Installing and securing the device	24	11.2	Disconnecting connections.....	109
7	Installation	25	11.3	Uninstalling the device	111
7.1	General information.....	25	11.4	Disassembling the device	112
7.2	Overview of connection area	25	11.5	Packaging the device	112
7.3	Making the electrical connection.....	25	11.6	Storing the device.....	112
7.4	Connecting the device to the power grid.....	26	12	Disposal.....	112
7.5	Connecting the EPS to the device	29	13	Service and warranty.....	112
7.6	Connecting the PV generator to the device	32	14	Appendix.....	113
7.7	Connecting the battery storage unit	35	14.1	EU Declaration of Conformity	113

1 General information

1.1 Notes regarding this document



WARNING

Improper handling of the device can be hazardous!

› You must read and understand the manual in order to install and use the device safely!

Other applicable documents

During installation, observe all assembly and installation instructions for components and other parts of the system. These instructions also apply to the device, associated components and other parts of the system.

Some of the documents required for the registration and approval of your system are included with the manual.

Retention of documents

These instructions and other documents must be stored near the system and be available at all times.

- The current version of the manual can be downloaded from www.kaco-newenergy.com.

English translation of German original

This document has been produced in several languages. The German version is the original version. All other language versions are translations of the original version.

1.2 More information

Links to more detailed information can be found at www.kaco-newenergy.com.

Document title	Document type
Technical data sheet	Device flyer
Dynamic feed-in limitation and blueplanet smartcloud with/without smart meter	Application Notes
Modbus protocol	Protocol
SunSpec information model reference	Zip file
Firmware package	Zip file
Software	Automatic update for iOS / Android app
EU Declaration of Conformity	Certificates
Country-specific certificates - Certification for specific subassemblies	Certificates

1.3 Layout of Instructions

1.3.1 Symbols used



General hazard



Fire and risk of explosion



Electrical voltage



Risk of burns



Earthing - ground conductor

1.3.2 Safety warnings symbols guide



DANGER

High risk

Failure to observe this warning will lead directly to serious injuries or even death.



WARNING

Potential risk

Failure to observe this warning may lead to serious injuries or even death.



CAUTION

Low-risk hazard

Failure to observe this warning will lead to minor or moderate injuries.

NOTE

Risk of property damage

Failure to observe this warning will lead to property damage.

1.3.3 Additional information symbols



NOTE

Useful information and notes

Information that is important for a specific topic or objective, but that is not safety-relevant.

1.3.4 Symbols for instructions

 Prerequisite for use.

1 Perform next step

2 Additional action sequence

⇒ Interim result of the action

» End result

1.4 Target group

All activities described in the document may only be carried out by skilled personnel who have the following qualifications:

- Knowledge about how an inverter functions and operates
- Knowledge of the Modbus specifications
- Knowledge of the SunSpec Modbus specifications
- Training in the handling of hazards and risks during the installation and operation of electrical units and plants.
- Education concerning the installation and start-up of electrical devices and systems.
- Knowledge of applicable standards and directives.
- Knowledge and adherence to this document with all safety notices.

1.5 Marking

You will find the name plate with the following data for service and other requirements specific to installation on the right side panel of the device:

- Device name
- Part number
- Serial number
- Date of manufacture
- Technical details
- Disposal information
- Certification marking, CE marking.



 KACO new energy Werner-von-Siemens-Allee 1 74172 Neckarsulm		blueplanet hybrid 12.0 NH3 M2 B1 WM OD IIIG0	
		Part number	1002103
		Serial number	12.0NH312XXXXXX Year Q4 / 23
Barcode: Serial number(Cide128)			
PV Input	Max PV Voltage	1100 V	
	Operating Voltage Range / Start Voltage	200 V - 950 V / 200 V	
	Mpp Voltage Range at Pnom	450 V - 850 V	
	Max PV Current (Isc)	2 x 30 A	
	Nominal PV Current (Inom)	2 x 20 A	
Battery Port	Voltage Range	120 V - 600 V	
	Max Charge / Max Discharge Power	12000 W / 12000 W	
	Max Charge / Max Discharge Current	30 A / 30 A	
	Battery Type	Lithium-ion (LiFePO4, NMC)	
Grid Port	Nominal Grid Voltage	220 V / 380 V (3/N/PE)	
		230 V / 400 V (3/N/PE)	
		240 V / 415 V (3/N/PE)	
	Nominal Grid Frequency	50 Hz / 60 Hz	
	Frequency Range	45 Hz - 65 Hz	
	Max Grid Output Power	12000 VA	
	Max Grid Output Current	19.2 A	
Max Grid Input Power	22000 VA		
Max Grid Input Current	32 A		
	Power Factor Range	0.8 cap - 0.8 ind	
EPS Port (Backup)	Nominal EPS Voltage	220 V / 380 V (3/N/PE)	
		230 V / 400 V (3/N/PE)	
		240 V / 415 V (3/N/PE)	
	Nominal EPS Frequency	50 Hz / 60 Hz	
	Max EPS Output Power (continuous off-grid)	12000 VA	
	Max EPS Output Power (peak off-grid)	24000 VA for 10 sec	
Max EPS Output Power (continuous on-grid)	22000 VA		
Max EPS Output Current (continuous on-grid)	32 A		
	Power Factor Range (off-grid)	0.8 cap - 0.8 ind	
Environment	Temperature Range	-25 °C - +60 °C / -13 °F - +140 °F	
	Protection Class / Ingress Protection	I / IP 66	
No Galvanic Separation / Ungrounded Arrays Only	Max Backfeed Current	0 A	
Hybrid PV Inverter	ARC Fault Circuit Protection	None	
Interface protection according to country specific requirements, details see manual			
			

Fig. 1. Name plate

2 Safety

DANGER

Lethal voltages are still present in the connections and cables of the device even after the device has been switched off and disconnected!

Coming into contact with the lines and/or terminals/busbars in the device can cause serious injury or death.



- › Do not open the device.
- › The device must be mounted in a fixed position before being connected electrically.
- › Comply with all safety regulations and current technical connection specifications of the responsible power supply company.
- › The device is only permitted to be mounted, installed and commissioned by a qualified electrician.
- › Switch off the grid voltage by turning off the external circuit breakers.
- › Do not touch the cables and/or terminals/busbars when switching the device on and off.
- › Check that all AC and DC cables are completely free of current using a clip-on ammeter.

DANGER

Danger to life due to high voltages of the PV array or the battery!

The DC cables connected to the battery or the PV array may be live. Touching the DC conductors or the live components can cause to lethal electric shocks. If you disconnect the DC connectors from the device under load, an electric arc may occur leading to electric shock and burns. › Do not open the device.



- › Do not touch non-insulated cable ends.
- › Do not touch the DC conductors.
- › Do not touch any live components of the device.
- › Do not open the device.
- › Observe all safety information of the battery manufacturer.
- › All work on the device must only be carried out by qualified personnel who have read and fully understood all safety information contained in this document and the user manual.
- › Disconnect the device from all voltage and energy sources and ensure it cannot be reconnected before working on the device.
- › Wear suitable personal protective equipment for all work on the device.

DANGER

Danger to life due to electric shock when touching live components in backup mode!

Even if the AC breaker and the PV switch of the inverter are disconnected, the parts of the system may still be live when the battery is switched on due to backup mode. › Do not touch non-insulated cable ends.



- › Do not open the device.
- › Disconnect the device from all voltage and energy sources and ensure it can not be reconnected before working on the device.

DANGER

Danger to life due to fire or explosion when batteries are fully discharged!

Danger to life due to fire or explosion when batteries are fully discharged !

- › Make sure that the battery is not fully discharged before commissioning the system.
- › Contact the battery manufacturer for further proceedings if the battery is fully discharged.



DANGER

Danger to life due to fire or explosion when batteries are fully discharged!

Danger to life due to fire or explosion when batteries are fully discharged !

- › Make sure that the battery is not fully discharged before commissioning the system.
- › Contact the battery manufacturer for further proceedings if the battery is fully discharged.



 **DANGER**



Danger to life due to burns caused by electric arcs through short-circuit currents!

Short-circuit currents in the battery can cause heat accumulation and electric arcs if the battery is short circuited or wrongly installed. Heat accumulation and electric arcs may result in lethal injuries due to burns.

- › Disconnect the battery from all voltages sources prior to performing any work on the battery.
- › Only use properly insulated tools to prevent accidental electric shock or short circuits during installation.
- › Observe all safety information of the battery manufacturer.

 **DANGER**



Danger to life due to electric shock when touching live system components in case of a ground fault!

If a ground fault occurs, parts of the system may still be live. Touching live parts and cables may result in death or lethal injuries due to electric shock.

- › Disconnect the device from voltage and energy sources and ensure it cannot be reconnected before working on the device.
- › Only touch the cables of the PV modules on their insulation.
- › Do not touch any parts of the substructure or frame of the PV array.
- › Do not connect PV strings with ground faults to the device.

 **WARNING**



Danger to life due to electric shock from destruction of the measuring device due to overvoltage!

Overvoltage can damage a measuring device and result in voltage being present in the enclosure of the measuring device. Touching the live enclosure of the measuring device results in death or lethal injuries due to electric shock.

- › Only use measuring devices with the measurement span higher than the DC input voltage range.

 **CAUTION**



Risk of burns due to high temperature.

Some parts of the enclosure can become hot during operation.

- › During operation, do not touch any parts other than the enclosure lid of the device.

 **CAUTION**



Risk of injury due to weight of device.

Injuries may result if the device is lifted incorrectly or dropped while being transported or mounted.

- › Transport and lift the device carefully. Take the weight of the device into account.
- › Wear suitable personal protective equipment for all work on the device.

 **NOTE**

Damage to the inverter due to electrostatic discharge.

Internal components of the inverter can be irreparably damaged by electrostatic discharge.

- › Ground yourself before touching any component.

NOTE



The country grid code set must be set correctly.

If you select a country grid code set which is not valid for your country and purpose, it can cause a disturbance in the PV system and lead to problems with the grid operator. When selecting the country grid code set, you

must always observe the locally applicable standards and directives as well as the properties of the PV system (e.g. PV system size, grid-connection point).

- › If you are not sure which standards and directives are valid for your country or purpose, contact the grid operator.

The electrician is responsible for observing all existing standards and regulations. The following points must be taken into account:

- Keep unauthorised persons away from the device and/or system.
- In particular, observe standard ¹“Requirements for special types of premises, rooms and installations -Solar photovoltaic (PV) power supply systems” in the respective regionally applicable version.
- Ensure operational safety by providing proper grounding, conductor dimensioning and appropriate protection against short circuiting.
- Observe all safety instructions on the device and in this manual.
- Switch off all voltage sources and secure them against being inadvertently switched back on before performing visual inspections and maintenance.
- When taking measurements on the live device:
 - Do not touch the electrical connections
 - Remove all jewellery from your wrists and fingers
 - Ensure that the testing equipment is in safe operating condition
- Modifications to the surroundings of the device must comply with the applicable national and local standards.
- When working on the PV generator, in addition to disconnecting this from the grid it is also necessary to switch off the DC voltage using the DC isolator switch on the device.

2.1 Intended use

The device is a transformerless hybrid inverter with 2 or 3 MPP trackers and a battery connection that feeds the direct current of the PV array into the connected battery or converts it to grid-compliant three-phase current and then feeds it into the utility grid. The device also can convert the direct current supplied by the battery into grid-compliant three-phase current. The device has a backup function that can continue to supply selected circuits with power from the battery or PV system in the event of a grid fault.

The device is built using state-of-the-art technology and in accordance with the recognized safety rules. Nevertheless, improper use may cause lethal hazards for the operator or third parties, or may result in damage to the device and other property.

The device is intended for indoor and outdoor applications and may only be used in countries for which it has been approved or for which it has been released by KACO new energy and the grid operator.

The device must only be connected with PV modules of protection class II (in accordance with IEC 61730, application class A). Do not connect any sources of energy other than PV modules to the device.

The device is not equipped with an integrated transformer and therefore has no galvanic isolation. The device must not be operated with PV modules which require functional grounding of either the positive or negative PV conductors. This can cause the device to be irreparably damaged. The device may be operated with PV modules with frames that require protective earthing.

The device must only be operated in connection with an intrinsically safe lithium-ion battery approved by kaco. The entire battery voltage range must be completely within the permissible input voltage range of the device.

Operate the device only with a permanent connection to the public power grid. The country and grid type selection must be commensurate with the respective location and grid type.

The requirements of the grid operator must be met for grid connection to take place. The permission of the relevant authorities may also be required in order to secure authorisation to connection to the grid.

1 Country	Standard
EU	Harmonised document - HD 60364-7-712 (European implementation of the IEC standard)

The device may only be operated with PV arrays (PV modules and wiring) of protection class II pursuant to IEC 61730, application class A.

The name plate must be permanently attached to the device.

Any other or additional use is not considered proper or intended use and can lead to an annulment of the device guarantee. This includes:

- Use of a distribution system that is not described (grid type)
- Use of sources other than PV-strings
- Mobile use
- Use in rooms where there is a risk of explosion
- Use in direct sunlight, rain or a storm or other harsh environmental conditions
- Use in an outdoor area that does not meet the environmental conditions set down in Technical Data > Environmental Data.
- Operation outside the specification intended by the manufacturer
- Overvoltage of over 1100 V on the DC connection.
- Modifying the device
- Standalone mode

2.2 Protection features

The following monitoring and protection functions are integrated in the device:

- RCMU (Residual Current Monitoring Unit)
- Overvoltage conductor / varistor to protect the power semiconductors from high-energy transients on the grid and generator sides.
- System for monitoring the device temperature.
- EMC filters to protect the inverter from high-frequency grid interference.
- Grid-side grounded varistors to protect the device against burst and surge pulses.
- Anti-islanding detection according to the current standards.
- Insulation detection / residual current monitoring and shutdown function to detect insulation faults.



NOTE

If the device is connected, the overvoltage conductors / varistors contained in the device have an impact on the electrical system insulation resistance test as per HD 60364-6 / IEC 60364-6 Low-voltage installations-Part 6: Verification.

IEC 60364-6 6.4.3.3 describes two options for this case. The first option is to disconnect devices with an overvoltage conductor or, if this is not practicable, then the test voltage can be reduced to 250 V.

3 Description of the device

3.1 System layout

The device is a high-quality inverter which can convert solar energy to AC energy and store energy into battery. The device can be used to optimize self-consumption, store in the battery for future use or feed into public grid.

The basic application of this device as follow:

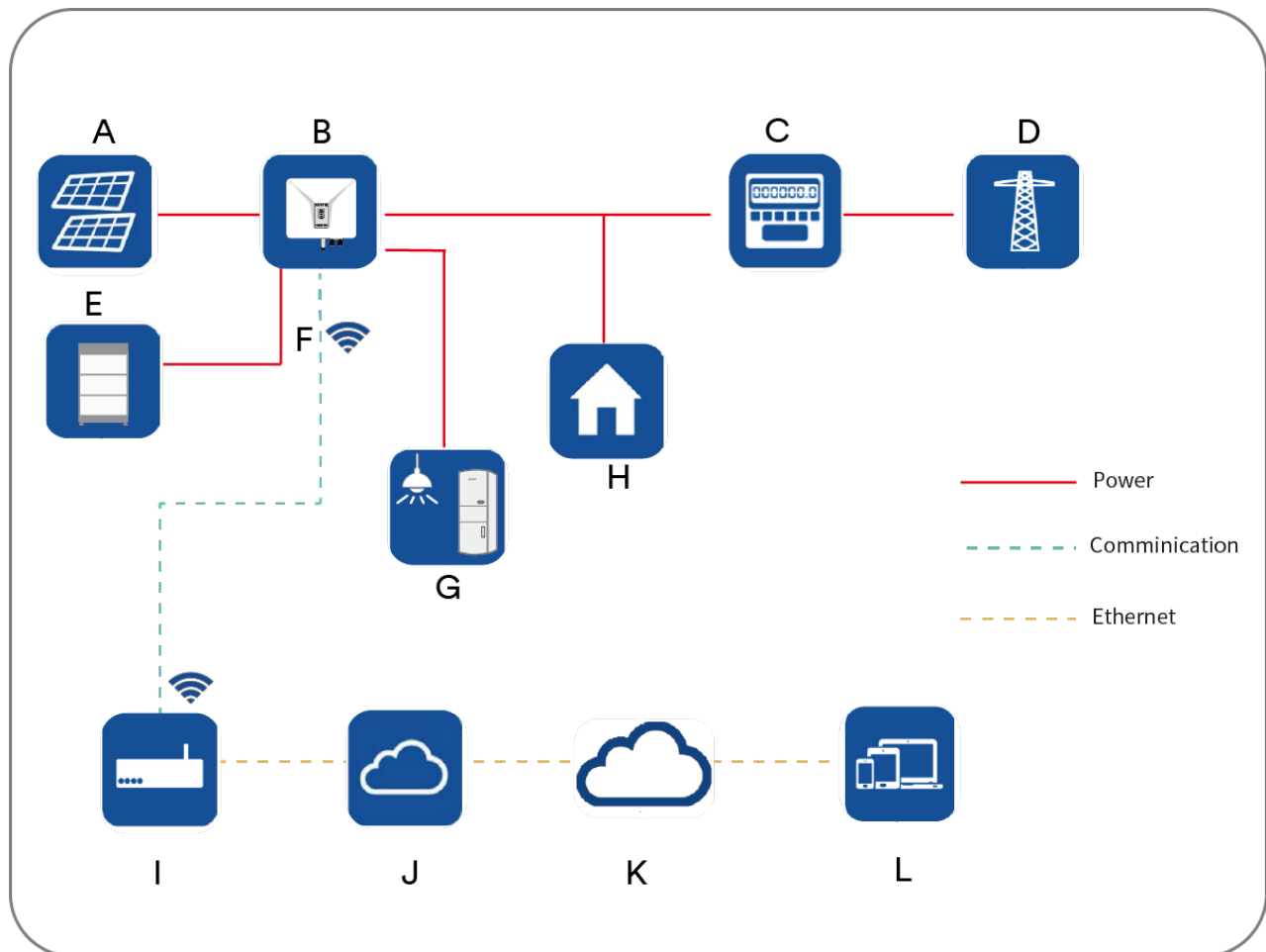
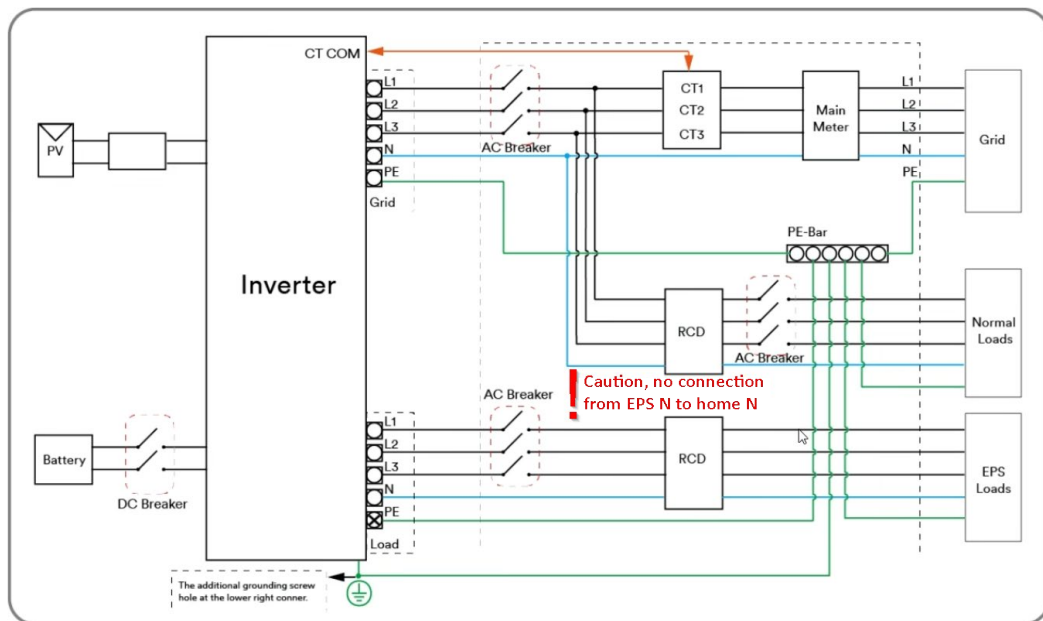

Fig. 2. Diagram of the system.

Item	Key	Definition / information on the connection
A	PV generator	The device supports to connect the monocrystalline silicon, polycrystalline silicon, and thin-film without grounding.
B	Inverter	Blueplanet hybrid 6.0-12.0 NH3 M2 and 8.0-12.0 NH3 M3 series devices have an EPS port.
C	Smart meter	The smart meter is the central device responsible for energy management.
D	Utility grid	The device can connect to TN and TT grounding system grid.
E	Battery system	The device must only be operated in connection with an intrinsically safe lithium-ion battery system approved by KACO.
F	Communication device (Connect-NH)	The Communication device (Connect-NH) supports Ethernet communication and WLAN communication. It is not recommended to use both communication methods at the same time.
G	EPS Load (Back-up)	The back-up load directly connected to the EPS port of the inverter. The back-up load can be power supplied by the inverter after the utility grid is failure.
H	Normally Load	The normally load directly connected to utility grid. The normally load will be power off after the utility grid is failure.

I	Router	The device can connect to router through Wi-Fi signal or Ethernet cable.
J	Internet	The monitor information can transfer to Cloud Server through Internet.
K	Cloud server	The monitor information is stored at cloud server.
L	KACO blueplanet Smart Cloud	The APP can be installed on the smart phone and then review the monitor information. The monitor information also can be review on the computer.

The system diagram of this device as follow:



The wiring system of the basic application is an example for grid systems without special requirement:

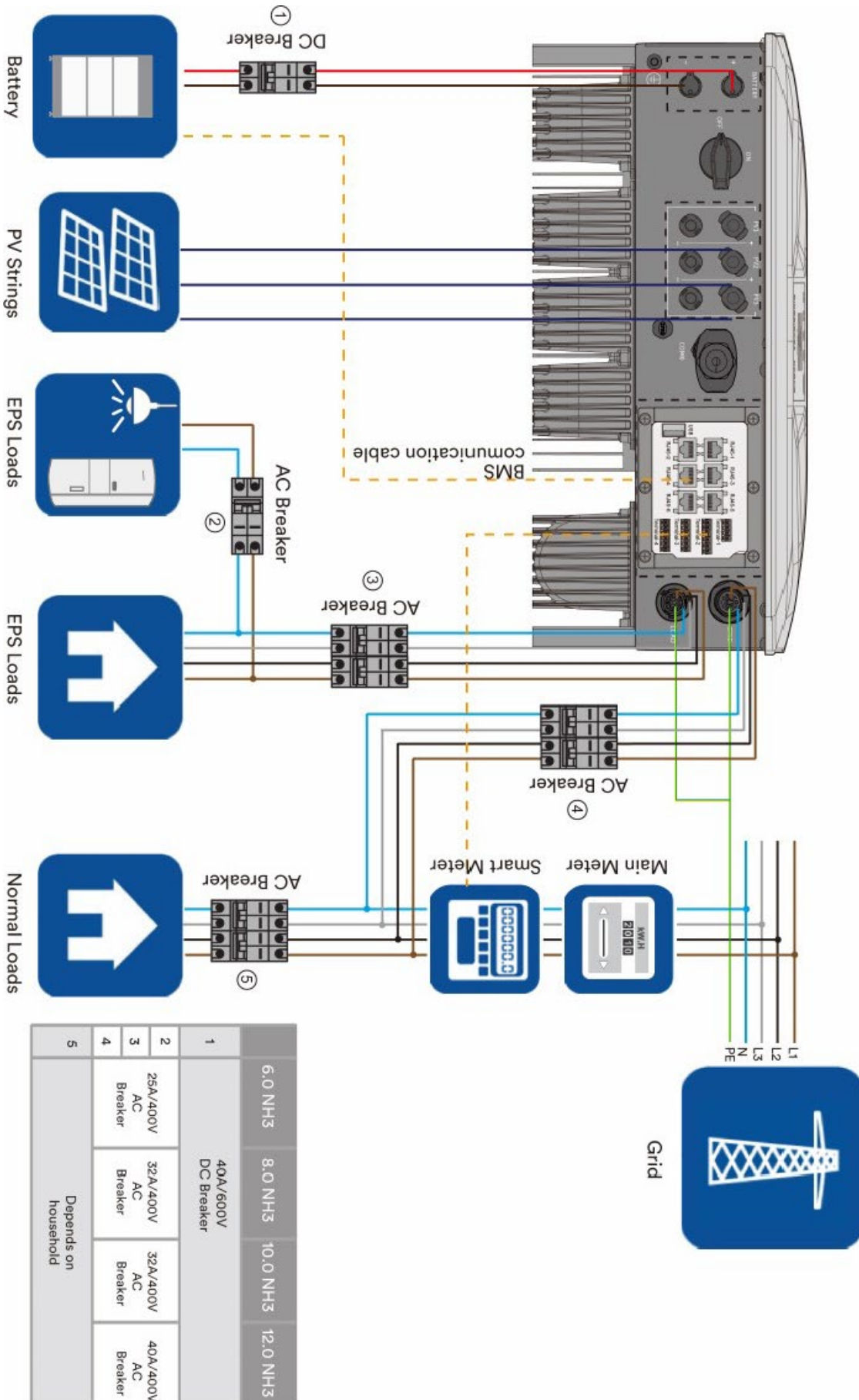

3.2 Integration in a parallel system

A maximum of 16 hybrid inverters of the same type can be operated as a parallel system. The communication device must only be connected to the master device.

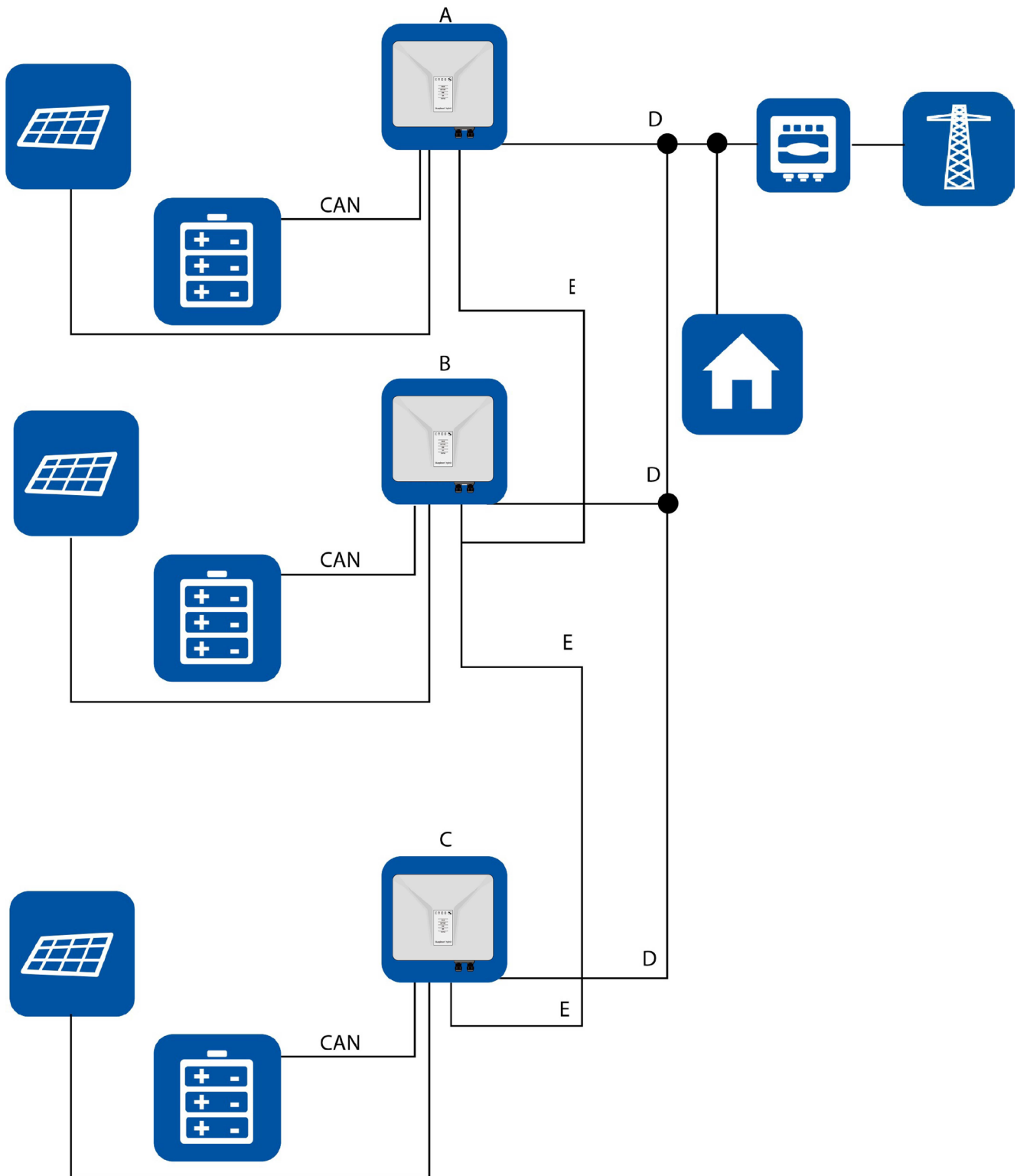
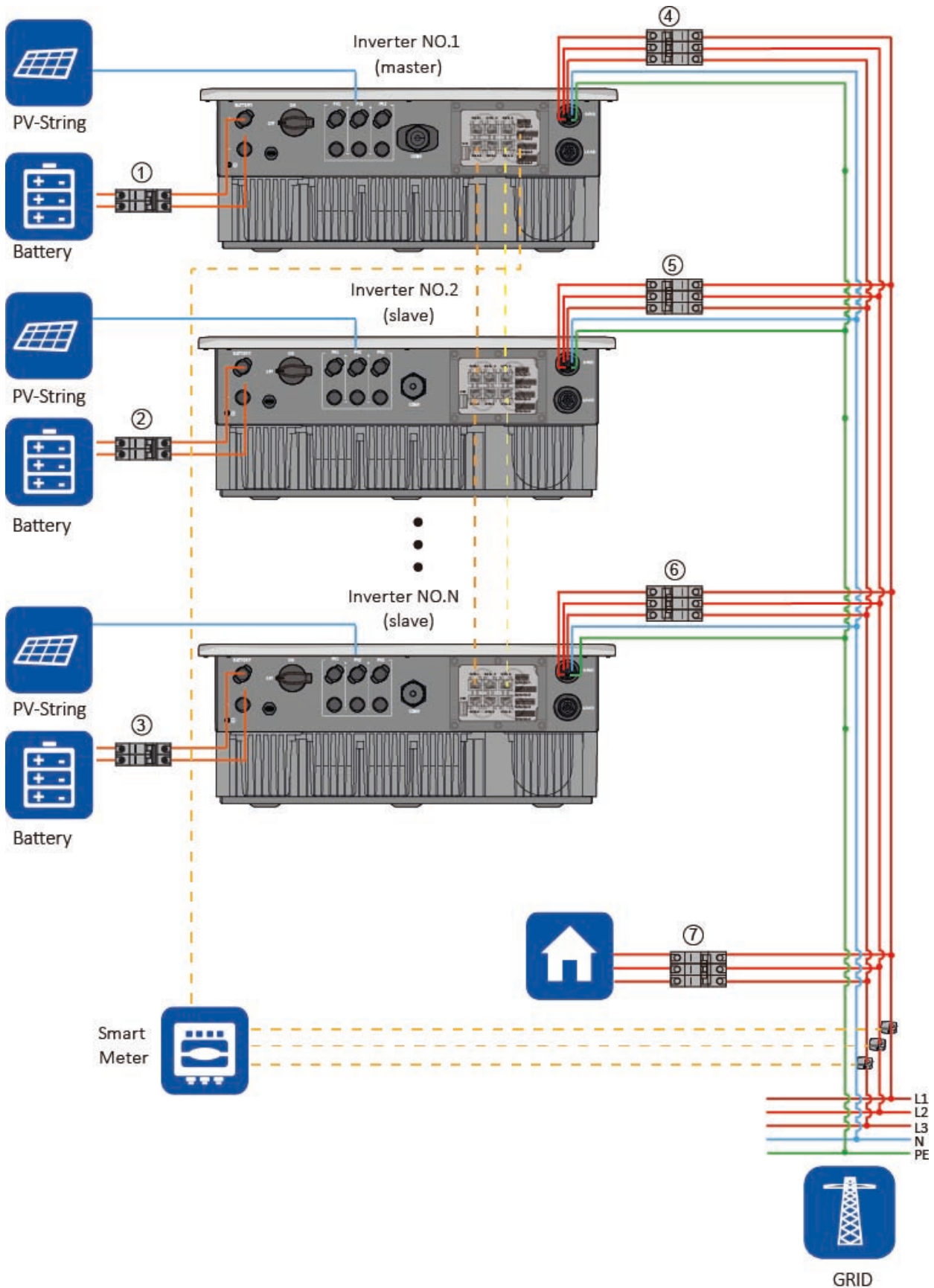

Fig. 3. Diagram of the parallel system

Item	Key	Definition / information on the connection
A	Master	Hybrid-Inverter – configured as master device
B	Slave	Hybrid-Inverter – configured as slave device
C	Slave	Hybrid-Inverter – configured as slave device with terminating resistor
D	Grid	Connection to grid
E	RS485	Communication in parallel mode



Item	Key	Definition / Fuse size
① ② ③	FUSE	DC breaker for battery 80 A
④ ⑤ ⑥	FUSE	AC breaker for grid port 100 A
⑦	FUSE	Depended on household load

3.3 Integrated energy management

The energy management mode depends on PV energy and user's preference. There are four energy management mode can be chosen.

3.3.1 Self-Consumption mode

The photovoltaic energy is preferentially used by local load to improve the self-consumption rate and self-sufficiency rate.

The energy management during daytime:

Case 1: PV power generation is lower than the load power consumption, and the energy of the battery is not available.

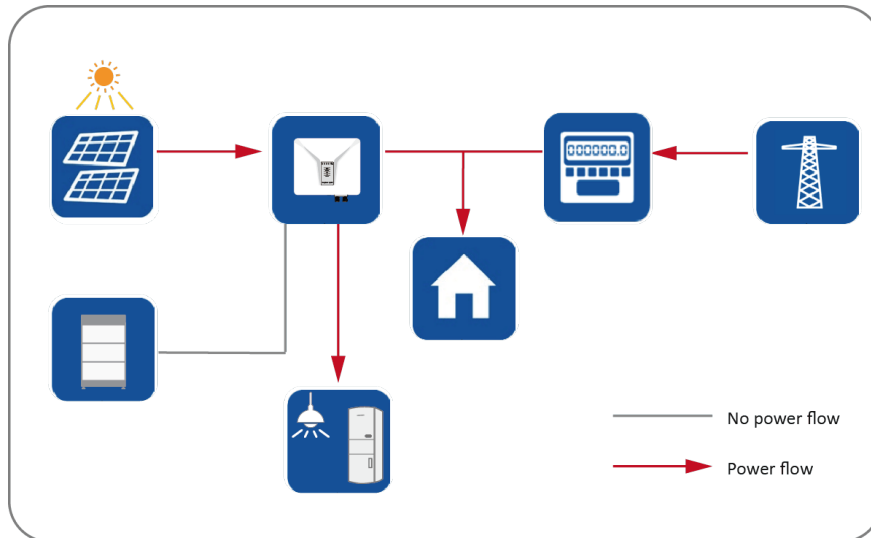

Case 2: PV power generation is lower than the load power consumption, and the energy of the battery is available.

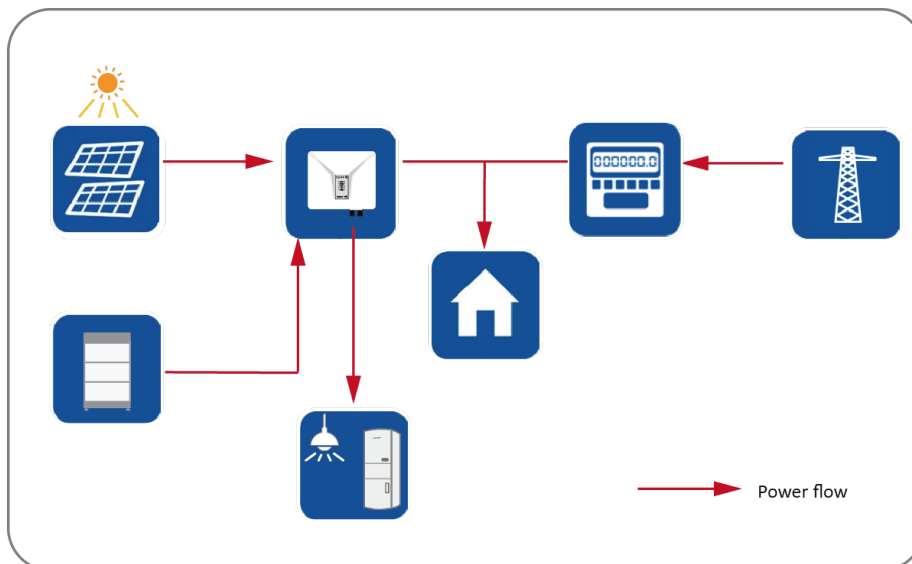

Case 3: PV power generation is larger than the load power consumption.

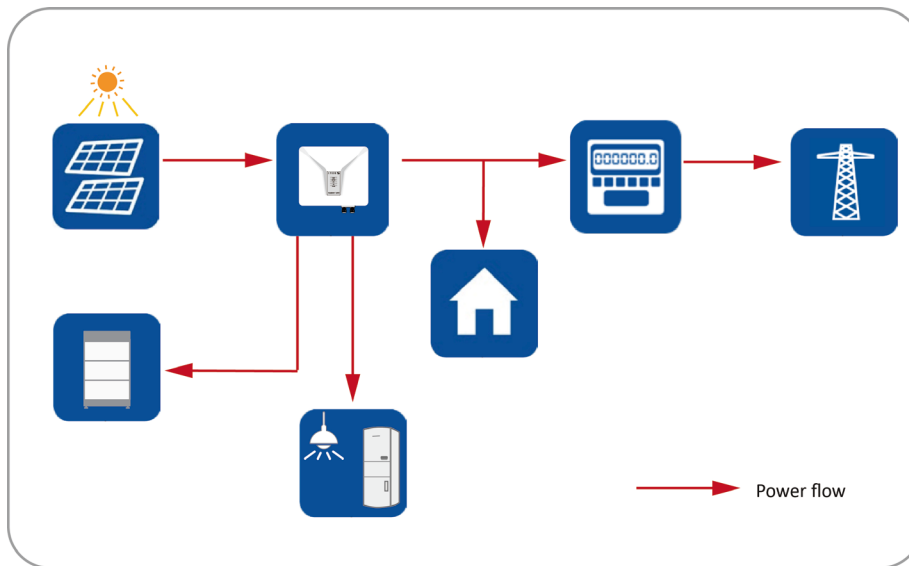

The energy management during night:

Case 1: The energy of the battery is available.

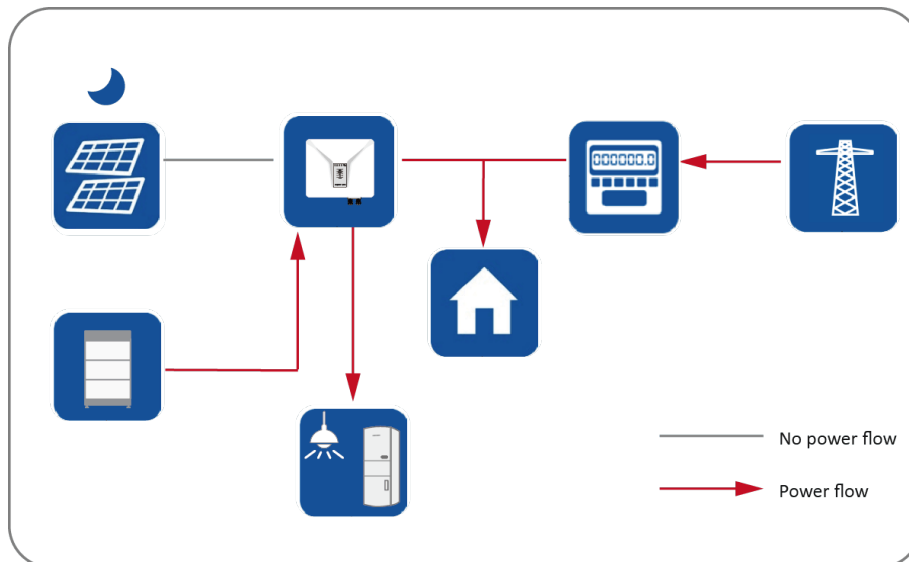

Case 2: The energy of the battery is not available.

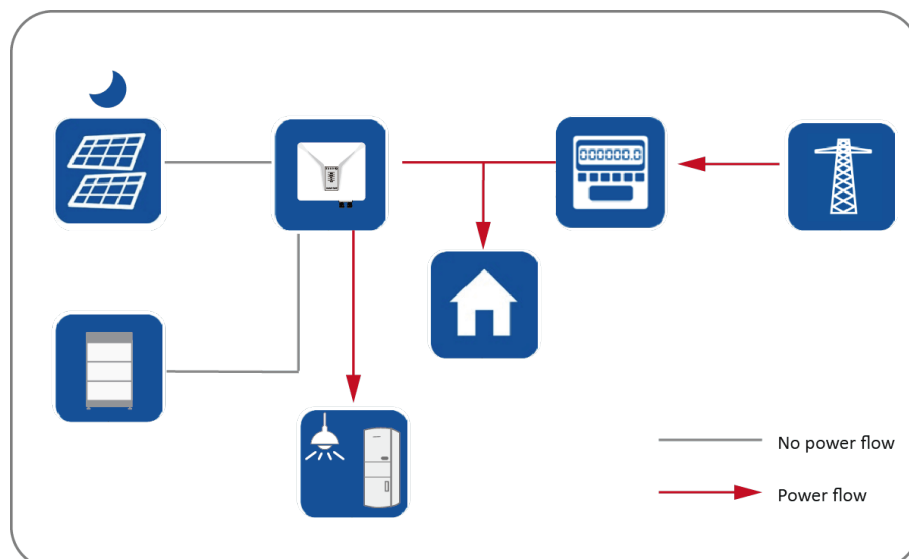

3.3.2 Reserve energy mode

The battery is a back-up energy storage device. The battery always charged by PV power if it is not full charged. The battery discharge only when the utility grid loss.

Case 1: The energy of the battery is not full charged.

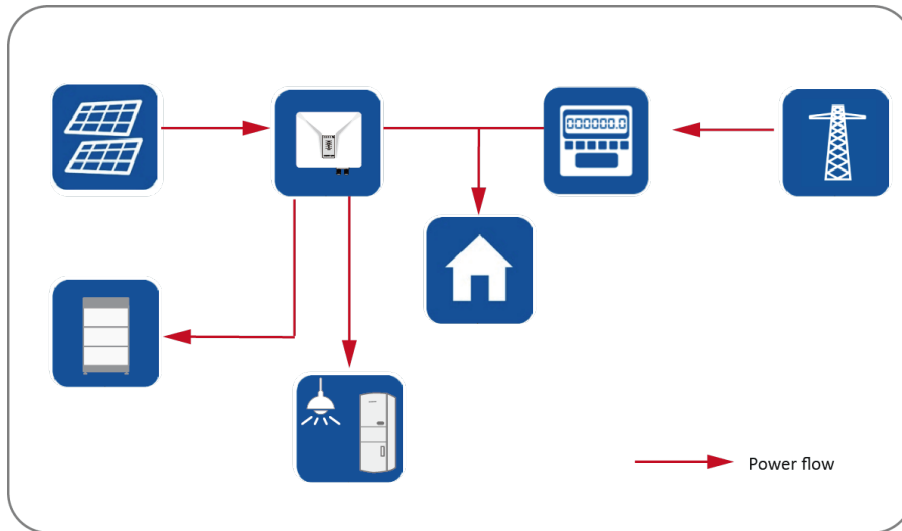

Case 2: The energy of the battery is full charged, even at night.

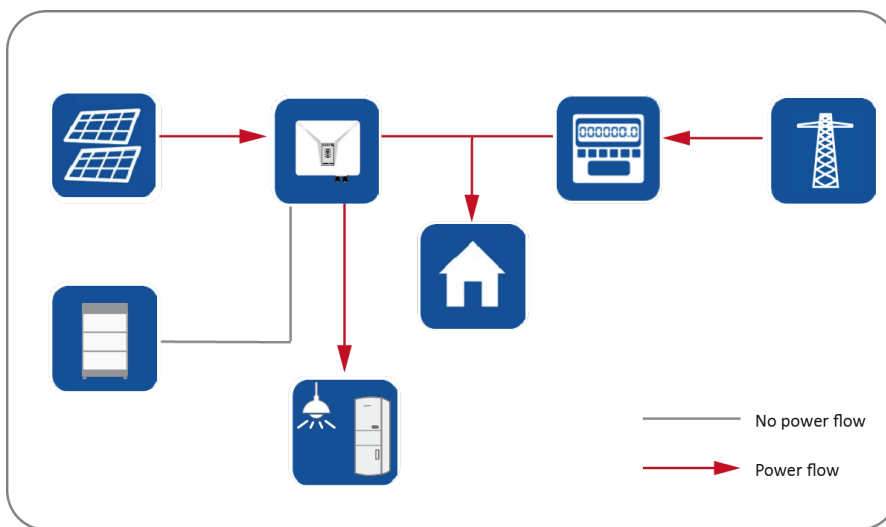

Case 3: The battery discharge when the utility grid loss.

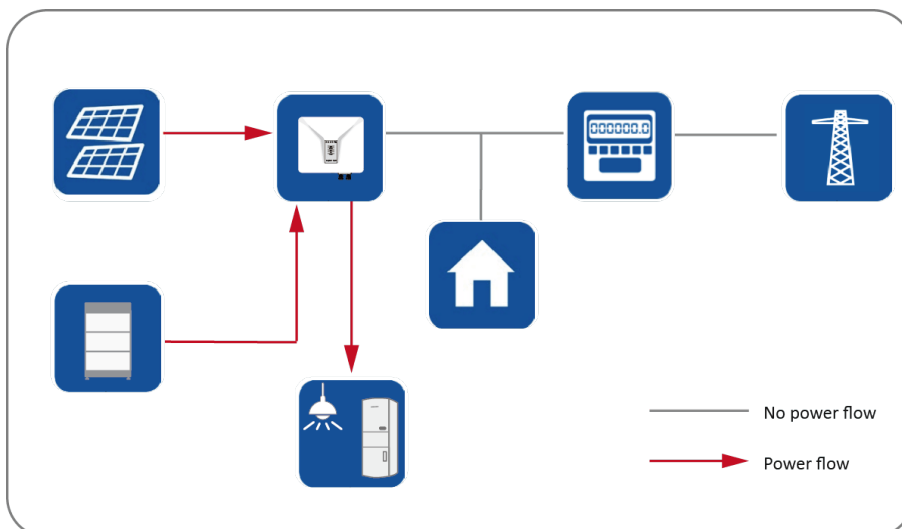

3.3.3 Custom mode

In user-defined mode, customers can set their own charging and discharging time periods, and the charging and discharging power can be set by themselves in the APP.

3.3.4 Off-grid mode

If the power grid is too weak and the inverter operating unstably, it is recommended that the customer switch to off grid mode to achieve stable power supply.

3.4 Compatible accessories

3.4.1 Released battery storage units

The following battery storage units are included in the current version 7.x of the device software.

Vendor	Type	Capacity (approx.)
BYD	Battery-Box Premium HVS	5.1 until 10.2 kWh
BYD	Battery-Box Premium HVM	8.3 until 11.0 kWh
Pylontech	Force H1 / H2 / H3	10.65 until 24.86kWh
Dyness	Tower	6,74 until 21,31 kWh

Please refer to the data sheet in the download section of the KACO new energy website for information on the approved battery.

General information on connecting the battery storage unit to the device. Please consult the manual of the battery manufacturer.

4 Technical data

4.1 Electrical data

KACO blueplanet hybrid	6.0 NH3 M2 B1 WM OD IIG0	8.0 NH3 M3 B1 WM OD IIG0	10.0 NH3 M3 B1 WM OD IIG0	12.0 NH3 M3 B1 WM OD IIG0
PV Input				
Max Recommended PV Array Power	9000 W	12000 W	15000 W	18000 W
Max PV Voltage	1100 V			
Operating Voltage Range / Start Voltage	150 V - 950 V / 200 V	200 V-950 V / 200 V	200 V-950 V / 200 V	200 V-950 V / 200 V
Mpp Voltage Range at Pnom	290 V-850 V	250 V-850 V	320 V-850 V	380 V-850 V
Nominal PV Voltage	630 V			
Max PV Current (Isc) ²	30 A / 30 A		24 A / 24 A / 24 A	
Nominal PV Current (Inom)	20 A / 20 A		16 A / 16 A / 16 A	
Number of strings	2 / PV1:1; PV2:1		3 / PV1:1; PV2:1, PV3:1	
Number of MPP controls	2		3	
Max. input source feedback current	0 A			
Polarity safeguard	yes			
DC overvoltage protection	Type II			
KACO blueplanet hybrid	6.0 NH3 M2 B1 WM OD IIG0	8.0 NH3 M3 B1 WM OD IIG0	10.0 NH3 M3 B1 WM OD IIG0	12.0 NH3 M3 B1 WM OD IIG0
Battery Port				
Voltage Range	120 V – 600 V			
Max Charge / Max Discharge Current	30 A / 30 A			
Max Charge / Max Discharge Power	6000 W / 6000 W	8000 W / 8000 W	10000 W / 10000 W	12000 W / 12000 W
Battery Type	Lithium-ion (LiFePO4)			
KACO blueplanet hybrid	6.0 NH3 M2 B1 WM OD IIG0	8.0 NH3 M3 B1 WM OD IIG0	10.0 NH3 M3 B1 WM OD IIG0	12.0 NH3 M3 B1 WM OD IIG0
Grid Port				
Nominal Grid Voltage	220V / 380V [3/N/PE], 230V / 400V [3/N/PE], 240V / 415V [3/N/PE]			
Grid Voltage Range	160 V - 300 V (Phase to Neutral) 277 V - 520 V (Phase to Phase)			
Nominal Grid Frequency	50 Hz / 60 Hz			
Frequency Range	45 Hz – 65 Hz			
Max Grid Output Power	6000 VA	8000 VA	10000 VA	12000 VA
Max Grid Output Current	9.6 A	12.8 A	16.0 A	19.2 A
Max Grid Input Power	22000 VA	22000 VA	22000 VA	22000 VA
Max Grid Input Current	32.0 A	32.0 A	32.0 A	32.0 A
Power Factor Range	0.8 _{cap} - 0.8 _{ind}			
Harmonics THD	< 3%			
Contribution to peak short-circuit current ip	60 A	60 A	60 A	60 A
Initial short-circuit alternating current (Ik" first single period effective value)	9.6 A	12.8 A	16.0 A	19.2 A
Short-circuit current continuous (Ik. max output fault current)	9.6 A	12.8 A	16.0 A	19.2 A
Inrush current	<20 % of the rated AC current for a maximum of 20 ms			
Number of feed-in phases	3			
AC overvoltage protection	Type II			
KACO blueplanet hybrid	6.0 NH3 M2 B1 WM OD IIG0	8.0 NH3 M3 B1 WM OD IIG0	10.0 NH3 M3 B1 WM OD IIG0	12.0 NH3 M3 B1 WM OD IIG0
EPS Port				
Nominal EPS Voltage	220V / 380V [3/N/PE], 230V / 400V [3/N/PE], 240V / 415V [3/N/PE]			
Nominal EPS Frequency	50 Hz / 60 Hz			
Max EPS Output Power (continuous off-grid)	6000 VA	8000 VA	10000 VA	12000 VA
Max EPS Output Power (peak off-grid)	12000 VA	16000 VA	20000 VA	24000 VA

Max EPS Output Power (continuous on-grid)	22000 VA
Max EPS Output Current (continuous on-grid)	32 A
Power Factor Range (off-grid)	0.8 cap – 0.8 ind
Max Switch Time (UPS mode)	< 10 ms
Harmonics THD (off-grid)	2%

¹ The “Max PV Current (I_{sc})” together with the open circuit voltage (U_{OCmax}) defines the characteristic of the connected PV generator. This is the relevant value for string design and represents the absolute maximum limit for inverter protection. The connected PV generator must be designed in such a way that the maximum short-circuit current is less than or equal to the I_{SCmax} of the inverter under all foreseeable conditions. The design must in no case result in a short-circuit current greater than the I_{SCmax} of the inverter.

4.2 General data

KACO blueplanet hybrid	6.0 NH3 M2 B1 WM OD IIG0	8.0 NH3 M3 B1 WM OD IIG0	10.0 NH3 M3 B1 WM OD IIG0	12.0 NH3 M3 B1 WM OD IIG0
Max. efficiency	97.81 %	97,97 %	98,11 %	98,19 %
European efficiency	95.47 %	95,91 %	96,46 %	96,55 %
Max battery to load efficiency	97,48%	97,79%	97,88%	97,85%
Self consumption: Standby	< 10 W			
Feed-in from	60 W			
Transformer unit	no			
Protection class / over voltage category	I / III (AC) II (DC)			
Grid monitoring	Country-specific			
Distribution system	TN-C-System, TN-C-S-System, TN-S-System, TT-System			
Display	LEDs			
Controls	no			
Menu languages	EN, DE			
Interfaces	WLAN / RS485/ APP			
Communication	WLAN, SunSpec Modbus RTU, CAN(BMS)			
Radio technology	WLAN 802.11 b / g / n			
Frequency spectrum	2,412 MHz - 2,472 MHz			
Antenna gain	2 dBi			
Potential-free relay	no			
DC isolator switch for PV side	Yes			
AC isolator switch	no			
Cooling	Natural convection			
Number of fans	1 inside			
Noise emission	30 dB(A)			
HxWxD	545 mm × 530 mm (AC plug included) × 230 mm			
Weight	26,5 kg	28,5 kg		
Certifications	Overview: see website / download area			
Housing material	Aluminium			
Safety	EN 62109-1, EN 62109-2			
Interference immunity/interference emission/grid feedback	EN 61000-6-1, EN 61000-6-2, EN 61000-6-3, EN 61000-6-4, EN 62920 - Class A, EN 55011 - group 1 Class A, EN 61000-3-2, EN 61000-3-3, EN 61000-3-11, EN 61000-3-12			

4.3 Environmental data

KACO blueplanet hybrid	6.0 NH3 M2 B1 WM OD IIG0	8.0 NH3 M3 B1 WM OD IIG0	10.0 NH3 M3 B1 WM OD IIG0	12.0 NH3 M3 B1 WM OD IIG0
Installation height	3000 m			
Installation distance from coast	3000 m			
Ambient temperature	- 25 °C – + 60 °C			
Ambient temperature(storage)	- 40 °C – + 60 °C			
Protection rating (KACO installation location)	IP66			
Humidity range (non-condensing) [%]	100%			
Pollution level inside the enclosure	II			
Pollution level outside the enclosure	III			

4.4 Accessories

KACO blueplanet hybrid	6.0 NH3 M2 B1 WM OD IIG0	8.0 NH3 M3 B1 WM OD IIG0	10.0 NH3 M3 B1 WM OD IIG0	12.0 NH3 M3 B1 WM OD IIG0
Emergency Power box 63 A	Art. No. 3016392			
Current sensors for Smart Meter	Available on request			

5 Transportation and Delivery

Every device leaves our factory in perfect electrical and mechanical condition. Special packaging ensures that the devices are transported safely. The shipping company is responsible for any transport damage that occurs.

5.1 Scope of delivery

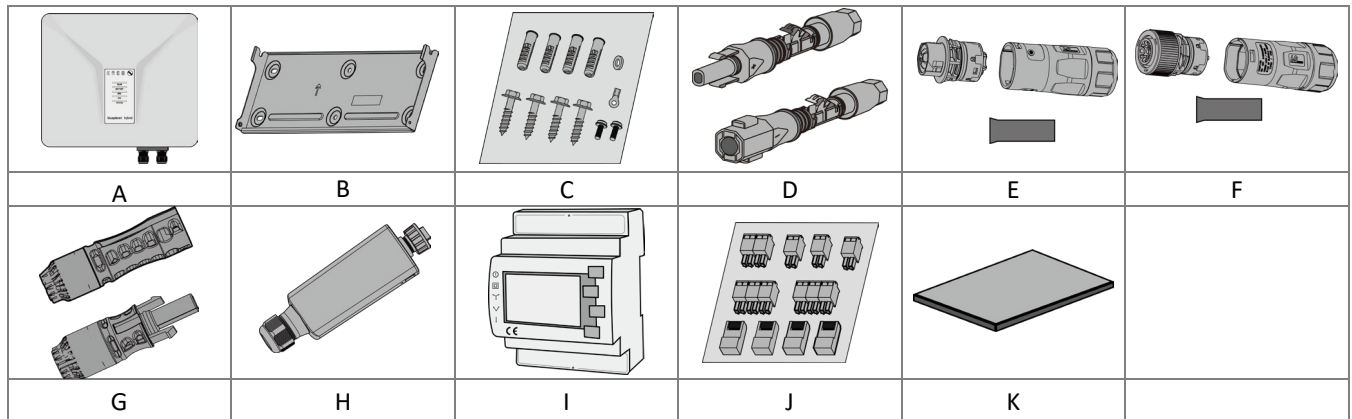

Article	Description	Quantity	Article	Description	Quantity
A	Inverter	1 piece	F	EPS connector	1 piece
B	Wall mounting bracket	1 piece		Terminal	5 pieces
C	Mounting accessory kit: Wall fixings and hex bolts (4×) M5×14 mm screw (2×) Grounding washer (1×) Terminal for OT/DT grounding (1×)	1 set	G	Battery connector	1 pairs
			H	Communication unit (Connect-NH)	1 piece
			I	Smart meter (Eastron SDM630-Modbus V2)	1 piece
D	DC connector (Phoenix Sunclix): (6.0-12.0 NH3 M2) (8.0-12.0 NH3 M3)	2 pairs; 3 pairs	J	Communication terminal package	1 set
E	AC connector	1 piece		K	Documentation

Check the equipment included

- Inspect the device thoroughly.
- Immediately notify the shipping company in case of the following:
 - o Damage to the packaging that indicates that the device may have been damaged.
 - o Obvious damage to the device.
- Send a damage report to the shipping company immediately.
- The damage report must be received by the shipping company in writing within six days following receipt of the device. We will be glad to help you if necessary.

5.2 Transporting the device

CAUTION



Hazard due to impact; risk of breakage to the device!

- › Pack the device securely for transport.
- › Transport the device using the intended carrying handles of the packaging box.
- › Do not expose the device to any shocks.

5.3 Installation tool

The codes given in the table below are used in all usage instructions for assembly/installation/maintenance and disassembly for the tools and tightening torques being used.

Code (s)	Shape of the connector
XW	External hexagon
XT	Torx
XS	Slot
XP	Phillips

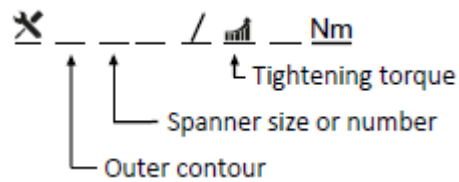

Form pattern

6 Assembly and preparation

6.1 Choosing the installation location

DANGER



Risk of fatal injury due to fire or explosions!

Fire caused by flammable or explosive materials in the vicinity of the device can lead to serious injuries.

- › Do not mount the inverter in an area at risk of explosion or in the vicinity of highly flammable materials.

CAUTION



Property damage due to gases that have an abrasive effect on surfaces when they come into contact with ambient humidity caused by weather conditions.

The device housing can be seriously damaged due to gases in combination with air humidity resulting from weather conditions (e.g. ammonia, sulphur).

- › If the device is exposed to gases, the installation must be carried out at observable locations.
- › Perform regular visual inspections.
- › Immediately remove any moisture from the housing.
- › Ensure adequate ventilation at the installation location.
- › Immediately remove dirt, especially on vents.
- › Failure to follow these warnings may result in damage to the device that is not covered by the manufacturer's warranty.



NOTE

Access by maintenance personnel for service

Any additional costs arising from unfavourable structural or installation conditions will be billed to the customer.

Installation space

- As dry as possible, climate-controlled. The waste heat must be dissipated away from the device
- Unobstructed air circulation
- When installing the device in a control cabinet, provide forced ventilation for sufficient heat dissipation
- Close to the ground, accessible from the front and sides without requiring additional resources
- In outdoor areas, protected on all sides from direct weather exposure and sunlight (thermal heating).
Implementation where necessary via constructional measures, e.g. wind breaks
- Make sure that the inverter is installed out of the reach of children.
- To ensure an optimal operation and a long service life, the temperature of the installation environment of the inverter should be ≤ 40 °C.
- To avoid direct sunlight, rain, snow and puddling on the inverter, we recommend to install the inverter at locations with a protective roof. Do not completely cover the top of the inverter.
- The installation conditions must be able to accommodate the weight and size of the inverter. The inverter is suitable for mounting on a solid wall that is vertical or sloping backwards (max. 20°). It is not recommended to install the inverter on a wall made of plasterboard or similar materials. The inverter may emit audible noises during operation.

Installation surface

- Must have adequate load-bearing capacity
- Must be accessible for installation and maintenance
- Must be made of heat-resistant material (up to 90 °C)
- Must be flame resistant
- Minimum clearances to be observed during installation [see Fig. 9 on Page23].

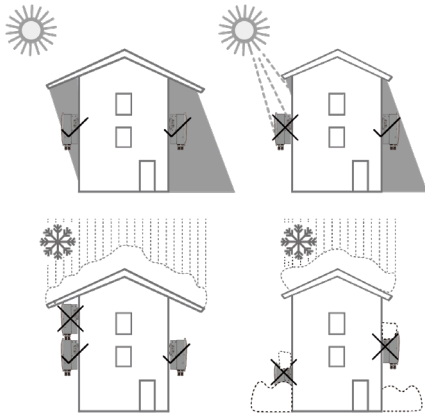

Fig. 4. Device for outdoor installation

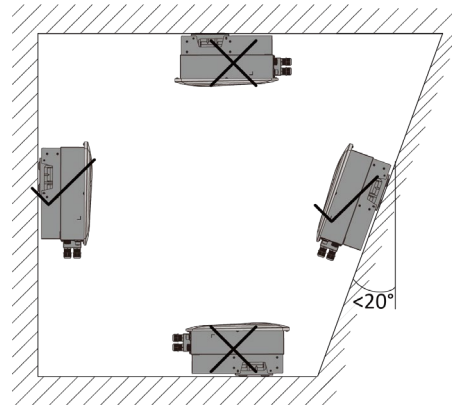

Fig. 5. Permissible installation location

6.2 Unpacking the device



⚠ CAUTION

Risk of injury due to excessive physical strain

Lifting the device, for transport, relocation and assembly can result in injuries (e.g. back injuries).

› Always lift the device using the openings provided

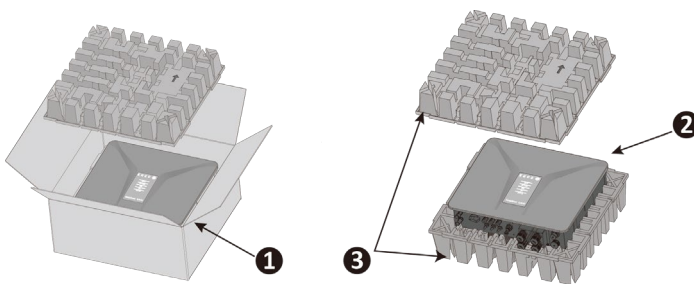

Fig. 6. Unpack the device



Fig. 7. Lift the unit

Key

1	Packaging box	3	Protective packaging
2	Device	4	Lifting position

🔄 The device has been transported to the installation site.

1. Loosen packaging tape from cardboard box.
2. Open the packaging box at the top.
3. Remove installation material and documentation.
4. Pull up top protective packaging to remove.
5. Remove device from the packaging. Grab onto the cover and the edge of the housing when doing so, and lift it out of the packaging.
6. Place the protective packaging back into the packaging box.
7. Lift the device at the intended positions. (see Fig. 7).

» Proceed with the installation of the mount

6.3 Fastening the mount

⚠ CAUTION



Hazard when using unsuitable fixing materials!

If unsuitable fixing materials are used, the device could fall and persons in front of the device may be seriously injured.

- › Use only fixing materials that are suitable for the mounting base. The fastening materials supplied are only suitable for masonry and concrete.
- › Only install the device in an upright position.

NOTE



Power reduction due to heat accumulation!

If the recommended minimum clearances are not observed, the device may go into power regulation mode due to insufficient ventilation and the resulting heat build-up.

- › Observe minimum clearances and provide for sufficient heat dissipation.
- › All objects on the device housing must be removed during operation.
- › Ensure that no foreign bodies prevent heat dissipation following device installation.

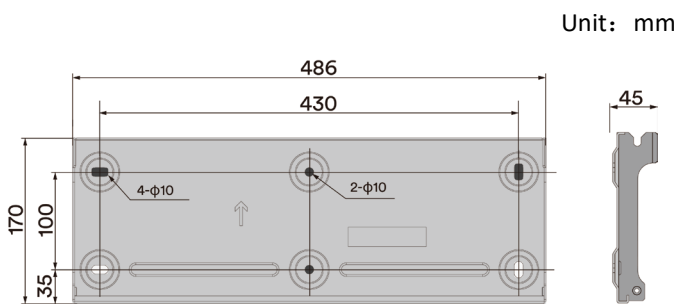

Unit: mm

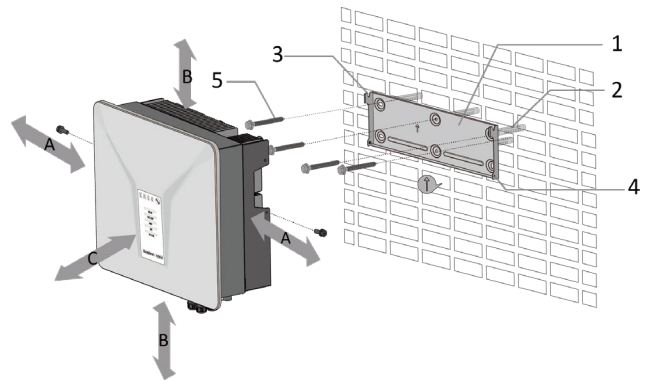

Fig. 8. Drill holes for wall mounting

Fig. 9. Mounting the wall bracket

Key

1 Install the wall holder	5 Screw for mounting (4x)
2 Fastening anchors (4x) [Drill four holes \varnothing 10mm depth 70mm]	A Minimum clearance: 500 mm
3 Mounting ears	B Minimum clearance: 500 mm
4 Screw for securing purposes (2x)	C Minimum clearance: 500 mm

🔄 Cardboard packaging with mount and mounting kit removed from the packaging and opened.

1. Mark the mounting position on the wall surface according to the position of the mount plate by drawing four marks.

NOTE: The arrow must point upwards and be visible when the mount is attached to the wall. Also make sure that the mount is oriented correctly.

2. Mark the positions of the drill holes using the slot in the mount.

NOTE: The minimum clearances between two devices, or the device and the ceiling or floor have must be taken into account.

3. Fix the mount to the wall using suitable mounting fixtures from the mounting kit [XW-5].

NOTE: Make sure that the mount is oriented correctly.

» Proceed with the installation of the device.

6.4 Installing and securing the device



CAUTION

Risk of injury from improper lifting and transport.

If the device is lifted improperly, it can tilt and result in a fall.

- › Always lift the device vertically using the openings provided.
- › Use a climbing aid for the chosen installation height.
- › Wear protective gloves and safety shoes when lifting and lowering the device.

Lifting and installing the device

↻ The mount has been installed.

1 Lift the device using the recesses. Observe the centre of gravity!

2 Fit the device onto the mounting bracket. Check both sides of the heat sink to ensure that it is securely in place. [see Fig. 11].

3 Insert the screw provided into the wall bracket and fasten the device to secure against displacement. [\times P / μ 2.5 Nm] [see Fig. 12].

NOTE: At this point, the screw described above can also be replaced by a special screw as anti-theft protection.

» Device is installed. Proceed with the electrical installation.

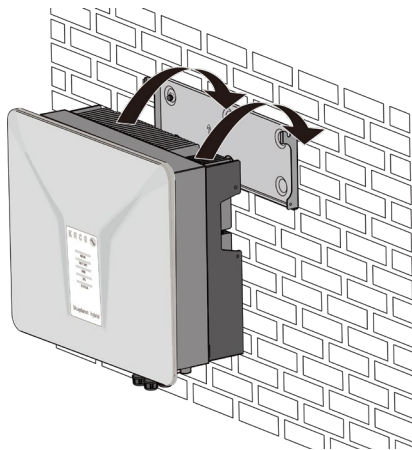

Fig. 10. Mount the inverter to the wall bracket

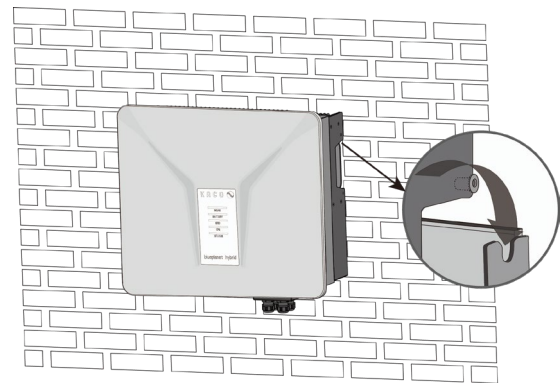

Fig. 11. Check that the device is secure.

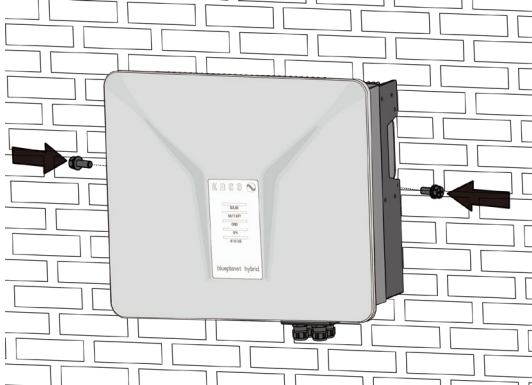

Fig. 12. Secure the inverter

CAUTION

Property damage as a result of condensation

During pre-assembly of the device, moisture can enter the internal space via the DC connectors and the dust-proof screw connections. The resulting condensate can cause damage to the device during installation and start-up.



- Keep the device closed during pre-assembly and do not open the connection area until you perform installation.
- Seal off any plug-in connections and screw fittings using sealing covers.
- Immediately remove any moisture from the housing.

7 Installation

7.1 General information



DANGER

Lethal voltages are still present in the connections and cables of the device even after the device has been switched off and disconnected!

Coming into contact with the lines and/or terminals/busbars in the device can cause serious injury or death.

- › Do not open the device.
- › The device must be mounted in a fixed position before being connected electrically.
- › Comply with all safety regulations and current technical connection specifications of the responsible power supply company.
- › Switch off the grid voltage by turning off the external circuit breakers.
- › Check that all AC and DC cables are completely free of current using a clip-on ammeter.
- › Do not touch the cables and/or terminals/busbars when switching the device on and off.

7.2 Overview of connection area

The connection for the AC supply is located on the housing in the lower right area. The DC input source is connected to the DC plugs and DC sockets on the base plate.

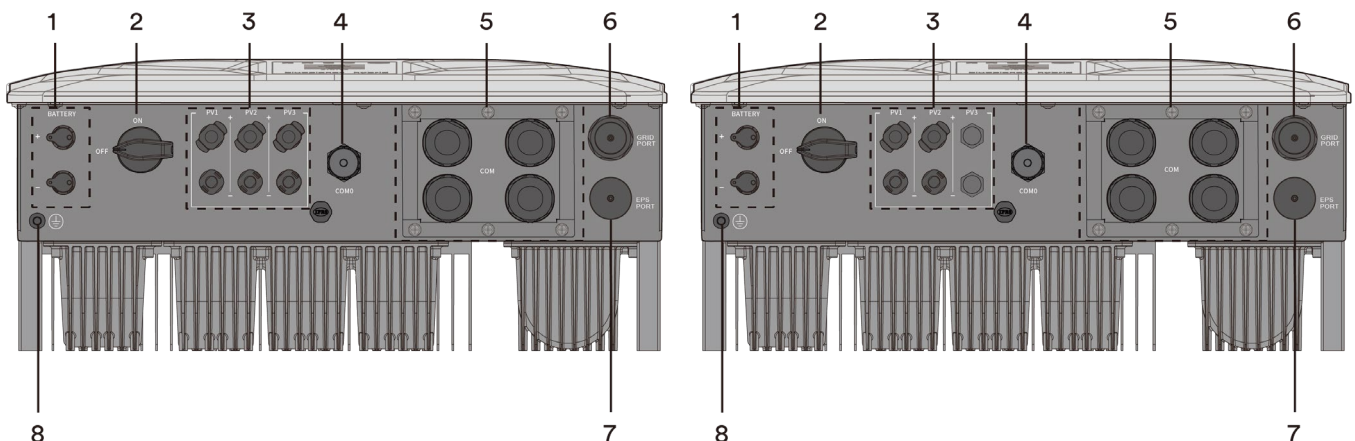

Fig. 13. With 3 MPPT (left) / With 2 MPPT (right)

Legend

1	DC connector for Battery	5	Communication ports
2	DC integrated isolator switch	6	Grid connection socket
3	DC connector for PV generator	7	EPS connection socket
4	Connection for Communication unit (Connect-NH)	8	The position of the equipotential bonding

7.3 Making the electrical connection



NOTE

Select conductor cross-section, safety type and safety value in accordance with the following basic conditions:

Country-specific installation standards; power rating of the device; cable length; type of cable installation; local temperature

7.3.1 Requirement for supply lines and fuse

KACO blueplanet hybrid PV-side	6.0 NH3 M2 B1 WM OD IIG0 + 8.0 NH3- 12.0 NH3 M3 B1 WM OD IIG0
Max. conductor cross-section	6 mm ² (copper)
Min. conductor cross-section	4 mm ² (copper)
Connector type	Adapter Phoenix/PVFT-C2M-HSG Male Adapter Phoenix/PVFT-C2F-HSG Female CABLE: PV-C3F-S 2.5- 6(+)-1386381 PV-C3M-S 2.5- 6(-)-1386384
Recommended cable type	Solar cable
AC-side	
Max. cable diameter	17.5 mm
Min. cable diameter	12.5 mm
Length of cable jacket to be stripped off	40 mm (L1, L2, L3, N), 43 mm (PE)
Max. conductor cross-section	6 mm ² (copper)
Min. conductor cross-section	6 mm ² (copper)
Length of conductor insulation to be stripped off	10 mm
Tightening torque	1.2 ± 0.1 Nm
Connector type	HDC-35i5f1
EPS-side	
Max. cable diameter	17.5 mm
Min. cable diameter	12.5 mm
Length of cable jacket to be stripped off	40 mm (L1, L2, L3, N) 43 mm (PE)
Max. conductor cross-section	6 mm ² (copper)
Min. conductor cross-section	6 mm ² (copper)
Length of conductor insulation to be stripped off	10 mm
Tightening torque	1.2 ± 0.1 Nm
Connector type	HDC-35i5m1
Battery-side	
Max. conductor cross-section	6 mm ²
Min. conductor cross-section	6 mm ²
Connector type	Stäubli (MC4)
Additional ground wire	
Max. conductor cross-section for additional ground conductor connection	6 mm ² (copper)
Min. conductor cross-section for additional ground conductor connection	6 mm ² (copper)
Color of cable	Yellow - green
Interfaces	
RS485 connection type	RJ45, Terminal block
Terminal conductor cross-section	0.25 - 1.5 mm ²
Ethernet cable type	Category 5

7.4 Connecting the device to the power grid



NOTE

If local regulations require the use of a residual-current device, please install a type A residual-current protection device.

7.4.1 Prepare the grid connection



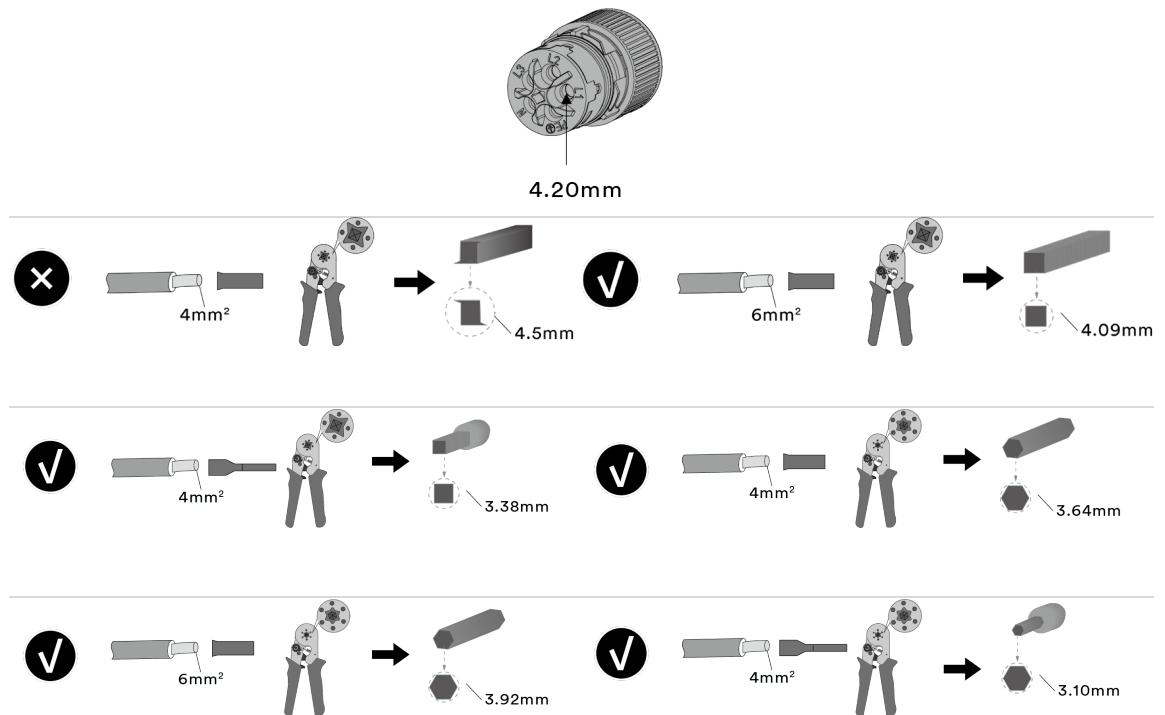

NOTE

Terminals are necessary (not included in the delivery scope) to attach the AC cable to the terminal block. The appropriate crimping tools and requirements are outlined in the table provided.



⌚ Connection area opened.

1. Description of the individual parts of the AC connector [see Fig. 14]
2. Slide the cable fitting over the cable and the housing and seal over the cable.
3. Remove the insulation from the cable.
4. Shorten N and L by 3 mm more than the protective earth and and strip wires N, L, PE by 10 mm.
5. Flexible wires must be fitted with wire sleeves in accordance with DIN 46228.
6. Insert wires into the contacts in accordance with the markings on the contact carrier.
7. Tighten screws on contact carrier. [~~X~~TX_25 /  1.2 Nm]
8. Press contact carriers into the housing with an audible "Click".
8. Fix the housing and tighten the cable screw fitting. [~~X~~W_40 /  2.5±0.5 Nm]

» Make the electrical connections.

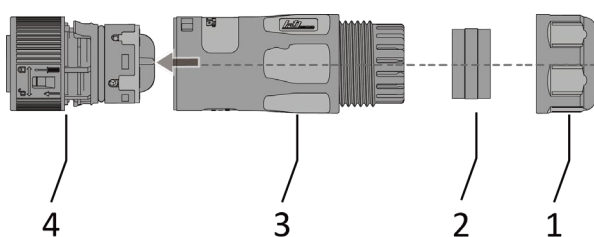

Fig. 14. Grid connection plug

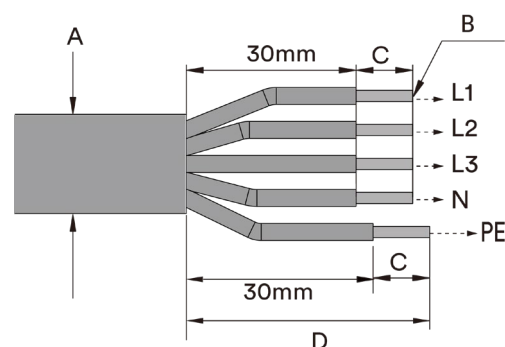

Fig. 15. Strip the insulation from wires

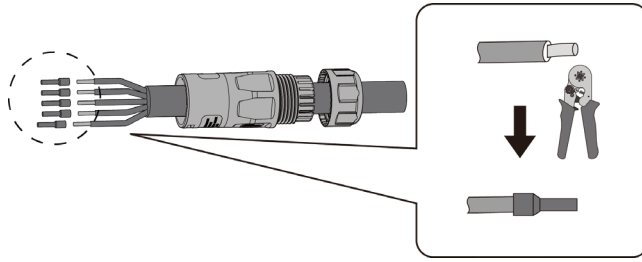

Fig. 16. Crimp wire sleeve to the contact

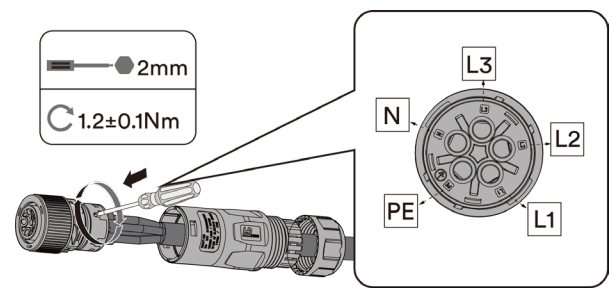

Fig. 17. Placing the wires

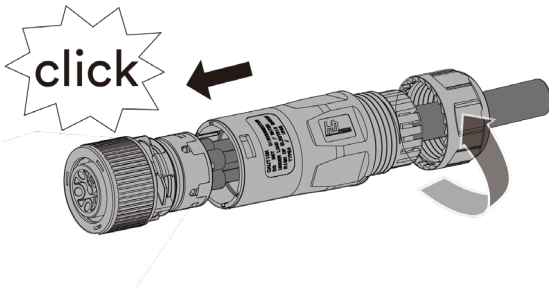

Fig. 18. : Tightening the wires

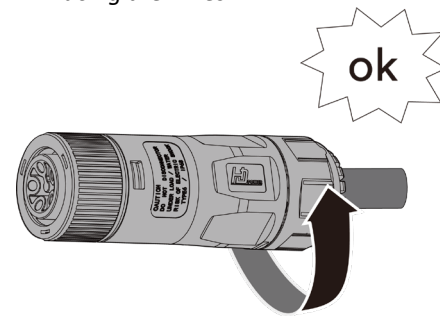

Fig. 19. Tightening the cable fitting

Legend

1	Cable fitting	A	Outer diameter ($\phi 12.5$ to 17.5 mm)
2	Seal	B	Conductor cross-section (4 to 6 mm ²)
3	Housing	C	Length of conductor insulation to be stripped off (approx. 10 mm)
4	Contact carrier	D	Length of cable jacket to be stripped off (approx. 43 mm)

7.4.2 Making the grid connection

⌚ AC connection plug configured correctly.

1. Insert the AC connection plug into the device connector on the device.
⇒ **NOTE: The AC connection is secure when an audible Select is heard.**
2. Lay the cables correctly and in accordance with the following rules:
 - Lay the cables around the device with a minimum clearance of 20 cm
 - Never lay cables over semiconductors (cooling bodies).
 - Excessive bending force may negatively impact the protection rating. Lay the cables with a bending radius of at least 4 times the cable diameter.

» The device is connected to the power grid.

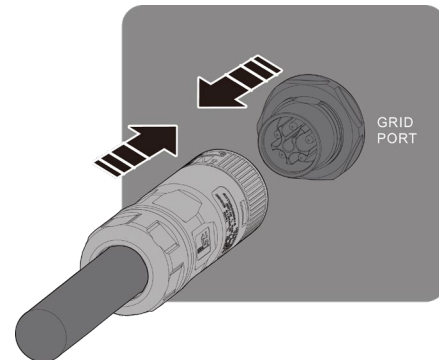

Fig. 20. Connecting the connectors



NOTE

An AC-side disconnection unit must be provided during the final installation stage. This disconnector mechanism must be installed so that it can be accessed at any time without obstruction.



NOTE

If a residual current device (RCD) is necessary due to the installation specification, a Type A RCD device should be used.

For questions regarding the appropriate type, please contact the installer or our KACO new energy customer service.



NOTE

When the line resistance is high, i.e. long cables on the grid side, the voltage at the grid terminals of the device will increase in feed-in mode. If the voltage exceeds the country-specific grid overvoltage limit value, the device switches off.

Ensure that the cable cross-sections are sufficiently large or that the cable lengths are sufficiently short.

7.5 Connecting the EPS to the device

7.5.1 Configuring the EPS



NOTE

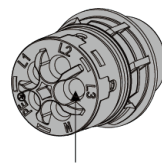

Terminals are necessary (not included in the delivery scope) to attach the EPS cable to the terminal block. The appropriate crimping tools and requirements are outlined in the table provided.

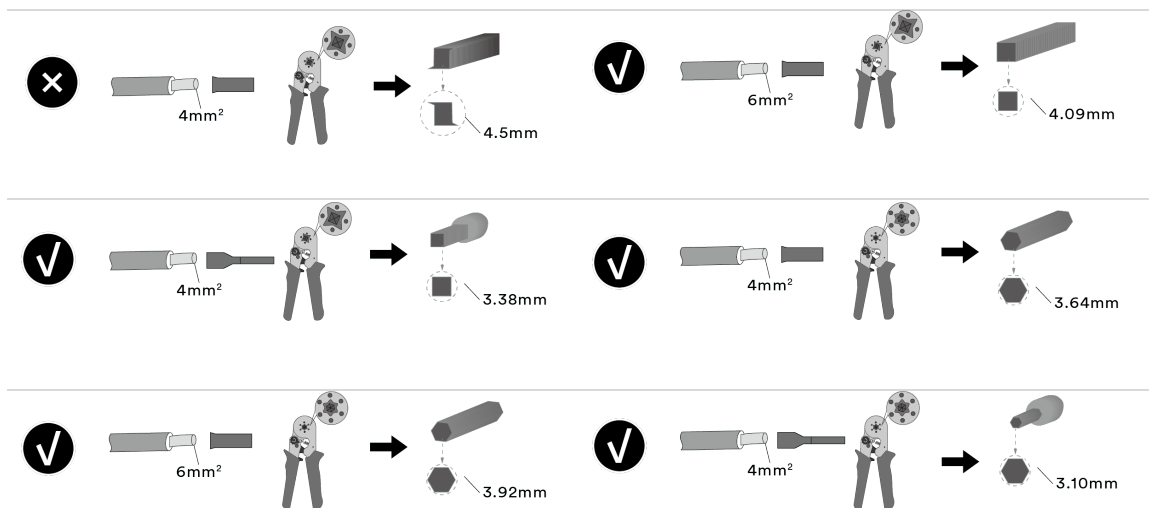

4.20mm



↻ Connection area opened.

1. Description of the individual parts of the EPS connector [see Fig. 21]
 2. Slide the cable fitting over the cable and the housing and seal over the cable.
 3. Remove the insulation from the cable.
 4. Shorten N and L by 3 mm more than the protective earth and strip wires N, L, PE by 10 mm.
 5. Flexible wires must be fitted with wire sleeves in accordance with DIN 46228.
 6. Insert wires into the contacts in accordance with the markings on the contact carrier.
 7. Tighten screws on contact carrier. [~~X~~TX_25 /  1.2 Nm].
 8. Press contact carriers into the housing with an audible "Select".
 9. Fix the housing and tighten the cable screw fitting. [~~X~~W_40 /  2.5±0.5 Nm].
- » Make the electrical connections.

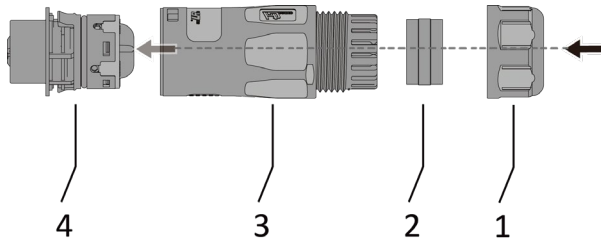

Fig. 21. EPS connection plug

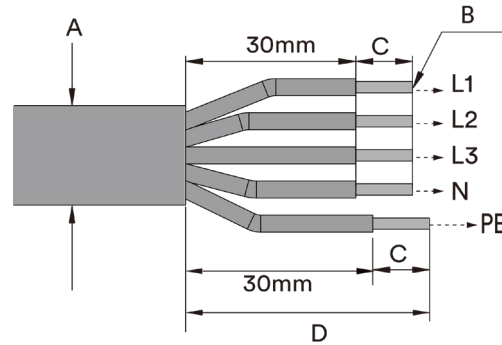

Fig. 22. Strip the insulation from wires

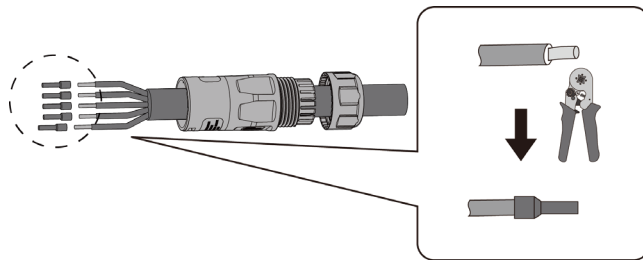

Fig. 23. Crimp wire sleeve to the contact

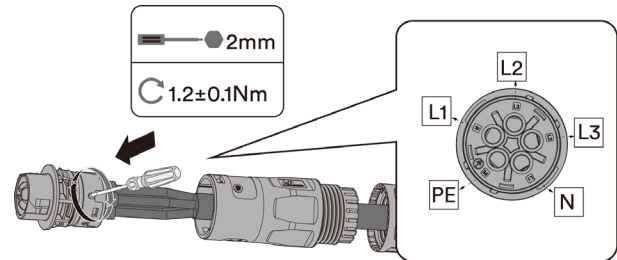

Fig. 24. Placing the wires

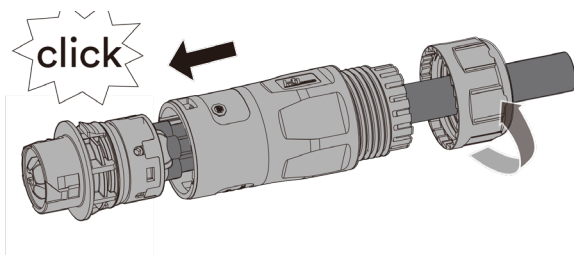

Fig. 25. : Tightening the wires

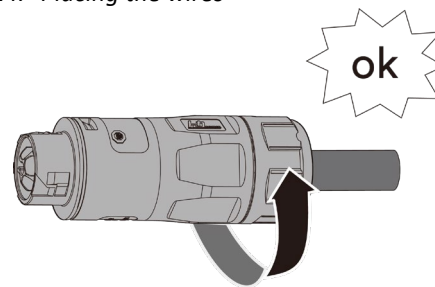

Fig. 26. Tightening the cable fitting

Legend

1	Cable fitting	A	Outer diameter ($\phi 12.5$ to 17.5 mm)
2	Seal	B	Conductor cross-section (4 to 6 mm ²)
3	Housing	C	Length of conductor insulation to be stripped off (approx. 10 mm)
4	Contact carrier	D	Length of cable jacket to be stripped off (approx. 43 mm)

7.5.2 Making the EPS connection

☺ EPS connection plug configured correctly.

1. Insert the EPS connection plug into the device connector on the device.
⇒ **NOTE: The EPS connection is secure when an audible Select is heard.**
 2. Lay the cables correctly and in accordance with the following rules:
 - Lay the cables around the device with a minimum clearance of 20 cm.
 - Never lay cables over semiconductors (cooling bodies).
 - Excessive bending force may negatively impact the protection rating. Lay the cables with a bending radius of at least 4 times the cable diameter.
- » The device is connected to the EPS connection.

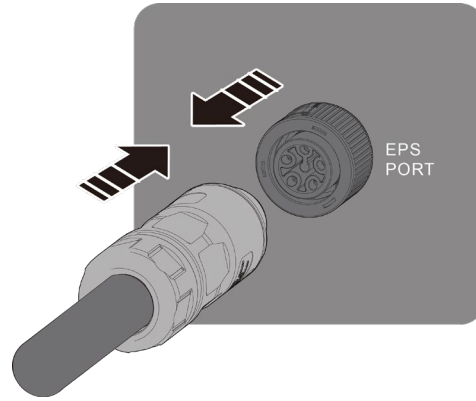

Fig. 27. Connecting the connectors

NOTE



If a residual current circuit breaker is necessary due to the installation specification, a type A residual current circuit breaker must be used.

For questions regarding the appropriate type, please contact the installer or our KACO new energy customer service.

7.5.3 Bypass using EPS-AC-connection

In case of maintenance or repair, the system (hybrid inverter + battery) can be decommissioned using the EPS and AC connection

⌚ Voltage/current free state ensured.

1. Unlock the EPS connector and disconnect it from the device
2. Unlock the AC connector and disconnect it from the device
3. Connect both connectors to each other.

⇒ **NOTE: The plug connection is securely connected when it audibly clicks into place.**

» The system can now be maintained or repaired.

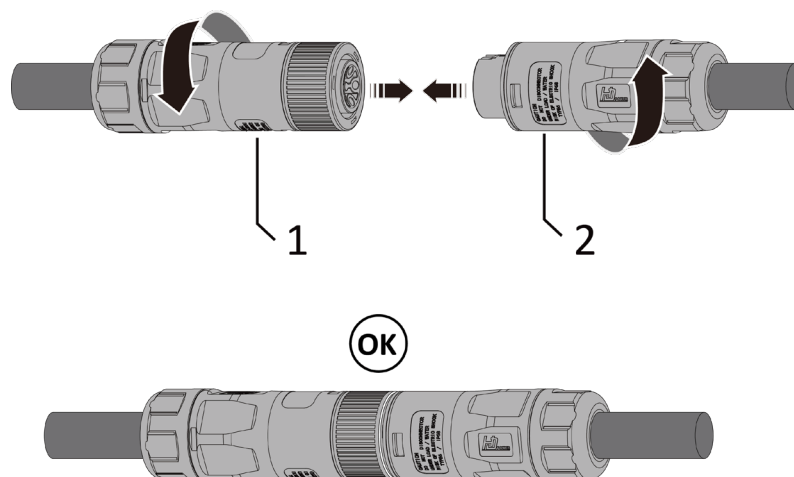

Fig. 28. Bypass connection

Legend

1	GRID-Port	2	EPS-Port
---	-----------	---	----------

7.6 Connecting the PV generator to the device

7.6.1 Configuring the DC connector

DANGER

Risk of fatal injury due to electric shock!

Coming into contact with live connections can cause serious injury or death. When there is sunlight present on the PV generator, there is DC voltage on the open ends of the DC cables.



- › Make sure that PV modules have good insulation against ground.
- › On the coldest day based on statistical records, the max. open-circuit voltage of the PV modules must not exceed the max. input voltage of the inverter.
- › Check the polarity of DC cables.
- › Ensure that the device is completely free of DC voltage.
- › Do not disconnect DC connectors under load.

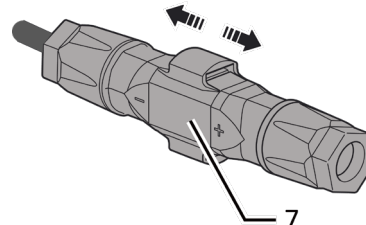
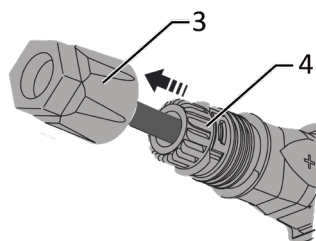
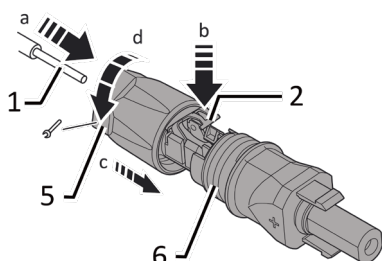



Fig. 29. Insert wires

Fig. 30. Slide insert into sleeve

Fig. 31. Check fastening

Legend

1	Wire for DC connection	5	Cable fitting
2	Spring	6	Contact plug
3	Insert	7	Coupling
4	Sleeve		

 You have completed assembly.

 **NOTE:** Before proceeding with the isolation ensure that you do not cut any individual wires.

1. Insert isolated wires with twisted ends carefully up to the connection.

NOTE: Wire ends must be visible in the spring.

2. Close the spring so that the spring latches and slide insert into sleeve.

3. Secure and tighten the cable fitting [$\times W_{15}$ /1.8 Nm].

4. Join insert with contact plug.

5. Check latch by lightly pulling on the coupling.

› Make the electrical connections



NOTE

The permissible bending radius of at least 4x the cable diameter should be observed during installation.

Excessive bending force may negatively impact the protection rating.

- › All mechanical loads must be absorbed in front of the plug connection.
- › Rigid adaptations are not permitted on DC plug connectors.

7.6.2 Checking the PV generator for a ground fault



DANGER

Risk of fatal injury due to electric shock!

Coming into contact with live connections can cause serious injury or death. When there is sunlight present on the PV generator, there is DC voltage on the open ends of the DC cables.

- › Only touch the PV generator cables on the insulation. Do not touch the exposed ends of the cables.
- › Avoid short circuits.
- › Do not connect any strings with a ground fault to the device.



NOTE

The threshold value above which the insulation monitor reports an error can be set on the mobile device under Other protection settings - Minimum insulation resistance.

Ensure that there is no ground fault

1 Measure the DC voltage between the protective earth (PE) and the positive cable of the PV generator.

2 Measure the DC voltage between the protective earth (PE) and the negative cable of the PV generator.

⇒ If stable voltages can be measured, there is a ground fault in the DC generator or its wiring. The ratio between the measured voltages gives an indication as to the location of this error.

3 Rectify any errors before taking further measurements.

4 Measure the electrical resistance between the protective earth (PE) and the positive cable of the PV generator.

5 Measure the electrical resistance between the protective earth (PE) and the negative cable of the PV generator.

⇒ In addition, ensure that the PV generator has a total insulation resistance of more than 2.0 MOhm, since the device will not feed in if the insulation resistance is too low.

6 Rectify any errors before connecting the DC generator.

7.6.3 Recommended standard connection

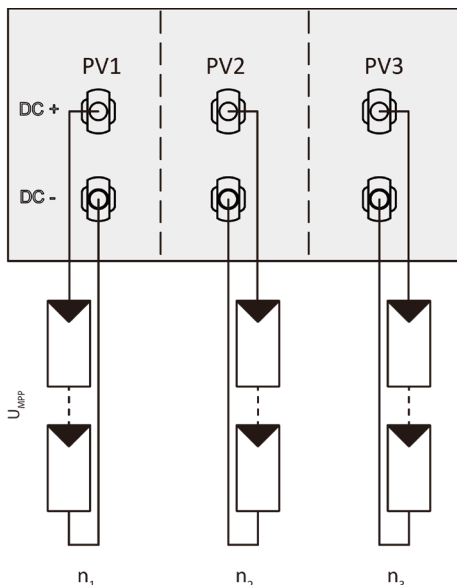

Fig. 32. Assignment of all MPP trackers

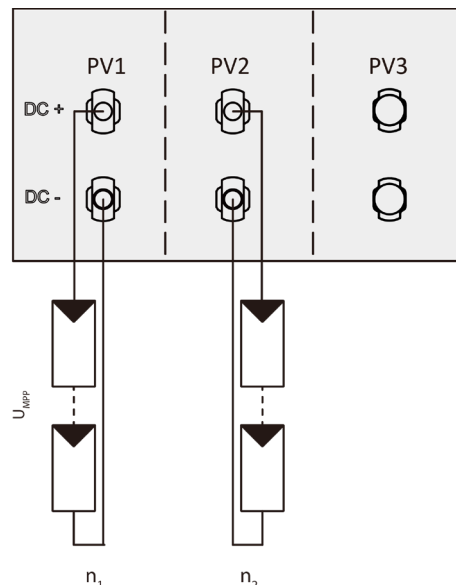

Fig. 33. Assignment of only two MPP trackers

Possible connection of MPP trackers PV1, PV2 and PV3

Two DC strings for each MPP tracker

The MPP voltages of the two DC strings can be different. They are supplied by separate, independently operating MPP trackers (MPP trackers PV1, PV2 and PV3).

Two DC strings for two MPP tracker

If one of the MPP trackers is not used, only the unused DC connectors need to be closed. It is irrelevant whether PV1+PV2 or PV2+PV3 is used.

Number of modules per string:

P_{max} : per string $< 0.6 \cdot \text{max. recommended PV generator power}$

MPP tracker A+B+C together < max. recommended PV generator power

P_{max} : per string < 0.6 * max. recommended PV generator power on the MPP tracker used < max. power per MPP tracker

I_{max} : per tracker < max. rated current (DC)

The input current from Chapter 4.1 on page 17 is different for each MPP tracker and must not be exceeded. Therefore, pay close attention to whether this value applies to PV1, PV2 or PV3.

7.6.4 Designing the PV generator

CAUTION



Damage to components due to faulty configuration!

In the expected temperature range of the PV generator the values for the no-load-voltage and the short circuit current must never exceed the values for U_{dcmax} and I_{scmax} in accordance with the technical data.

- › Observe limit values in accordance with the technical data.

NOTE



Type and configuration of the PV modules.

Connected PV modules must be dimensioned for the DC system voltage in accordance with IEC 61730 Class A, but at least for the value of the AC grid voltage.

NOTE



Dimensioning the PV generator.

The device is designed with a reserve of DC short-circuit current resistance. This allows for oversizing of the connected PV generator. The absolute limit for the PV generator is the value of the max. short-circuit current ($I_{sc\ max}$) and the max. no-load voltage ($U_{oc\ max}$).

7.6.5 PV generator

DANGER



Risk of fatal injury due to electric shock!

Coming into contact with live connections can cause serious injury or death. When there is sunlight present on the PV generator, there is DC voltage on the open ends of the DC cables.

- › Only touch the PV generator cables on the insulation. Do not touch the exposed ends of the cables.
- › Avoid short circuits.
- › Do not connect any strings with a ground fault to the device.

CAUTION



Damage to the PV generator in case of faulty configuration of the DC connector

Incorrect configuration of the DC connector (polarity +/-) leads to device damage in the DC connection if it is connected permanently.

- › Please check polarity (+/-) of the DC connector before connecting the PV generator.
- › Before using the solar modules, check the vendor's calculated voltage values against those actually measured. The DC voltage of the PV system must not exceed the maximum no-load voltage at any time.

Connecting the PV generator

⌚ The DC plug connector has to be configured and PV generator checked to ensure there is no ground fault.

NOTE: Note the different current-carrying capacity of PV1, PV2 and PV3 depending on the power class of the device. See technical data – Chapter 4.1 on page 17 PV1 = (1); PV2 = (2); PV3 = (3).

1 Connect the DC plug connectors to the DC positive and DC negative connectors in pairs.

» The device is connected to the PV generator.

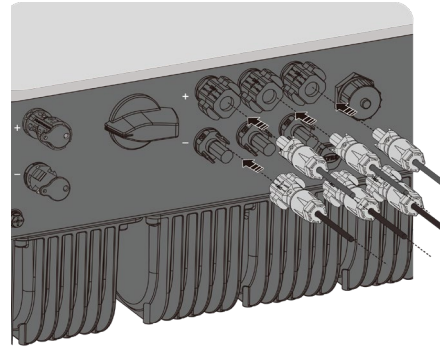

Fig. 34. Current-carrying capacity and plug in PV connector

Closing the unused DC connectors

⌚ All existing strings are connected to the device.

NOTE: Meet the requirements of protection class IP65 by closing the unused plug connectors with the enclosed protective caps.

1 Press down the clamping bracket and push the forcing nut up to the thread. Insert the sealing plug into the DC plug connector and tighten the forcing nut.

2 Finally, insert DC plug connectors with sealing plugs into the corresponding DC input terminals on the device.

» Unused DC plug connectors are closed.

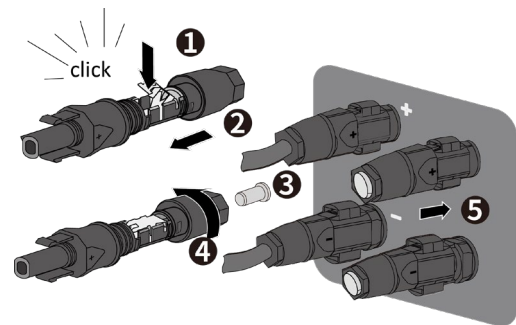

Fig. 35. Insert DC plug connectors and close unused connectors

7.7 Connecting the battery storage unit

7.7.1 Configuring the battery storage unit

DANGER



Risk of fatal injury due to electric shock, fire or explosions!

Serious injury or death due to the use of unsuitable, not intrinsically safe or defective battery storage units!

- › Check the certification and release of the battery storage unit.
- › Check the battery storage unit for obvious damage.
- › Observe the manual of the battery manufacturer.

CAUTION



Damage to the battery storage unit or the device due to the use of incorrect batteries

Only released battery storage units may be connected. Please refer to our manual of the battery manufacturer.

NOTE

Damage to the inverter due to the wire of battery grounded.

The hybrid inverter is a transformerless type. If the positive wire or negative wire of the battery connected to the ground, the inverter will be damaged.

- › Make sure the battery's positive and negative cables are well insulated from ground.

NOTE

Check the grounding of the battery storage unit!

Check that the battery storage unit is properly grounded according to the manufacturer's instructions. It must be connected to the same ground potential as the device itself.

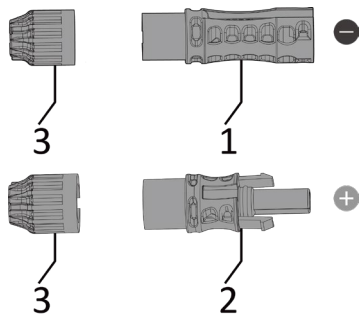

Fig. 36. Battery connection plug

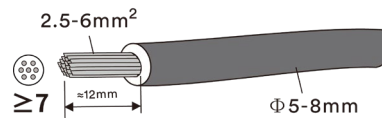

Fig. 37. Strip the insulation from wires

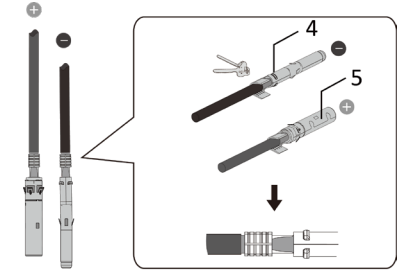

Fig. 38. Assemble the cable ends with the crimping pliers.

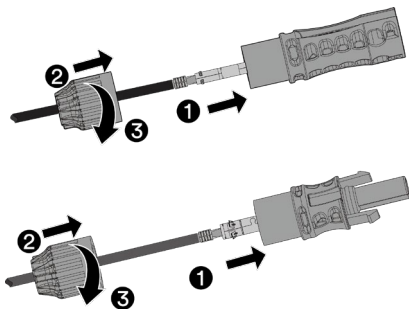

Fig. 39. Tightening the wires

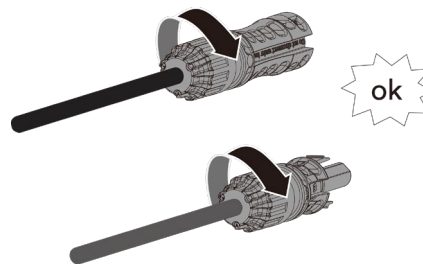

Fig. 40. Tightening the cable fitting

Legend

1	Contact plug-	4	Negative crimp contact
2	Contact plug+	5	Positive crimp contact
3	Cable fitting		

🔄 You have completed assembly.

🔄 **NOTE: Before proceeding with the isolation ensure that you do not cut any individual wires.**

1. Description of the individual parts of the battery connector [see Fig. 36]
 2. Slide the cable fitting over the cable and the housing.
 3. Strip the cable by 8-10 mm.
 4. Assemble the cable ends with the crimping pliers.
 5. Lead the cable through cable gland, and insert into the insulator until it snaps into place. Gently pull the cable backward to ensure firm connection. Tighten the cable gland and the insulator. [🔊 2.5-3.0 Nm]
- » Make the electrical connections

7.7.2 Making the battery storage unit connection



⚠️ CAUTION

An incorrect connection of the battery can damage the device.

Do not confuse the battery input with the inputs of the PV generator. Incorrect connection can damage the PV input or even the battery input

- › The battery input can be damaged by the high PV voltage.
- › The PV input can be damaged by the high battery current.

- ↻ The connectors of the battery storage unit are configured.
- ↻ Device is switched off.

1. Insert the Battery connection plug into the device connector on the device.
 - ⇒ **NOTE: The inverter will not function properly if any PV polarity is reversed.**
2. Lay the cables correctly and in accordance with the following rules:
 - Lay the cables around the device with a minimum clearance of 20 cm.
 - Never lay cables over semiconductors (cooling bodies).
 - Excessive bending force may negatively impact the protection rating. Lay the cables with a bending radius of at least 4 times the cable diameter.

» The device is connected to the Battery connection.

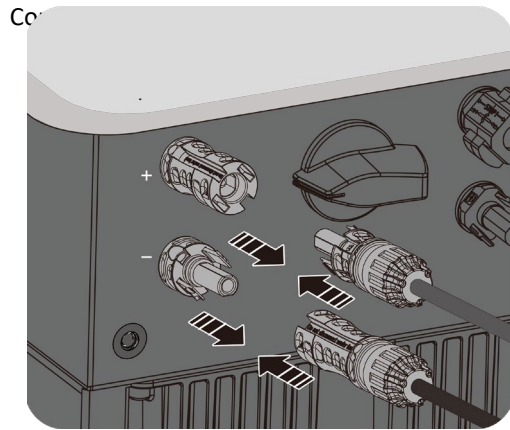

Fig. 41. Connecting the battery connectors

7.8 Creating equipotential bonding



NOTE

Depending on the local installation specifications, it may be necessary to earth the device with a second ground connection. To this end, the threaded bolt on the underside of the device can be used.

- ↻ The device has been installed on the mount.

- 1 Insert the grounding conductor into the suitable terminal lug and crimp the contact.
 - 2 Align the terminal lug with the grounding conductor on the screw.
 - 3 Tighten it firmly into the housing [\times W_5/ \uparrow 3 Nm].
- » The housing is included in the equipotential bonding

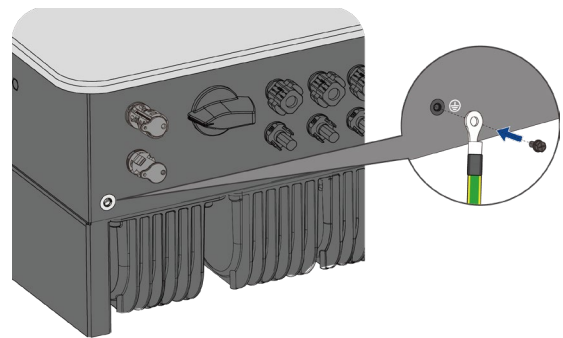

Fig. 42. Connect the grounding

7.9 Connecting the interfaces

7.9.1 Connect the Communication unit



⚠ CAUTION

Damage to the inverter due to electrostatic discharge

Components inside the inverter can be damaged beyond repair by electrostatic discharge.

› Earth yourself before touching the components.

⚠ CAUTION



Damage to the Communication unit due to rotation of the module housing

When the Communication unit is attached to the inverter, the nut on the Communication unit must be turned. The Communication unit can be damaged if you rotate the housing of the Communication unit.

› Do not rotate the housing of the Communication unit when attaching it to the device.

↻ The device has been installed on the mount.

1. Remove the cap on the COM1 connector (see Fig. 43).

2. Insert the Communication unit into the existing connection and screw it tightly into the connection using the nut on the Communication unit (see Fig. 44).

NOTE: Do not rotate the housing of the communication unit when attaching it to the device.

3. Ensure that the Communication unit is securely connected and the label on the device can be seen.

» The Communication unit is connected to the device.

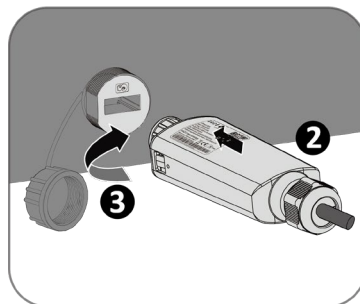

Fig. 43. Remove the cap

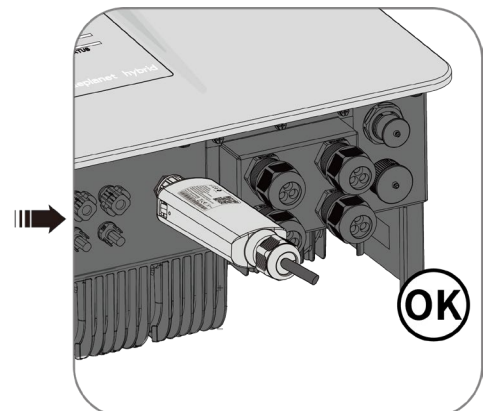

Fig. 44. Connect the Communication unit

7.9.2 LAN cable connection (optional)

↻ The device has been installed on the mount and remove the cap on the COM 0 connector.

1. Open the communication unit by pressing in the two release tabs on the housing (see Fig. 45).

2. Open the cable gland and remove the seal. Insert cable gland on LAN cable and attach seal for cable.

3. Feed the LAN cable through the housing of the communication unit and insert it into the plug in the LAN port on the circuit board. (see Fig. 46).

4. Close the housing using the two release tabs and fasten the cable gland [\times W_16/ \blacktriangleleft 2 Nm] (see Fig. 47).

5. Insert the communication unit into the corresponding connection and screw the unit tight with the nut.

NOTE: Do not rotate the actual Communication unit when attaching it to the device.

6 Ensure that the Communication unit is securely connected and the label on the module can be seen.(see Fig. 48).

» The Communication device is connected via LAN-Kabel to the device.

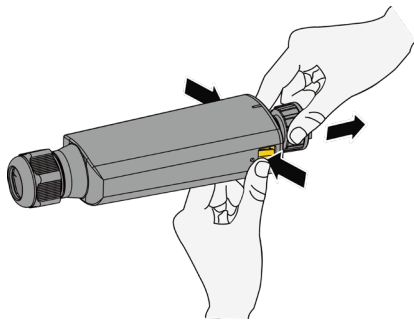

Fig. 45. Press in the release tabs on the communication device

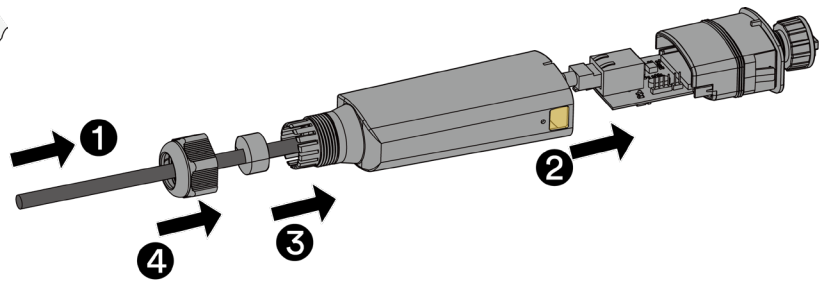

Fig. 46. Feed the LAN cable through the housing and connect the LAN plug

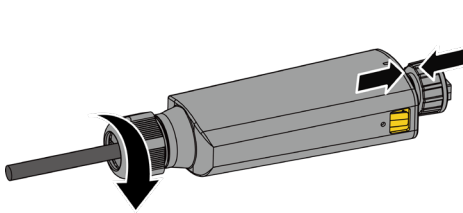

Fig. 47. Attach the seal and fasten the cable gland

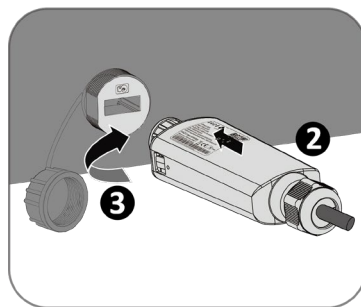
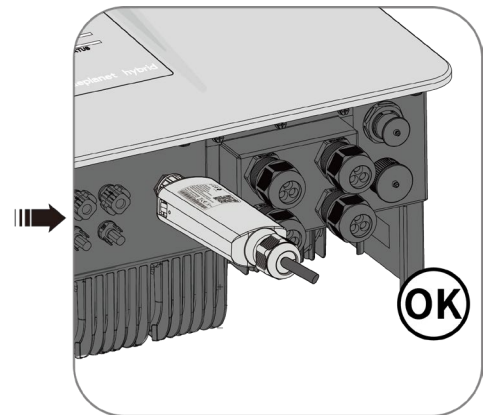

Fig. 48. Connect the Communication device



7.9.3 RS485 cable connection

CAUTION



Damage to the inverter due to electrostatic discharge.

Components inside the inverter can be damaged beyond repair by electrostatic discharge.

› Earth yourself before touching the components.



NOTE

A straight through network cable of category 5E or higher is required for connection to the RJ45 socket. A network cable with good resistance to UV radiation is also required for use outdoors.

The RS485 connection can support communication with a maximum installation length (across all inverters) of 1000 m. The individual and control connected must be measured in accordance with EMC requirements EN 62920 if the length of the cable attached at the signal and control connection is more than 30 m according to the standard.



NOTE

Ensure that the DATA+ and DATA- wires are properly connected. Communication is not possible if the wires are reversed! Different manufacturers do not always interpret the standard on which the RS485 protocol is based in the same way. Note that the wire designations (DATA- and DATA+) for wires A and B may vary from one manufacturer to another.

Port Introduction

All interfaces are located on the communication circuit board on the inside of the housing base.

"The device is equipped with a communication interface through which communication cables, lithium batteries, electricity meters, and parallel connections can be connected. The interface configuration of the communication interface is displayed. (see Fig. 49).

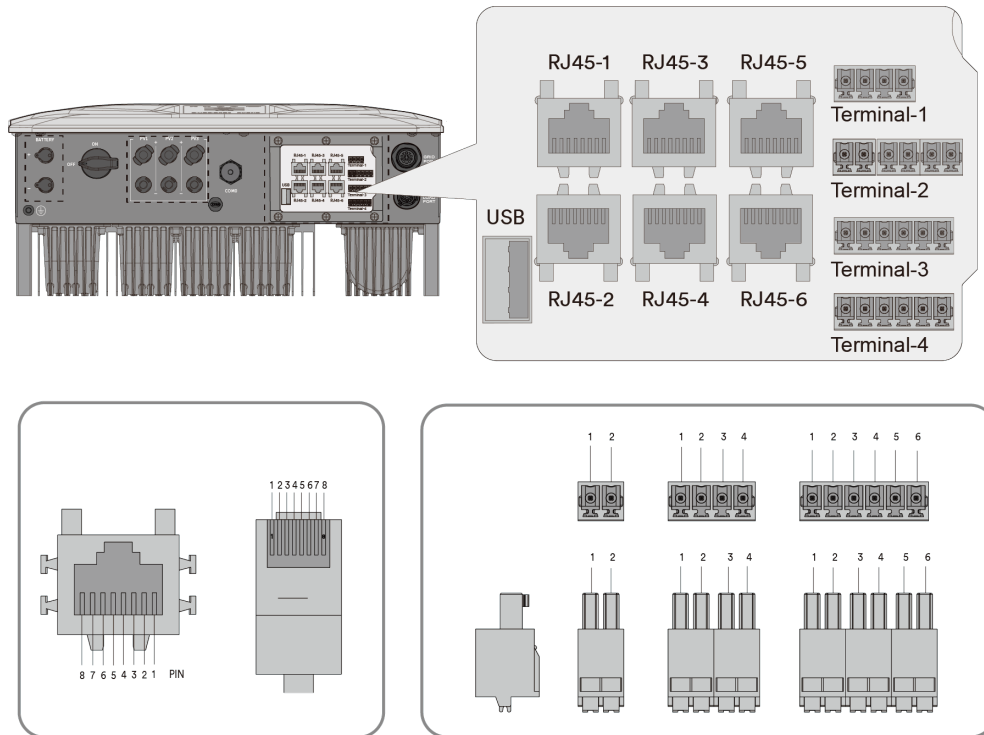

Fig. 49. Connection and assignment of the interfaces

Object	Description	Terminal	PIN definition							
			1	2	3	4	5	6	7	8
RJ-45-3	Monitor	COM2	RS-485A	RS-485B	GND	X	X	X	RS-485A	RS-485B
RJ-45-4	BMS	COM5	X	GND	X	CANH	CANL	X	RS-485A	RS-485B

Object	Description	Terminal	PIN definition					
			1	2	3	4	5	6
Terminal-1	DO1/DO2	4pin	Multifunction Relay 1		Multifunction Relay 2		/	/
			B	A	B	A	/	/
Terminal-2	/	6pin	Smart Meter		/		NS-Protection device	
			RS485A	RS485B			Positive	Negative
Terminal-3	DI*4/DRM0	6pin	Ripple Control Receiver Device				DRMS Device	
			DI_4	DI_3	DI_2	DI_1	REF GEN/0	COM LOAD/0 or GND

Com port	Description	Function
RJ45-1; RJ45-2 RJ45-5; RJ45-6	RS485 port	The RS485 interfaces used to the product parallel operation.

RJ45-3 Monitor device

The PIN1、 PIN2 of RS485 interface used to connect the product to the third-party monitor device. If you don't want to use communication device, the third-party monitor device can be used.

RJ45-4	BMS communication port	The CAN interface used to connect the BMS (Battery Manage System) of the battery. The CAN communication interface of the BMS must be connected to the RJ45-4 port via PIN 4.5 on the device.
Terminal-2	Smart Meter NS-protection (network and system protection) Device	Terminal 2 can be used to connect the smart meter, NS-protection (network and system protection) device. The PIN definition is shown as above table.
Terminal-3	Ripple control receiver device DRMs device	Terminal 3 can be used to connect the ripple control receiver and DRMs device. The PIN definition is shown as above table. Especially the PIN 6 (GND) is a common port for both devices.

7.9.4 Connecting the RS485 cable

🔄 The device has been installed on the mount.

1. Remove the communication cover from the inverter, store the removed screws properly (see Fig. 50) [⚠ M4 1.6Nm].
 2. Unfasten the cable fitting for communication connection (see Fig. 51).
 3. Route the communication cable through the communication cover and crimp the wiring terminal. The sequence of the crimping wires of the wiring terminals is shown in the following figure (see Fig. 52).
 4. Connect the communication cable crimped to the corresponding communication port.
 5. Check that the connecting cable is fitted securely.
 6. Lock the communication cover with screws, and finally tighten cable fitting.
- » The Communication unit is connected to the device.

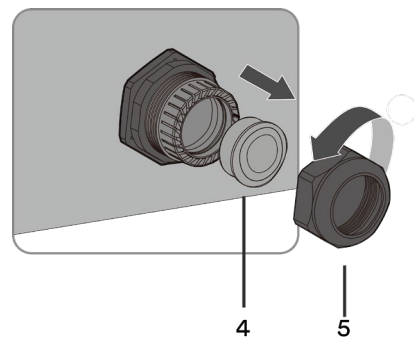
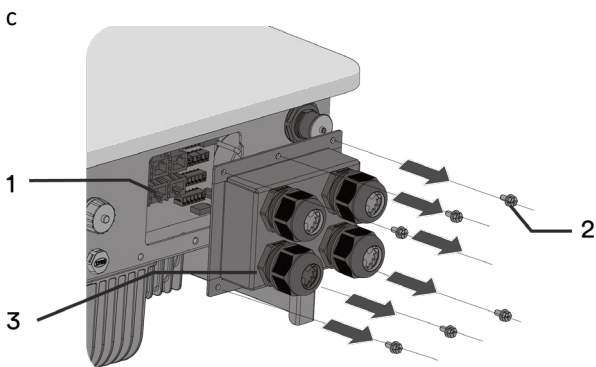

Fig. 50. Remove the communication cover

Fig. 51. Communication cable fitting

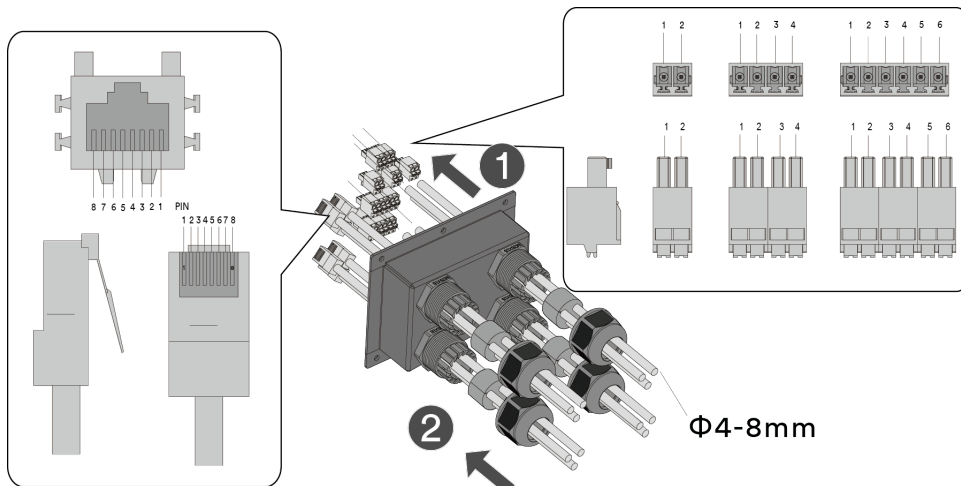

Fig. 52. Communication leads through the cable

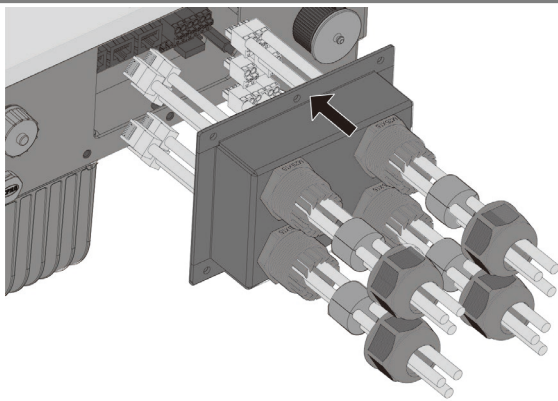

Fig. 53. Secure the communication cable to corresponding terminals

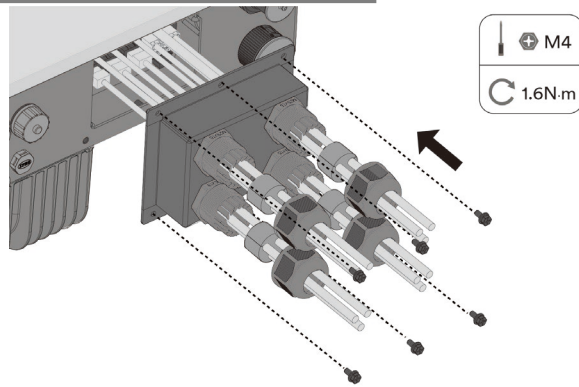

Fig. 54. Attach the AC/COM cover

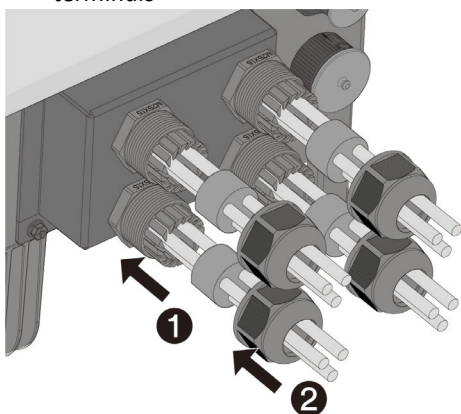
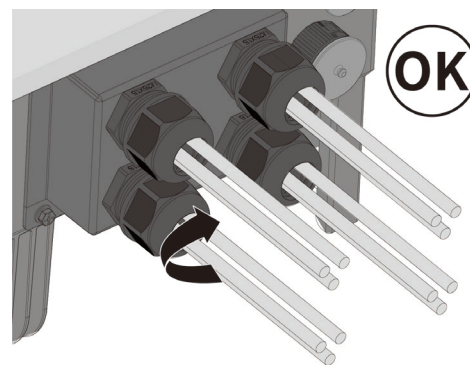

Fig. 55. Tighten the nut



Key

1 Housing base –communication side	4 Sealing ring
2 Screws for mounting	5 Nut
3 Communication cover	

7.9.5 RS485 cable connect to the Smart-Meter for dynamic feed

If you want to implement the function dynamically, you need to install the Smart-Meter. The Communication unit (Connect-NH) is only compatible with the **Eastron Smart-Meter (SDM630)**.



NOTE

The Smart-Meter must support the MODBUS protocol and communicates with baud rate 9600, parity “None”, Stop-Bits “1”

Ensure that individual wires at the terminal contact of the Smart-Meter are attached with the correct torque and cannot work loose. Attach protective cover if fitted.

↻ The RS485 cable is connected to the device and the Smart-Meter have been firmly installed on a mounting bracket.

↻ Make sure the AC cable is totally isolated from AC power before connecting the Smart Meter.

1. Strip the insulation of the other side from the network cable and screw copper wire to the corresponding terminal. Screwdriver type: PH0, tightening torque: 0.7 Nm (See Fig. 56)

» The RS485 connection established with the smart meter. Lay signal cable correctly.

Terminal-2

Fig. 56. RS485 cable connect to the Smart-Meter

7.9.6 BMS Connection

BMS is used to communicate with the connected compatible lithium battery.

The CAN interface used to connect the BMS (Battery Manage System) of the battery. Only BMSs that also have a CAN interface may be used.

↻ You have completed the battery storage unit to the device (refer to 7.7.1 Making the battery storage unit to the device).

↻ The Communication unit (RJ45-4) have been connected to the device. (refer to 7.9.3 CAN cable connection).

1. Strip the insulation of the other side from the network cable and screw copper wire to the communication interface of the lithium battery.

2. Select the corresponding battery via the APP (see chapter 9.8.5).

» The BMS(RJ45-4) is connected to the battery.

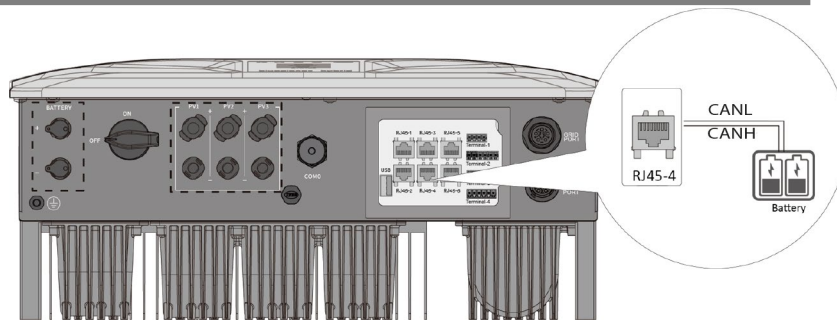

Fig. 57. BMS communication connection

7.9.7 Inverter Off connection



NOTE

The digital input of the device is intended for connection of a Powador-protection device. When using devices from other manufacturers or in combination with KACO inverters, interface switches as a minimum must be used for shutting down devices from other manufacturers.

The model UFR1001E from ZIEHL industrie-elektronik also can be supported.



NOTE

If the Powador-protection device is connected, the interface protection parameters must be set according to the associated application note “Application note powador-protect” in the download area on our website.



NOTE

A straight through network cable of category 5E or higher is required for connection to the RJ45 socket. A network cable with good resistance to UV radiation is also required for use outdoors.



NOTE

If several inverters connect to one Powador-protection device, One of the RS485 communication port (Terminal-2) of the first inverter connect to the Powador-protection device, the rest RS485 communication port connect to the next inverter. The other inverters connect one by one through the straight through network cable.

⌚ The device and the Powador-protection device have been firmly installed on a mounting bracket.

⌚ The Communication port (see Terminal-2) have been connected to the device (refer to 7.9.3 RS485 cable connection).

1. Strip the insulation of the other side from the network cable and screw copper wire to the corresponding terminal of the Powador-protection device. Screwdriver type: SL1.5, tightening torque: 0.6 Nm (see Fig. 59).

» The Communication port (see Terminal-2) is connected to Powador-protection device.

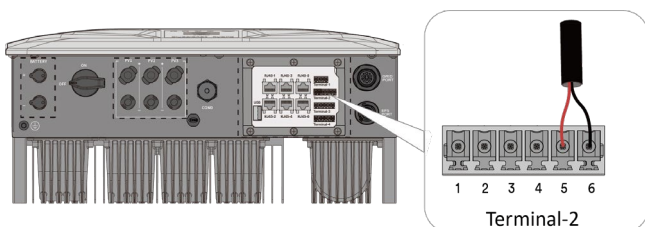

Fig. 58. Connect the network cable

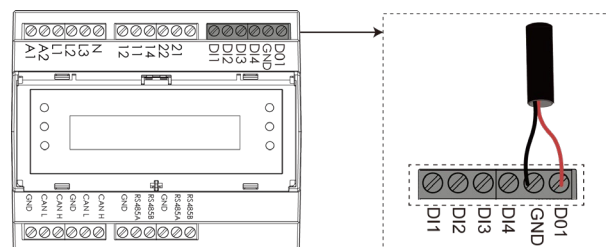

Fig. 59. Connect the network cable to Powador-protection device

⌚ Open the corresponding APP for these devices.

1. Select <Select inverter> in the <Communication device> menu.

2. The required device is selected in <Available inverters> and the <Settings for> menu is opened in the <Parameter settings> in the <Inverter details & settings> menu.

3. Select < Functions/Features > to go to the next screen.

4. Select < NS-Protection >
5. Enable the < NS-Protection > function. (See Chapter 9.9.19 on page 92)
- » NA Protection operation is enabled.



NOTE

In Austria grid code, Pin6 can be defined as GND, and pin5 can be defined as Remote off. The inverter will turn off after the Pin 5 and Pin 6 is short, and the inverter will operate normally after the Pin 5 and Pin 6 is open.

7.9.8 Ripple control receiver connection



NOTE

A straight through network cable of category 5E or higher is required for connection to the RJ45 socket. A network cable with good resistance to UV radiation is also required for use outdoors.



NOTE

If several inverters connect to one ripple control receiver, One of the RS485 communication port (see Terminal-3) of the first inverter connect to the ripple control receiver, the rest RS485 communication port connect to the next inverter. The other inverters connect one by one through the straight through network cable.

- ⌚ The device and the ripple control receiver have been firmly installed on a mounting bracket.
- ⌚ The Communication port (see Terminal-3) have been connected to the device. (refer to 7.9.3 RS485 cable connection).
- 1. Strip the insulation of the other side from the network cable and screw copper wire to the corresponding terminal of the ripple control receiver. (see Fig. 61).
- » The Communication port (see Terminal-3) is connected to ripple control receiver.

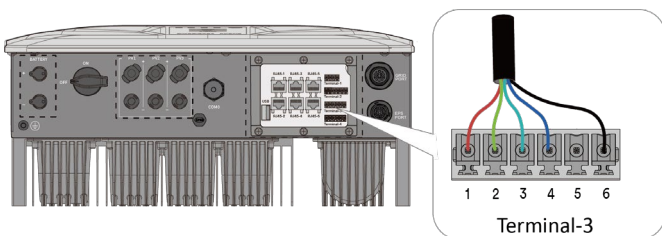

Fig. 60. Connect the network cable

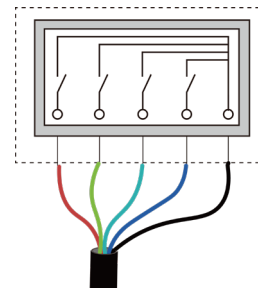

Fig. 61. Connect the network cable to ripple control receiver

WARNING! Incorrectly performed connections can cause damage to the hardware. External components must not deliver more than 5 mA per input channel.

⌚ Ripple control receiver is professionally mounted&installed.

- 1 Comply with the cable requirements:
Max. cable cross-section 1.5 mm²; insulation length 9 mm
Max. cable length when 0.5 mm²: 100 m
- 2 Attach connection leads to the corresponding connection terminals (DI1 ... DI4, GND).

Samples: (In case of all inputs are configured as ACTIVE LOW):

- All inputs is open -> P_{out}=100%,
- UDI1=24V; UDI2=0.8V; UDI3=24V; UDI4=36V -> P_{out}= 60%,
- DI3 at GND; DI1, DI2, DI4 open -> P_{out}= 30%,
- All inputs on GND ->P_{out}= 0%

» The ripple control is correct connected

D1 (1)	D2 (2)	D3 (3)	D4 (4)	Output power (in % of the AC _{CRPO})	Note:
0	0	0	0		
1	0	0	0	100 %	
0	1	0	0	60 %	
0	0	1	0	30 %	
1	1	0	0	0 %	
1	1	1	1	0 %	

Table: 1. Configure power level

8 Commissioning

8.1 Requirements

DANGER



Lethal voltages are still present in the connections and cables of the device even after the device has been switched off and disconnected!

Coming into contact with the lines and/or terminals/busbars in the device can cause serious injury or death.

- › The device is only permitted to be commissioned by a qualified professional.
- › Unauthorised persons must be kept away from the device.

↻ The device has been mounted and electrically installed.

↻ The PV generator supplies a voltage above the configured start voltage.

1 Connect the grid voltage using the external circuit breakers.

2 Connect the PV generator using the DC isolator switch (0 > 1)

» The device begins operation.

» During initial start-up: Follow the instructions in the associated application note – Installing and using the app.



NOTE

For initial start-up of the device, the enclosed Communication unit must be plugged into the connection port.
A mobile terminal device with a WIFI interface is required for monitoring and setting parameters. No serial number dependent password is required here.

The following functions are only available via the associated app:

- Initial start-up.
- Setting parameters
- Special parameters (e.g. P(f), P(U), Q(U))
- Reset to Factory defaults.

8.2 Preconditions relating to standards

Attachment of safety label in accordance with UTE C15-712-1

The code of practice UTE C15-712-1 requires that, upon connection to the French low-voltage distribution network, a safety sticker showing a warning to isolate both power sources when working on the device must be attached to each device

- Attach the safety sticker provided to the outside of the device housing where it is clearly visible.

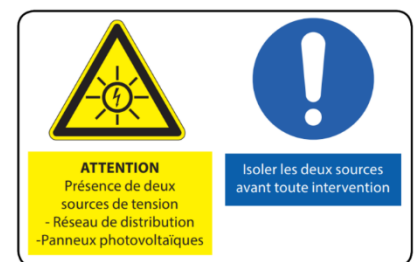

9 Configuration and operation

9.1 Start condition

↻ The Communication unit is connected to the device and firmly screwed in place.

↻ The device is connected on the AC and DC sides and supplied with sufficient DC voltage.

Note: Note the status of the LED during initialization, during operation and in the event of fault messages. This can provide you with accurate information about the current operating status of the device.

1 Check on the Communication unit that the blue LED lights up during the initialization process. If not, check the fastening again. Otherwise, replace the Communication unit.

2 Check on the device that the blue LED lights up in feed mode. If not, there is a fault in the device.

Note: In case of faults, refer to the error code in the chapter 10.5.

» Continue to set up the device monitor.

9.2 Initial start-up

Initial start-up of the inverter is carried out via a hotspot WLAN connection between the Communication unit connected to the inverter and a mobile terminal unit with installed “KACO NH Setup” APP.

Step 1: Establishing a connection with the Communication unit.

There are two ways to connect with the hotspot created by this unit:

- Establish a simplified connection with the Communication unit by opening the APP and reading in the QR code on the Communication unit with Setup Mode. After scanning the QR code, you will be shown a WLAN network with the name **B....** . When selecting this WLAN network, it is not necessary to enter a password. Your mobile device will connect to the device automatically. Further information see chapter 9.6.2 on Page 54
- Connect by opening the WLAN settings on the mobile terminal device and selecting the WLAN connection with the designation **B....** and entering the password (registration code).
Note: The name SSID (serial number of the Connect-NH B...) and password (registration code) of the Communication unit can be found printed on the Communication unit.
 » You are successfully connected to the Communication unit.

Step 2: Configuring the Communication unit and inverter

We recommend the following steps for the initial start-up:

- **Configuration Communication device**
 - Set up time zone. See Chapter 9.7.3 on Page 58.
 - Configure network parameters See Chapter 9.7.2 on Page 57.
 - Setting the monitoring and control functions See Chapter 9.7.7on page 62 (Monitoring & Control)
- **Configuration Inverter**
 - Select country and grid standard See Chapter 9.9.1on page 70.
 - Set local grid requirement (observe local grid requirements! E.g. cos-phi, P(f), Q(U)....) See Chapter 9.9.12on Page 81
 - View the instantaneous values of the inverter in order to detect any faults. See chapter 9.8.1 on page 65.



NOTE

For further settings such as power control, zero-feed in or communication with a data logger, please refer to chapter 9.9.21.

9.3 Authorisation



NOTE

In order to use the full range of functions of the “KACO NH SETUP” app, you should accept all requested authorisations. The app does not use these authorisations to record the user’s telephone data. The current description reflects the firmware version **2.0.0.009** With newer firmware versions the following subchapters will be updated in time to inform you about current functions.



NOTE

Our KACO website offers a wide range of further device information to assist you during start-up. You can find this information in the download area under: <https://kaco-newenergy.com/de/downloads/>.

Follow the **QR code link** on the cover sheet to view the installation and start-up video.



NOTE

TCP port 443

Used for encrypted communication (HTTPS) between the device and the mobile app. This is a fundamental device function. The service is automatically enabled when the device is powered on and disabled when powered off, and no separate interface is provided for manually enabling or disabling it.

TCP port 502

Used for encrypted Modbus TCP communication. This port is enabled only when Modbus TCP mode is selected in the app and the device successfully connects to the network (obtains an IP address); otherwise, it remains closed.



NOTE

No password is required for **initial start-up**. A password must be entered again if it becomes necessary to change the parameters of the device after initial start-up.
The specific password for the inverter can be requested from KACO Service. <https://kaco-newenergy.com/de/service/kundendienst/>



NOTE

Frequency band

Before configuring the network, make sure that the WLAN router supports the 2.4G frequency band. The Communication unit can only be operated in the 2.4G frequency band.

Installation location

For a stable connection, the Communication unit or inverter should be no more than 10 m away from the router.

Availability of SSID and password of the router

The Communication unit supports only 32 characters for the SSID or password.



NOTE

We recommend integrating the Communication unit into your/your customer's WLAN network, if the signal quality of the network is insufficient or non-existent, then you will need to continue with hot-spot connection.

To use monitoring and control functions (Monitoring Portal "KACO blueplanet Smart Cloud"), there must be a connection to the internet via the customer's WLAN network.

9.4 Operating system and system configuration

The corresponding, free APP **KACO NH Setup** from the relevant APP store can be installed on a mobile terminal unit (smartphone or tablet PC) with an **Android operating system, version 9.0 or newer** or **IOS operating system version 11.0 or newer**. You will find QR code links on the cover sheet.

Below you will find illustrations of the connection options for initial start-up of the device and its optional integration into a local network.

If you integrate the device into a local network, it is possible to connect the device to a web portal or a client (data logger, system controller).

Option 1: Set-up via hotspot (with APP connection to the inverter with Communication unit (Connect-NH))

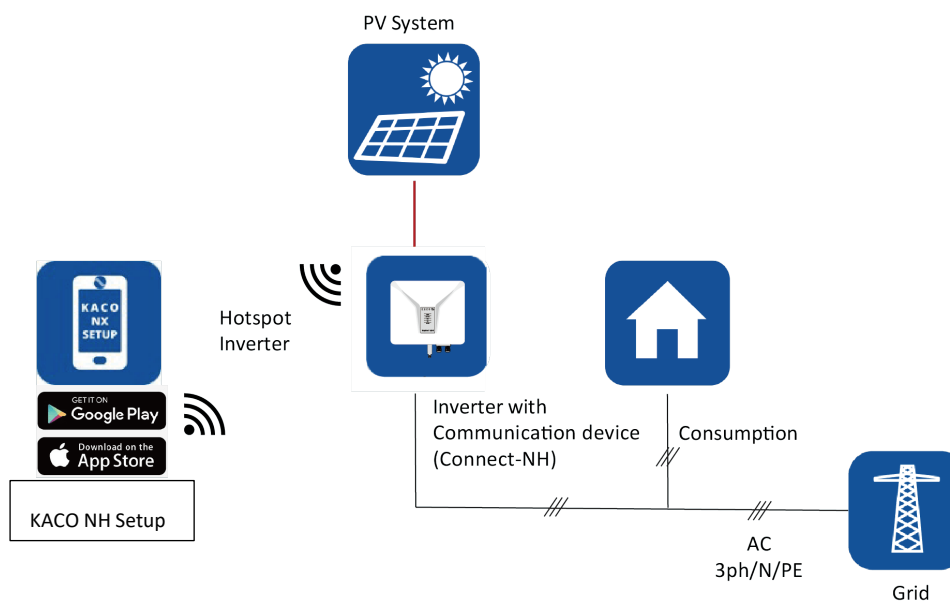

Fig. 62. Set up Communication unit (Connect-NH) via mobile end device – hotspot

Option 2: Set-up via local network

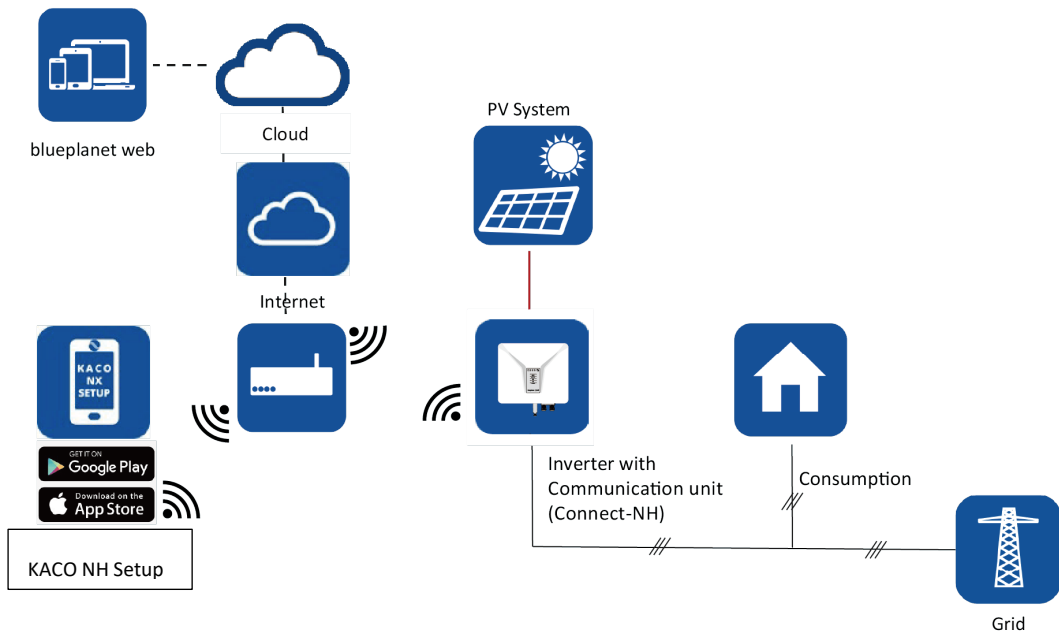



Fig. 63. Set up Communication unit (Connect-NH) via local network – WiFi 2.4G



NOTE

Please note the additional documents for the communication structure with and without data logger. These can be found in the download area on our homepage in the device order under application note.

9.5 Signal elements

There are status LEDs on the Communication unit and on the inverter housing that indicate the operating status. The LEDs can display the following states:

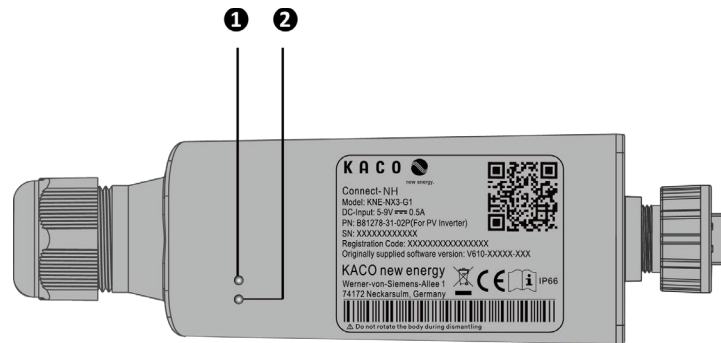







Fig. 64. LEDs on Communication unit (Connect-NH)

Item	Operating status on communication unit	LED	Description
1	Network communication		The blue LED lights up while searching for the IP address and when a connection to the web portal or client is established (data logger, EMS, etc.).
			Blue LED flashes when there is a connection with a local network (router). <ul style="list-style-type: none"> The Communication device has been configured in the WLAN network and is currently establishing a connection to the router. The Communication device is connected to a local network (router) but does not yet have an active connection to the web portal or client (data logger, EMS, etc.).

		<p>Note: For AP network configuration, you must be connected to the device's local WLAN network to re-enter the router information. The password for the local WLAN network is the registration key found on the name plate (See Fig. 74 on communication device).</p>
		<p> Blue LED is off: The communication device is in AP mode. The communication device forms a hot spot for a direct communication connection. Reasons for this could be.</p> <p>Modbus TCP mode, no client connect to stick</p> <ul style="list-style-type: none"> • The communication device has not yet been integrated into a local network. • The communication device was integrated into a local network but could not connect to the local router within 100 seconds (e.g. bad communication device connection or incorrect access data). <p>Note: After the 100 seconds have elapsed, the communication device (NH-Connect) switches to AP mode for 15 minutes and forms a hot spot for direct communication connection. In AP mode, it is possible to carry out the network configuration again.</p>
2	Device communication	<p> The green LED lights up. The LED indicates the communication status between the communication device (NH-Connect) and the inverters connected to the RS485 bus.</p> <ul style="list-style-type: none"> • The Communication device (NH-Connect) has an active connection to all inverters that are stored in the communication device (NH-Connect). <p> The green LED flashes. This has the following cause:</p> <ul style="list-style-type: none"> • Reset, restart or firmware update of communication device (NH-Connect) in process. • Not all inverters stored in the communication device (NH-Connect) are accessible. <p> The green LED is off. The communication device (NH-Connect) has no connection to all inverters known to it that are connected to the RS485 bus. This has the following cause:</p> <ul style="list-style-type: none"> • Communication device (NH-Connect) has no voltage supply (DC voltage at the inverter too low or DC switch OFF), which means that there is no AC voltage and no DC voltage from the battery. • Update information: After the files are uploaded, the communication unit performs a reset. The LED turns off for a few seconds before lighting up again. • RS485 bus connection to all known inverters interrupted. • Communication device (NH-Connect) not mounted correctly or defective, or RS485 interface of the inverter defective.

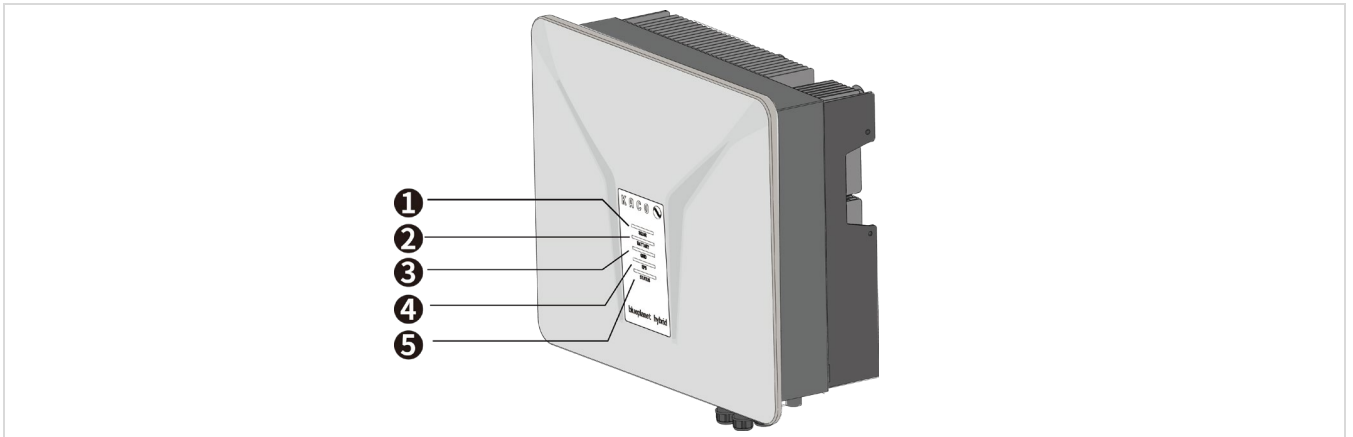

Fig. 65. LEDs on device

Operating status on the device					
1	2	3	4	5	
SOLAR	BATTERY	GRID	EPS	Status	Description
					The blue LED is on. The device operates normally and the solar energy, battery energy and grid are available. EPS Port is operation normally.
					The blue LED is blink. There are several scenarios: a. The device is self-checking automatically; b. The firmware is updating;
					The blue LED is blink. The firmware is updating.
					Solar energy input voltage or current abnormal.
					The blue LED is blink. Battery SOC low or working abnormally.
					The blue LED is blinking. The output of the EPS port of this device is overloaded.
					The blue LED is blink. The inverter is derating.
					The blue LED is off. The solar energy is not available.
					The blue LED is off. The battery energy is not available.
					The LED is off. The device is disconnected/the power grid is unavailable.
					The LED is off. The EPS port of the device stop operation.
					The grid blue LED is on. The device connects to the Grid normally.
					The EPS blue LED is on. The EPS port of this device is operating normally.
					The red LED is on. The device has system error/warning in on-grid mode.
					The red LED is on. The device has system error/warning in off-grid mode.
					The red LED is blinking. The device has critical error (e.g. HW defect) in on-grid mode.
					The red LED is blinking. The device has critical error (e.g. HW defect) in off-grid mode.
					The red LED is on. Solar failure, grid failure, battery failure or warnings for this device.
					The LED is off. All other cases.

9.6 Connecting to the device

9.6.1 Simplify commissioning

↻ WLAN of your mobile device is enabled and any existing customer WLAN network router is switched on.

Note: The initial connection is generally made via a hotspot.

↻ The “KACO NH Setup” APP from the Android/iOS Store has been installed and opened on your mobile end device.

↻ The Communication Device is connected to the COM0 port of the device. (see Chapter 7.9.1 on page 38)

Note: Each device in the device series must be configured with the **enclosed** Communication Device. Thereafter there is a fixed assignment to the device.

↻ The access details for your / your customer’s WLAN network are to be made available to the solar installer.

1. Select < Configuration >.

2. Click the <+> button. Grant authorisation for use of images, videos and camera.

Note: Users can click on the icon in the upper right corner for newbie orientation.

3. Scan the QR code on the Communication Device. Max. distance from the scan frame shown in the scan window. See Fig. 68

» The connection to the hotspot WLAN is established (B...).

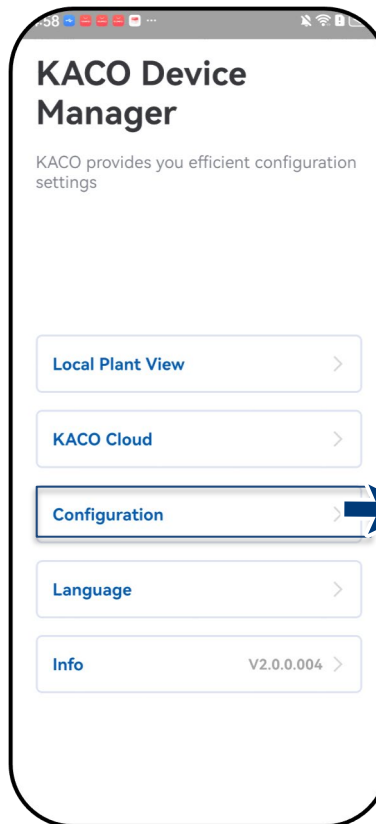

Fig. 66. Select <Configuration>

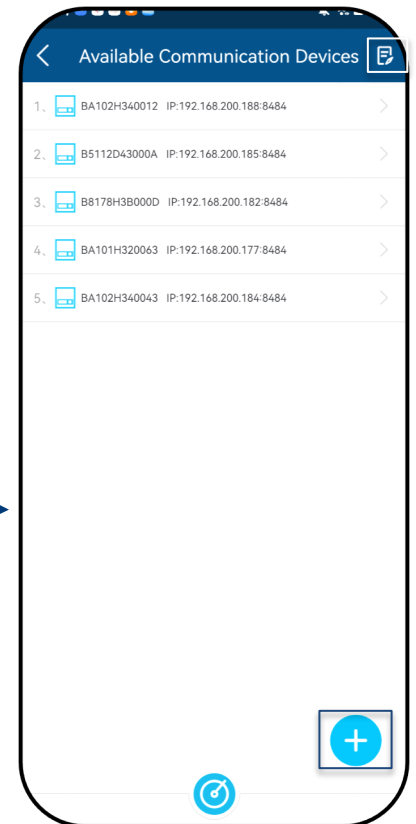

Fig. 67. Click the <+>

Note: The connection is established exclusively via the hotspot until **step 6**. This is how long your mobile end device must be kept near the Communication Device.

4. Confirm the WLAN network of the Communication Device by tapping the **B...** number displayed.

Note: After a short time you will have 2 options in <Network Configuration>.

Option 1- Connect the Communication Device to the local WLAN network.

Option 2 –Use the existing hotspot: Now follow the instructions in Chapter 9.6.2 on page 54

5. Select <Select network>. The customer needs to enter the password and press the <Confirm> button.

Note: If the connection fails, the Communication Device is not in range of the customer's router. You can improve the signal quality between the Communication Device and the router by interposing a **repeater**. However, this must also be connected to the same network.

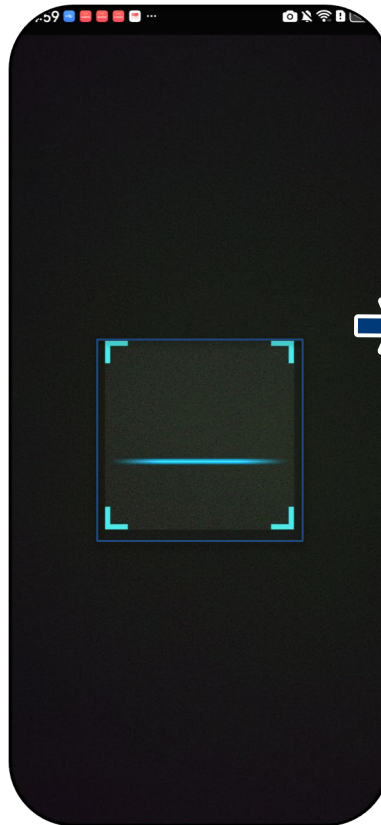

Fig. 68. Scan QR code

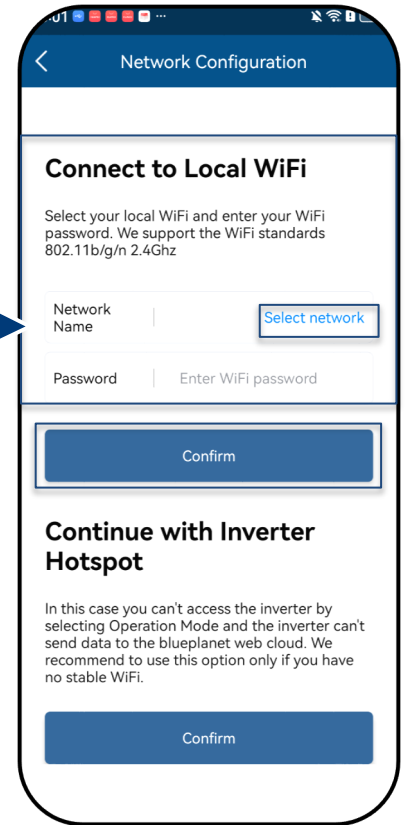

Fig. 69. Enter the access data for the customer's WLAN network

Note: If the connection is successful, your Communication Device will be connected to the customer's WLAN network. Your mobile end device now also needs to be connected to the customer's WLAN network.

6. In <Settings> on the mobile end device, you now need to establish a connection with the customer's WLAN network.

Note: The password is pre-filled if a connection already exists.

7. Note the checklist and status. Process takes up to 5 minutes.

» Your Communication Device and your mobile end device are now on the same customer WLAN network. A successful connection is displayed in a new window.

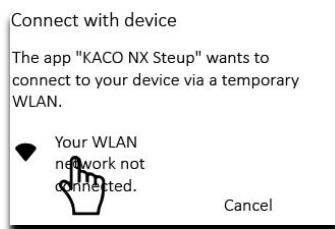

Fig. 70. Connect the inverter to the customer's WLAN

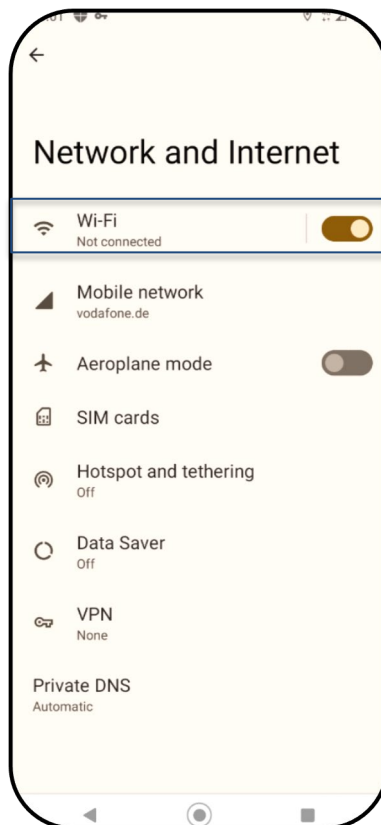

Fig. 71. Connect the mobile end device to the customer's WLAN

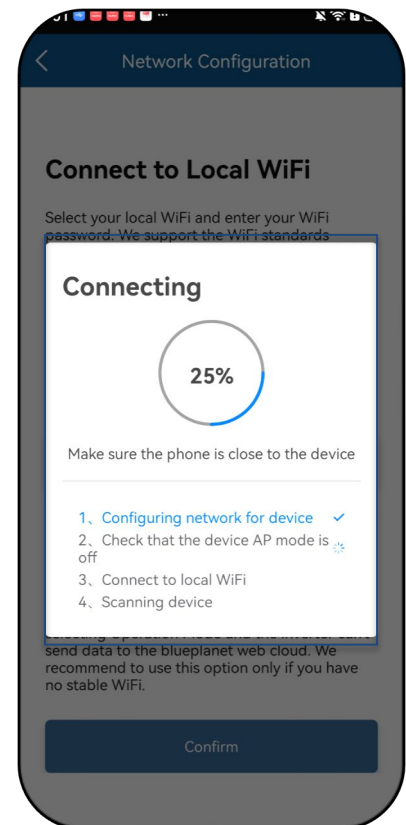

Fig. 72. The connection to the customer's WLAN network is established

Note: <Network configuration> displays information on the device serial number, software version and system time. If the system time is different, you can set it under <Time Zone Settings>.

8. Select <Confirm> that the Communication Device has been successfully connected to the customer's WLAN network.

Note: After a successful connection, the green LED on the Communication Device lights up continuously and the blue LED flashes. Please also refer to the description of the signal elements in Chapter 9.5 on page 49

Note: The software version is the firmware version of the Communication Device. You can update these as described in Chapter 9.10 on page 96 to bring the device up to the current functional status.

» The Communication Device is registered on the customer's WLAN network.

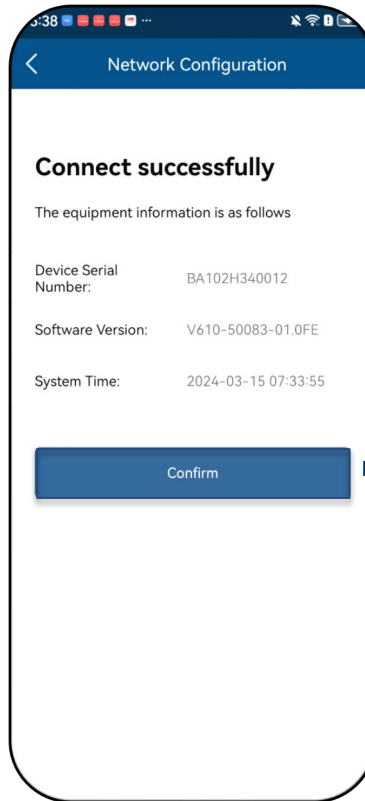

Fig. 73. Status when connection is successful



Fig. 74. Connection established – blue LED flashes.

9.6.2 Connecting the device via a hotspot (alternative)

Note: We recommend connecting the Communication device to the customer's WLAN network.

However, if the signal quality of the network is insufficient or non-existent, you can connect the unit using a hotspot connection.

⌚ The “KACO NH Setup” APP from the Android/iOS Store has been installed and opened on your mobile end device.

⌚ A password is not required. However, you must be standing right next to the device to establish a connection.

1. Carry out action steps 1- 4 from Chapter 9.6.1 on Page 52.

2. Establish the hotspot connection by pressing <Confirm>.

Note: If no Communication Device is found, your mobile end device may not be close enough to the inverter.

» The Communication Device is connected to your mobile end device.

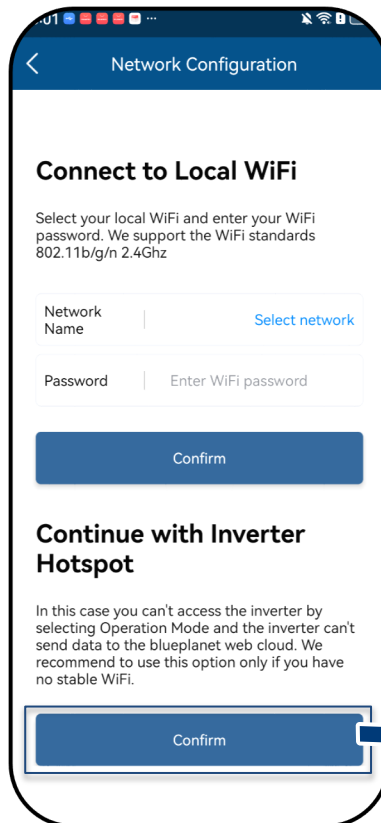

Fig. 75. Confirm inverter hotspot connection

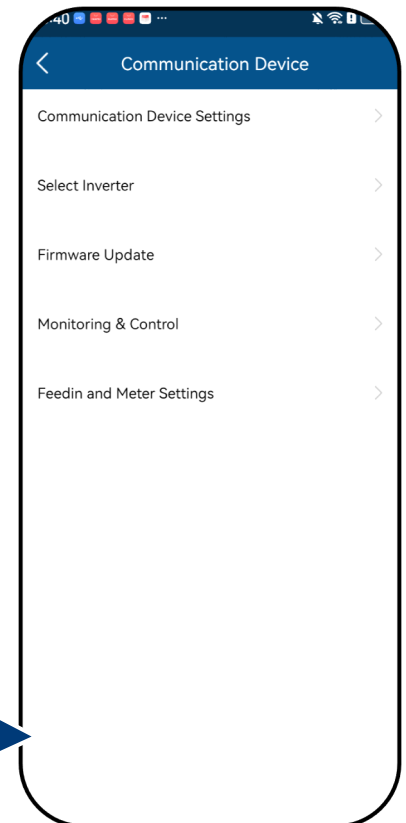

Fig. 76. Connection to the Communication Device established.

9.6.3 Connecting the device via LAN (alternative)

Note: However, if the signal quality of the network is insufficient or non-existent, you can connect the unit via LAN connection.

↻ LAN connection cable connected to the communication unit as described in chapter 9.6.2.

↻ A password is not required.

» The Communication Device is connected to your mobile end device.

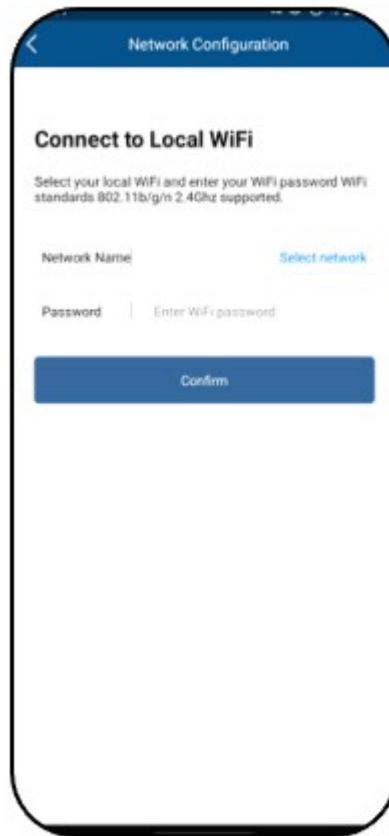

Fig. 77. Confirm inverter via LAN connection

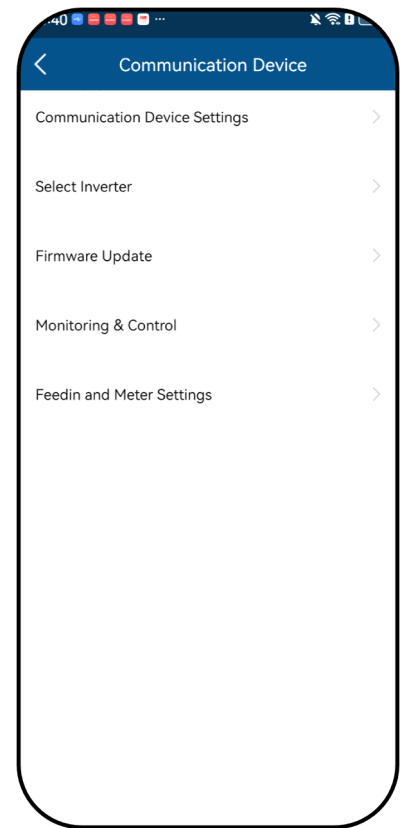

Fig. 78. Connection to the Communication Device established.

9.7 Menu of the Communication Device

Note: In both cases you now have access to the Communication Device. This is where you can make settings that do not directly affect the function of the inverter.

Note: Observe the step-by-step procedure for initial commissioning in chapter 9.2 on Page 47

Note: After completing or exiting initial start-up, the serial-number-based password is required to set further parameters. See Chapter 9.8.2 on page 66.

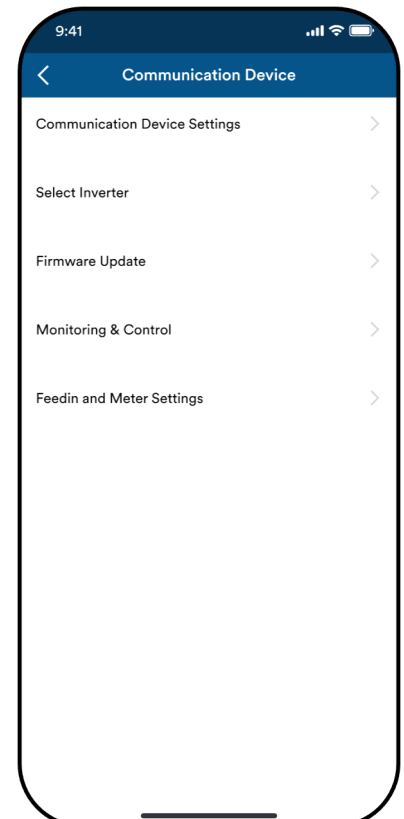

Fig. 79. Menu of the Communication device

9.7.1 Changing the customer WLAN network

↻ <Communication Device> menu is open.

Note: This allows you to change the WLAN configuration when you replace the device, router or your mobile device.

1. Select < Communication Device Settings >.

2. Select < Network Configuration >.

3. Select < Select Available Network >.

4. Select the network in the <Network Name> field using the drop-down menu.

5. Enter the password for the network and save the change with <Confirm>.

Note: If the router is defective or no longer reachable and the Communication Device cannot establish a connection and the blue LED lamp on the Communication Device does not light up, you can find the SSID of the Communication Device hotspot with the serial number of the Communication unit in your WLAN list. You can establish a connection with the hotspot of the Communication Device by entering the registration code on the label as a password.

Note: Data is transferred after approx. 30-60 minutes.

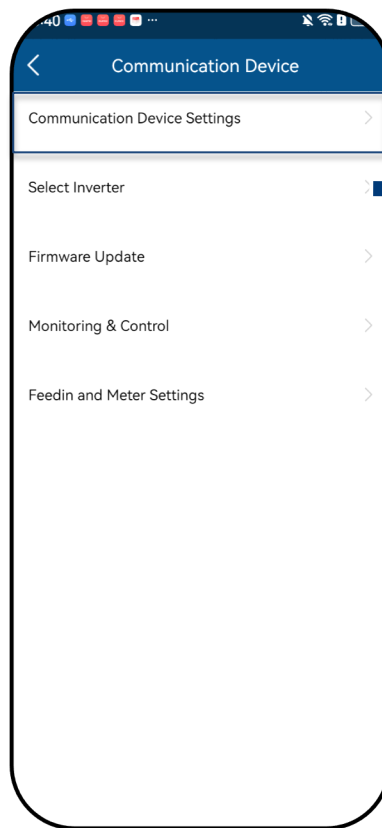

Fig. 80. Select communication device settings



Fig. 81. Select network configuration



Fig. 82. Select available network

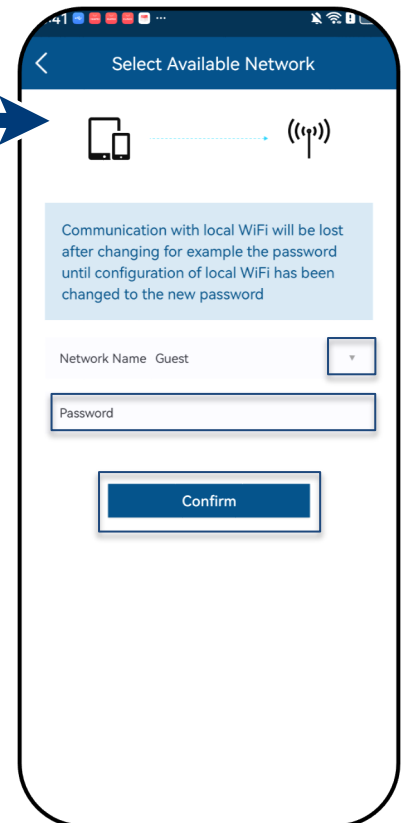

Fig. 83. Change network

9.7.2 Configure network parameter

Note: Here you can assign a static IP address to the inverter so that your router always uses the same address.

🔄 Connection to the communication device established

🔄 <Communication Device > menu opened.

1. Select < Communication Device Settings >.
 2. Select < Network Configuration >.
 3. Select < IP Settings >.
 4. <DHCP> for automatic IP address assignment or for more security.
 5. <DHCP> deactivate <DHCP> and enter IP address for your inverter.
 6. Optionally: Enter primary DNS address.
- » IP settings successfully carried out.

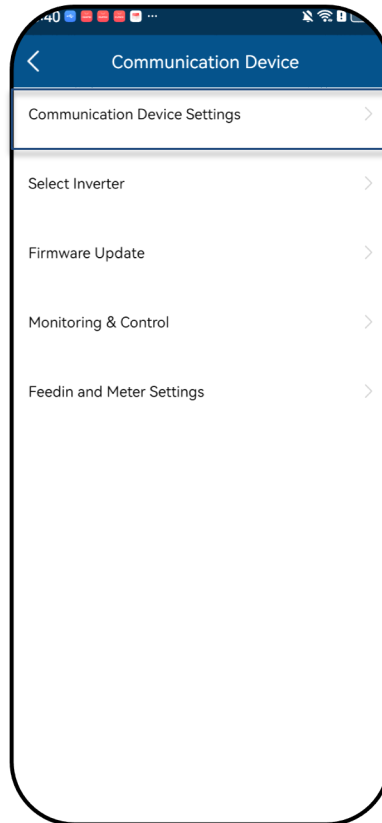

Fig. 84. Select communication device settings



Fig. 85. Select network configuration



Fig. 86. Select IP settings

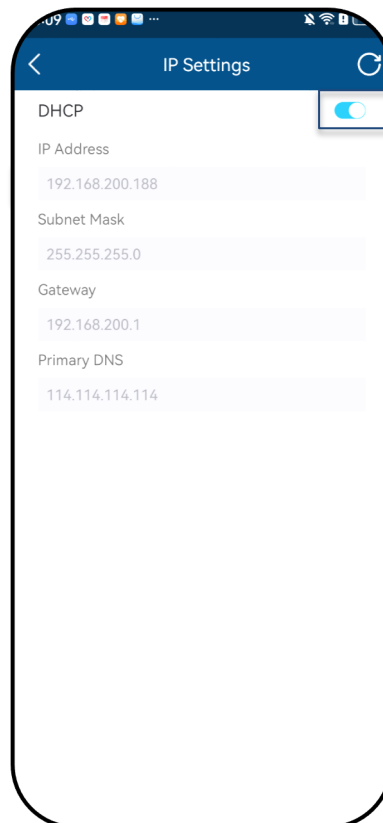

Fig. 87. Deactivate DHCP

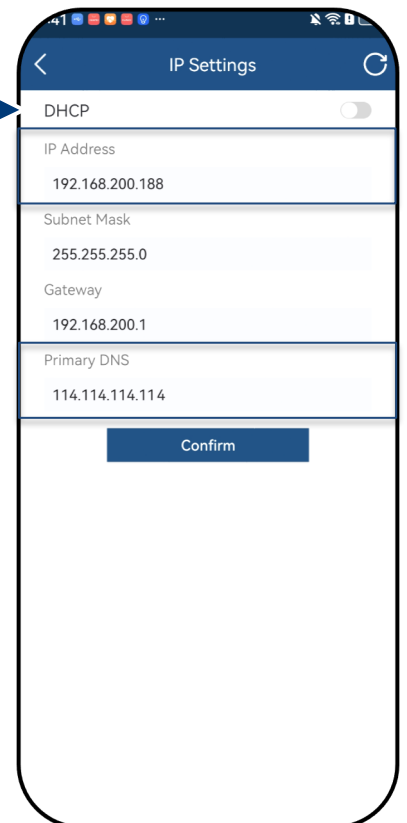

Fig. 88. Set IP address and DNS address

9.7.3 Setting the time zone

Note: The time communicated by the network is GMT. You should now adjust the time zone depending on the installation location. This time is also used for the display on the “KACO blueplanet smartcloud” portal.

↻ <Communication Device> menu is open.

1. Select < Communication Device Settings >.

2. Select < Time Zone Settings >.

3. Select < Time Zone >. For Germany, this would be: Amsterdam, Berlin...

4. Confirm the selection with < Confirm >.

Note: If the internet is not available on the network, you will have to make the changeover to summer/winter time manually.

» Time zone set.

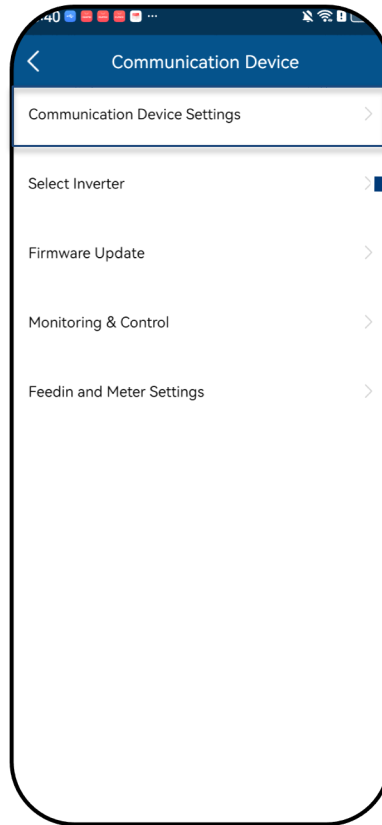

Fig. 89. Select communication device settings

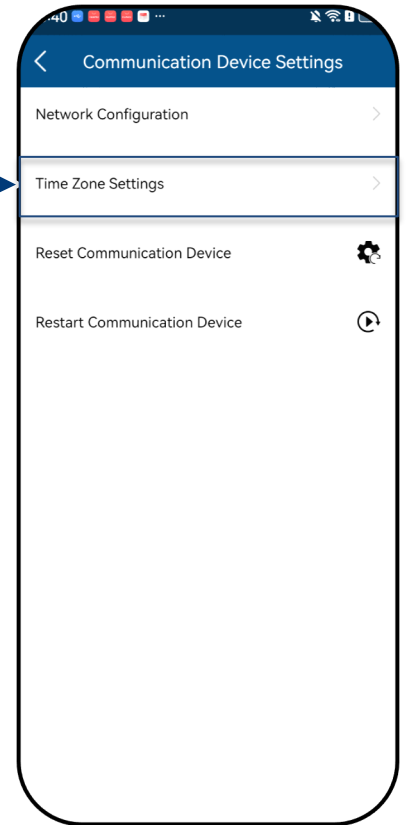

Fig. 90. Select time zone settings



Fig. 91. Select Time Zone



Fig. 92. Set Time Zone

9.7.4 Resetting a faulty connection

 <Communication Device> menu is open.

Note: The Communication Device is restarted via the <Restart Communication Device > icon. Set values on the device are not reset.

1. Select < Communication Device Settings >.

2. Select < Reset Communication Device >.&< Restart Communication Device >

3. Press the <Confirm> button in the warning message to trigger a restart.

Important: Pressing <Reset Communication Device> resets all created configurations to the factory defaults.

4. Reset the Communication Device with <Reset Communication Device >.

» Check the connection after restart.

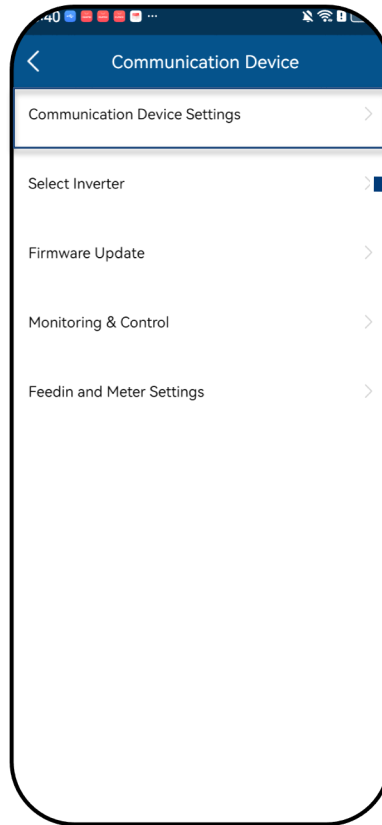

Fig. 93. Select communication device settings

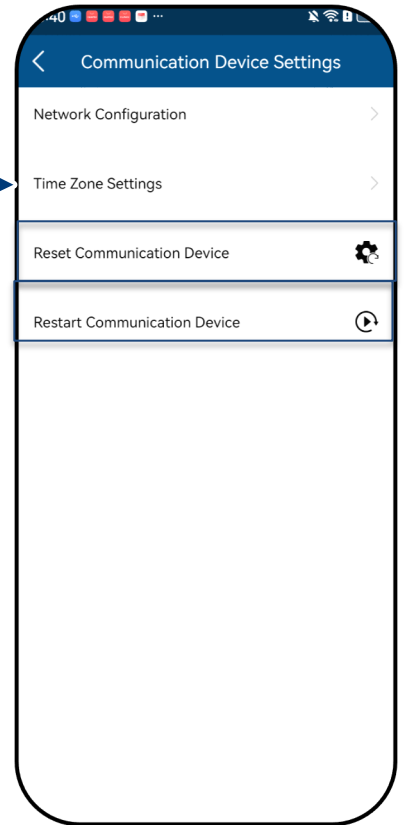

Fig. 94. Reset / Restart communication device

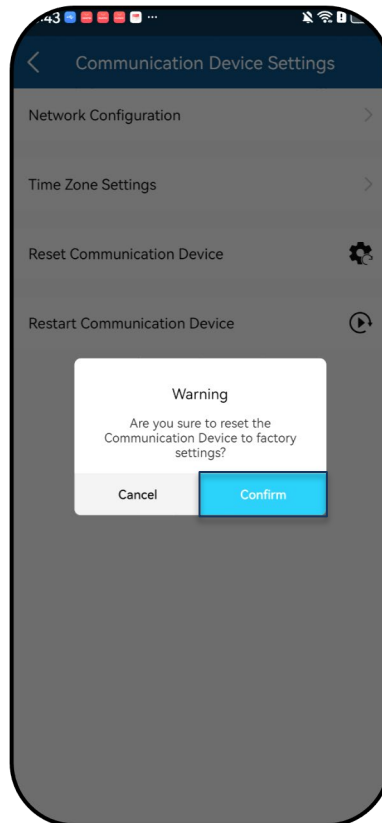

Fig. 95. Observe the note on resetting the Communication Device!

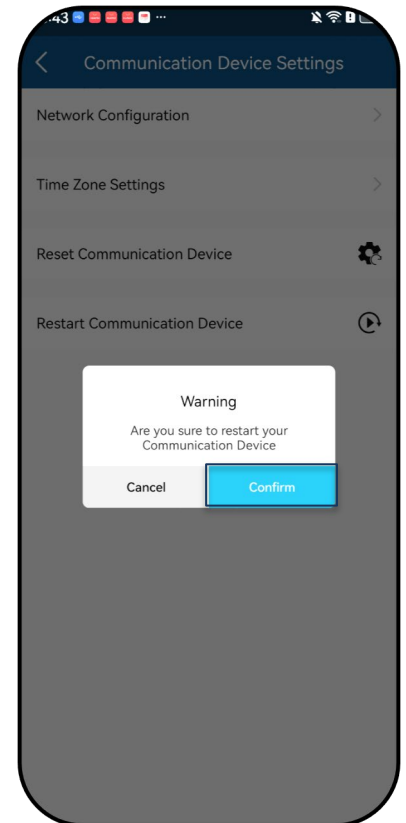

Fig. 96. Observe the note on restarting the Communication Device



NOTE

The following settings are **reset** when the Communication Device is reset:

- Network Configuration
- Feedin and Meter Settings
- Monitoring & Control
- Time Zone settings
- Internal inverter list from the Communication Device is deleted from the memory.

Note: Inverter settings are not reset by the Communication Device during a restart.

9.7.5 View available inverters

- ↻ All inverters are connected via a Communication Device.
- ↻ <Communication Device> menu is open.
 1. Select < Select Inverter >.
 2. Press the <Scan inverters > button.

Note: Up to 5 inverters can be connected to one Communication Device. When the button is pressed, the Communication Device scans the connected inverters and automatically assigns the RS485 address and saves it in the Communication Device.

 3. The desired inverter can now be selected for further parameter settings under <Available inverters>.
 4. Adjust the parameters in <Parameter Setup>.
 - >> see Chapter 9.7.9 on page 64 or: View feed-in values of the selected device in <Instantaneous Values> >> see Chapter 9.8.1 on page 65.
 - » Device configured with country setting.

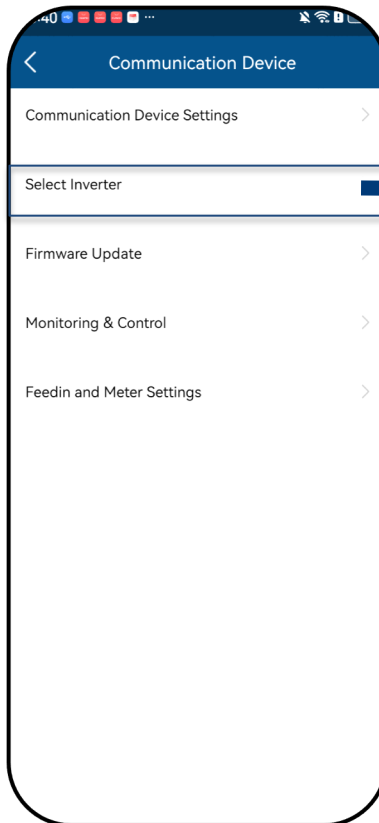

Fig. 97. Select inverter

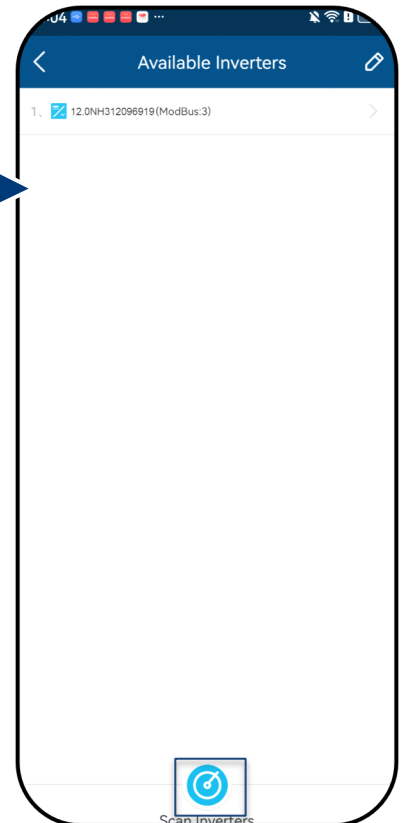

Fig. 98. Select the required inverter

NOTE

Scan device in Available Inverters page



Under normal circumstances, you do not need to search for devices.

You might lose your previous inverter list and data due to the following cases:

- › Communication Device has no communication with the inverter.
- › You have added a single inverter/multiple inverters to the Communication Device.
- › You have removed a single inverter/multiple inverters to the Communication Device.
- › You have replaced a single inverter/multiple inverters to the Communication Device.

9.7.6 Manually adjusting the Modbus address

 <Communication Device> menu is open.

Note: By default, the Modbus address "3" is stored here and should not be changed for an inverter. This value is used for communication with the data logger and Smart-Meter.

1. Select < Select Inverter >.

2. Click on the icon to go to the next screen

3. If necessary, enter a **new** value for **each** additional inverter that follows the first Communication device and <Confirm> after entering.

» Modbus address configured.

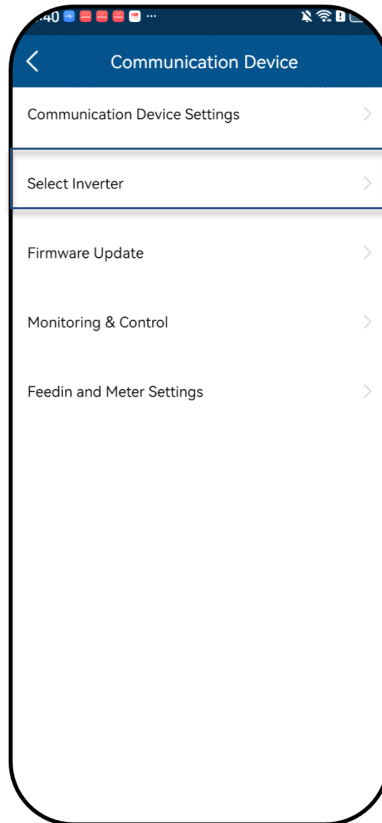

Fig. 99. Select inverter

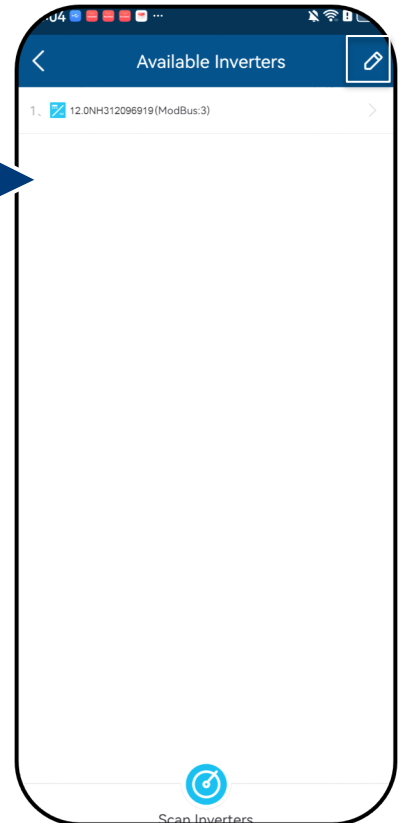

Fig. 100. click symbol



Fig. 101. View Modbus address

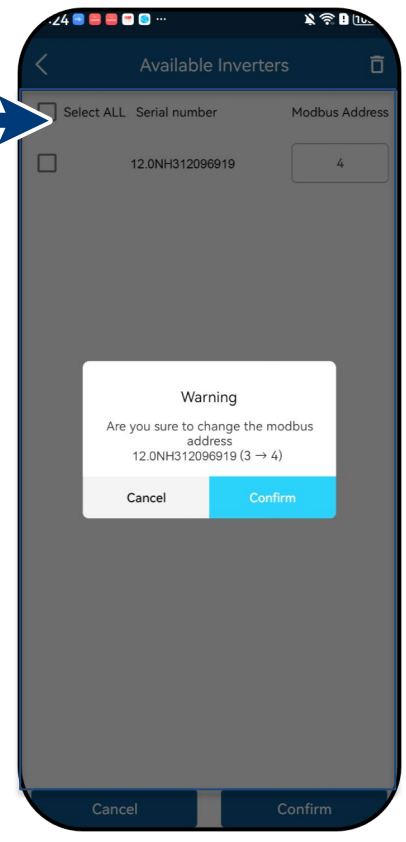

Fig. 102. Modify Modbus address

9.7.7 Monitoring and control

↻ The Communication Device is registered on the customer’s WLAN network and the router is connected to the internet.

↻ <Communication Device> menu is open.

Note: The device supports Modbus/TCP and conventional SunSpec models. If there are concerns over security, write access can be deactivated via the SunSpec Register.
The signal is transmitted via an installed RS485 line.

1. Select <Mode>. menu under <Monitoring & Control >.

- <KACO blueplanet smartcloud>: data from connected devices is uploaded to the KACO cloud server for evaluation.

- <Modbus TCP IP Server>: By default, the Communication Device receives the Modbus TCP or SunSpec commands and a connected data logger responds to them.

- <APP (local)>: local operation mode without further communication. (Standard)

2. Confirm the selection with <Confirm>.

Note: After successful configuration, the collector will restart and the page will return to the APP home page.

» Operation mode set.

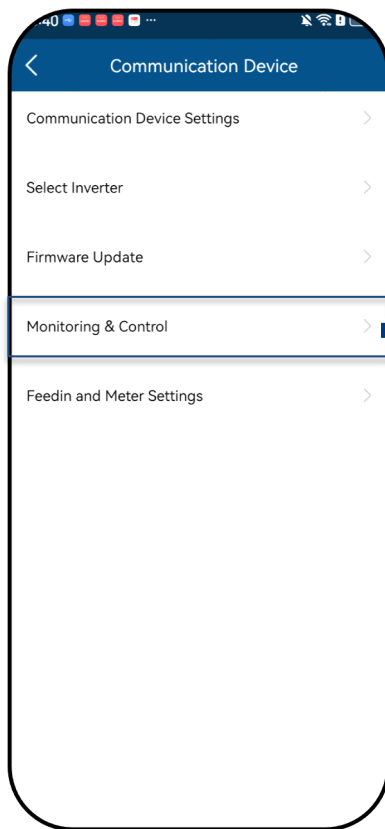

Fig. 103. Select monitoring & control



Fig. 104. Select mode

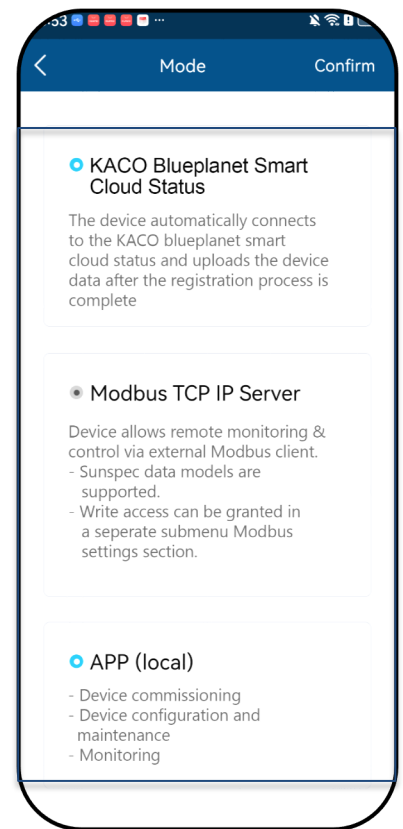

Fig. 105. Set mode

9.7.8 Web portal data transmission interval

Note: The interval of the data upload determines the timeliness of the data presented in the data logger monitor.

↻ < Communication Device > menu is open.

1. Select < Monitoring & Control >.

1. Select < Cloud Selection >.

2. Select upload interval.

3. Save settings with <Confirm>

» Interval set.

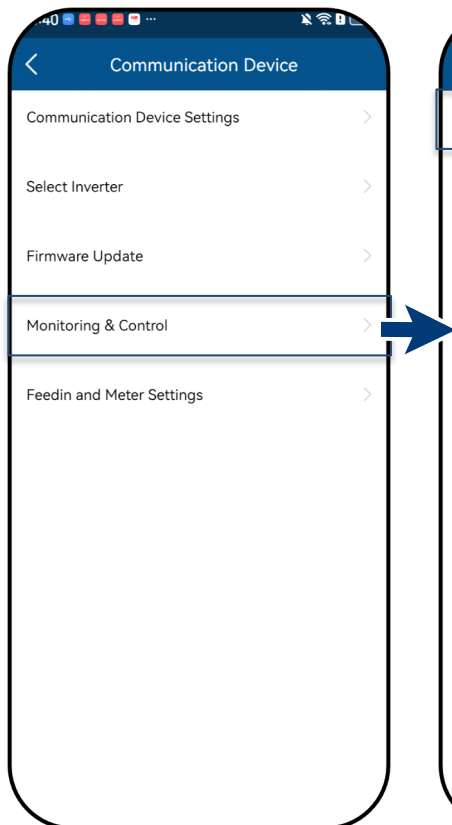

Fig. 106. Select monitoring & control

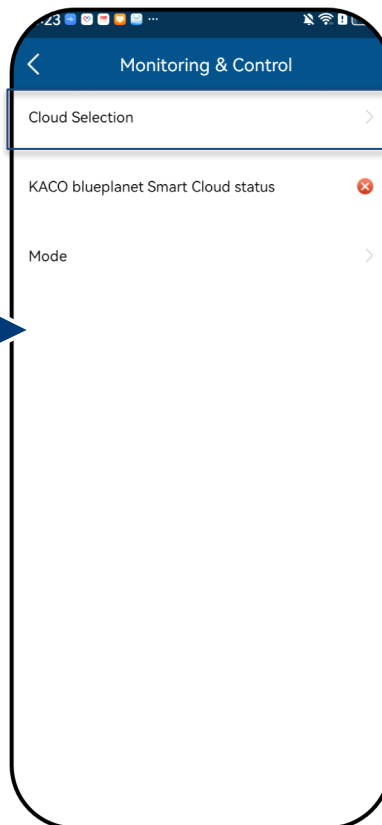

Fig. 107. Set data transmission interval (web portal)

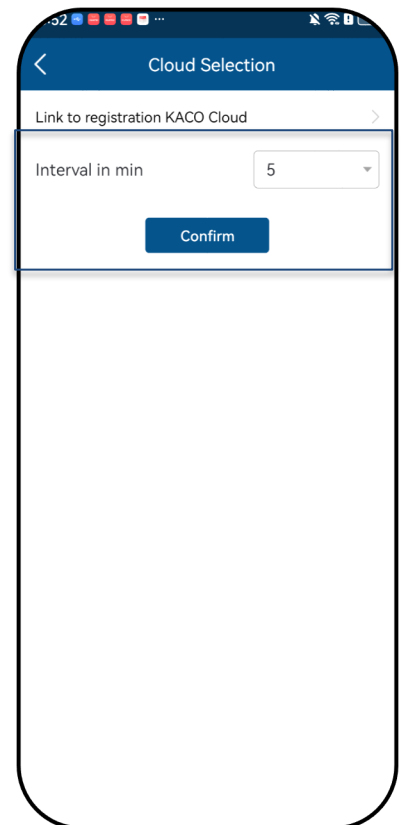

Fig. 108. Confirm interval

9.7.9 Dynamic feed-in

<Communication Device > menu opened.

The connection shown in the block diagram Fig. 111 has been established.

Note: For more information, see Chapter 9.12 on page 98

1. Click the <Feedin and Meter Settings> menu.

2. Switch on <Enable Feedin Control> when the meter is connected.

3. Select meter model >> SDM 630CT.

Note: select correct type:

- SDM630CT - RS485 + Modbus RTU
- SDM630DT – user-programmable with RS485 + S0 output

4. Switch on <Enable Meter Data Processing> when the meter is connected.

5. Switch on < Fail safe enable> when the meter is connected.

Note: The export active power will continually be limited to the right value during the failure of one or more its components or the failure of any communications between the controller and devices.

6. At <Maximum Feedin Power>, set the maximum power which the device may feed into the grid.

Note: This setting is only possible if the Meter model is connected to the device.

6. Start the function with <Confirm>.

7. Please remedy if these conditions are not met. See Chapter 9.12 on page 98.

» Dynamic feed-in is selected.

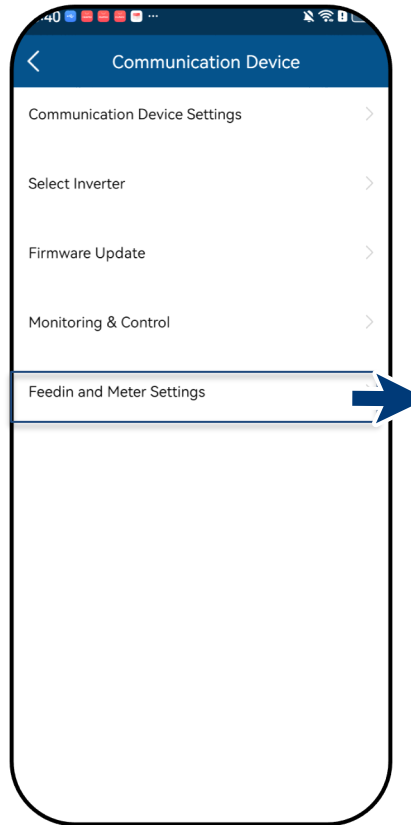

Fig. 109. Select feedin and meter settings

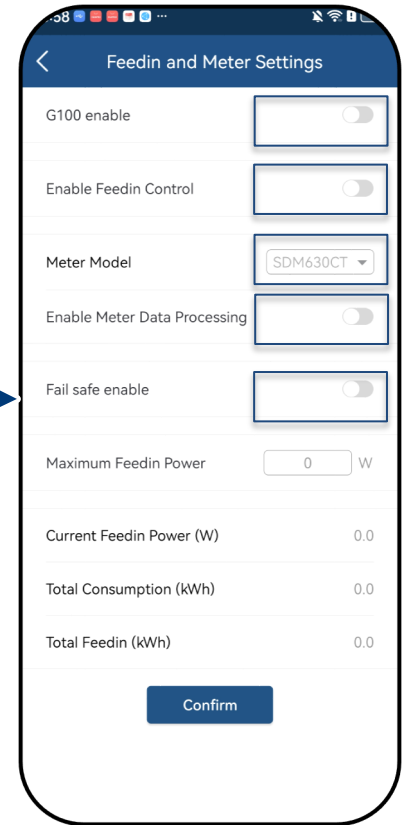

Fig. 110. Select smart meter model and set max. feed-in power

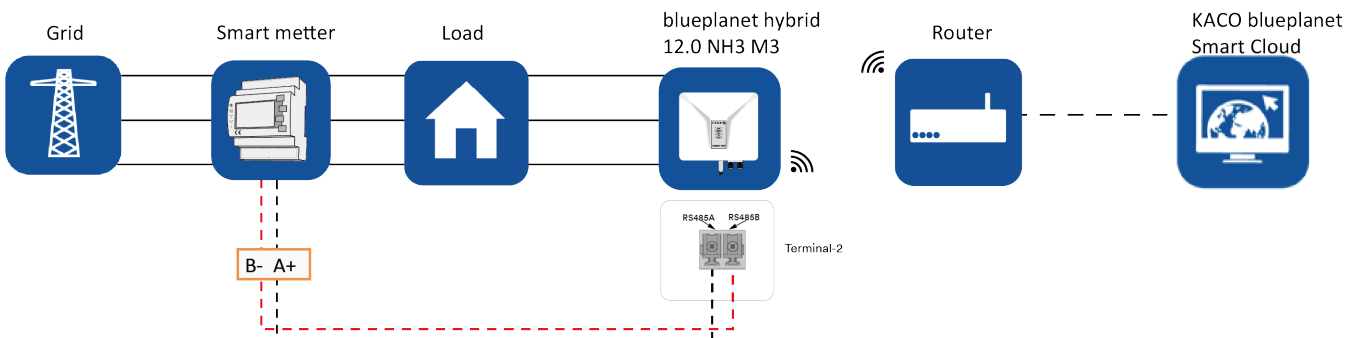

Fig. 111. Block diagram for dynamic feed-in when select SDM630CT

9.8 Menu of Inverter

9.8.1 Viewing the Instantaneous Values

🔄 The required device is selected in <Available inverters> and the <Inverter Details & settings> menu is opened.

1. Select <Instantaneous Values> and view information about the installation.

Note: All measured values for your PV system and the grid power and battery are displayed. In addition, after solar feed-in, the daily values and yields are displayed.

Note: The measured values are only displayed for the selected device. A simultaneous evaluation of all inverters can only be carried out via our “KACO blueplanet smartcloud” monitoring portal.

2. You can view the current status of the inverter

3. View current Power and Power Factor.

4. View pending errors via <Error Code> and <Error Detail>. N/A = no error

Note: In the event of a pending error, note the Error code list in chapter 10.5 on page 102.

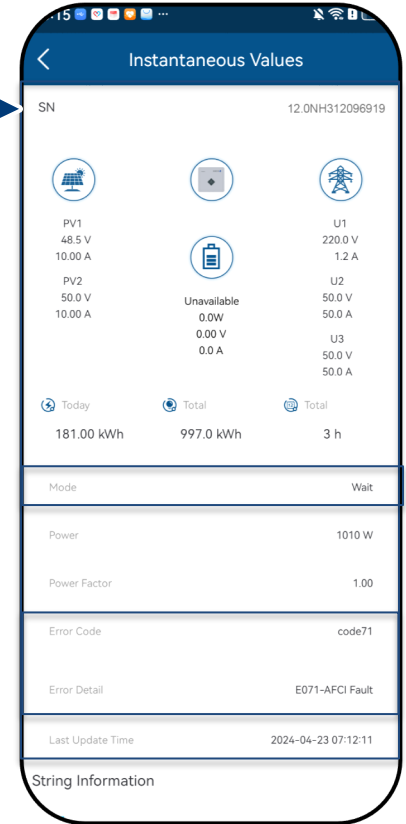
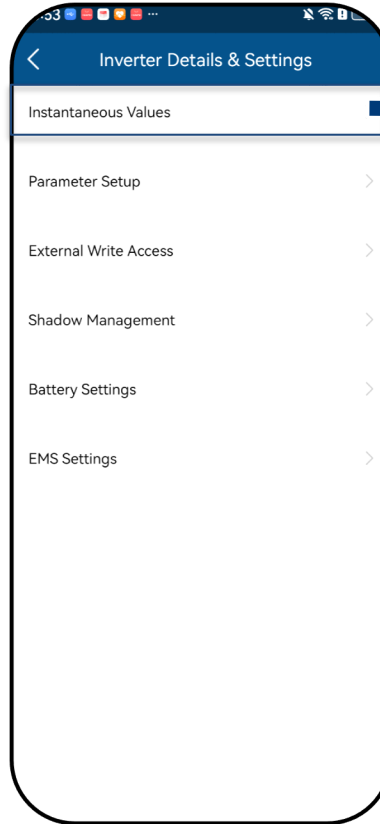

Fig. 112. Viewing the live values

Fig. 113. Overview of power values

9.8.2 Authorisation to change parameters

⌂ < Inverter Details & Settings > menu has been opened from <Available Communication Device > and <Find inverter>.

1. Open < Parameter Setup > to set the parameters for initial start-up.

Important: No password is required for **initial parameter setting**.

A password must be entered if it becomes necessary to change the parameters of the device after initial start-up (security function). The specific password for the inverter must be requested from KACO Service.

2. Enter the password in the <Password> field and confirm with <Confirm>.

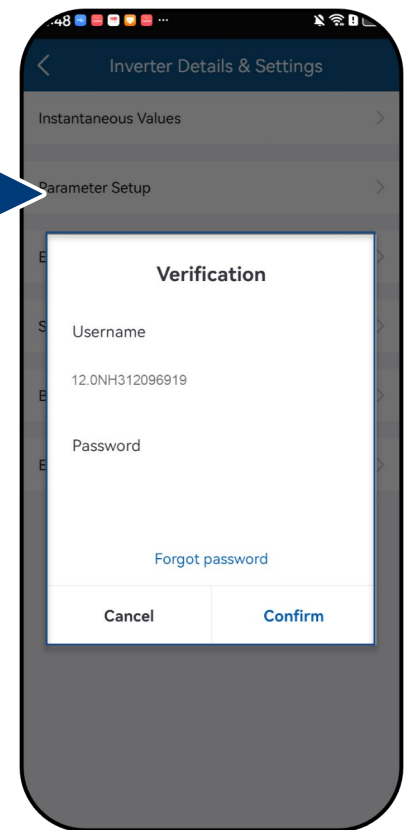
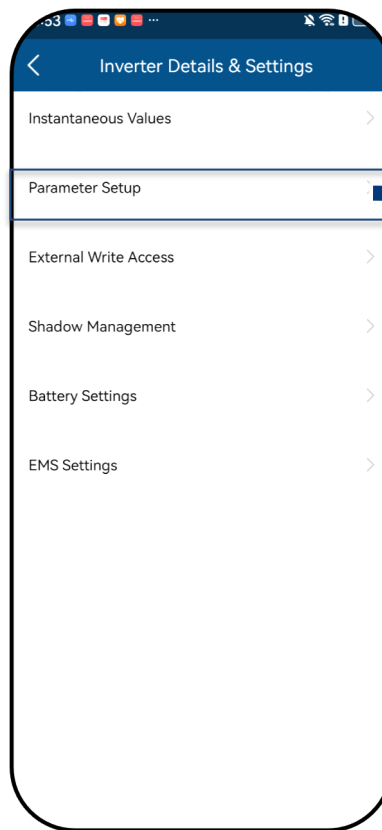
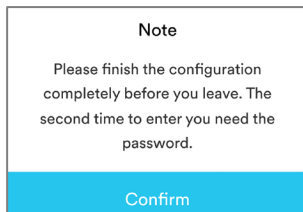

Fig. 114. Warning issued only on the **first** accidental abort attempt.

Fig. 115. Select parameter setup

Fig. 116. Authorisation required

9.8.3 Password Recovery

⌂ A pop-up window will appear, prompting you to enter your initial password.

Note: If the entry is incorrect, please contact the KACO customer service team.

1. Select <Instantaneous Values> and view information about the installation.

2. Confirm the option <**Forgot Password**>. A new pop-up window will open.

3. Contact KACO customer service. The customer service team will provide you with a **device-specific password**.

4. Record the device-specific password and enter it into the <**Password**> field.

5. Immediately set a new password by entering it into the <**New Password**> field.

6. Confirm the new password by re-entering it into the <**Confirm Password**> field.

» You can continue to adjust the parameters using the new password.

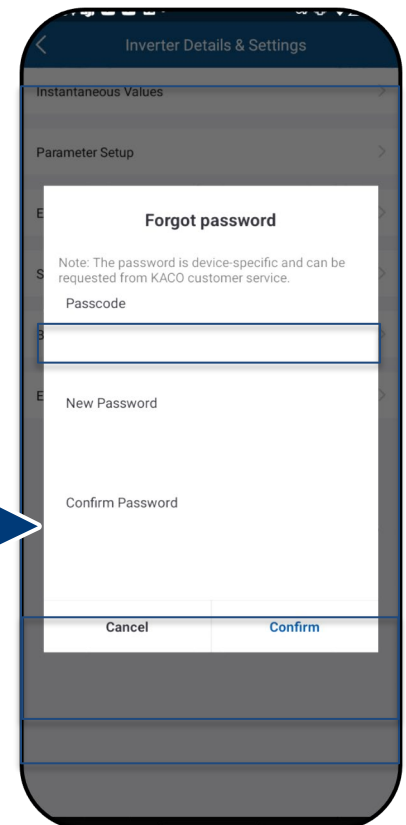
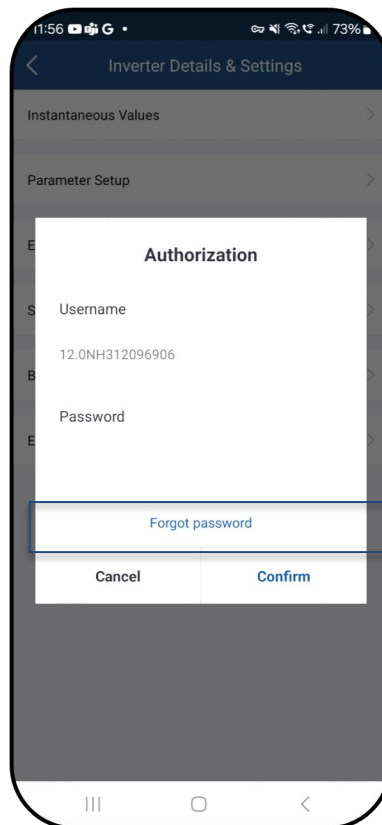

Fig. 117. *Forgot password?*

Fig. 118. *Password Recovery*

9.8.4 Enabling external write access

🔄 You have the option of granting write access for external protocols. Access relates exclusively to the “Monitoring & control” menu. See Chapter 9.7.7

Note: By default, the function is disabled. After activation, take note of the information field in the window that appears.

1. Input the password.

Note: If you forget your password. Passcode is serial number specific and can be requested at KACO new energy Customer Service.

2. If required, grant write access by pressing <Confirm>.

» External write access granted via SunSpec / KACO legacy protocol.

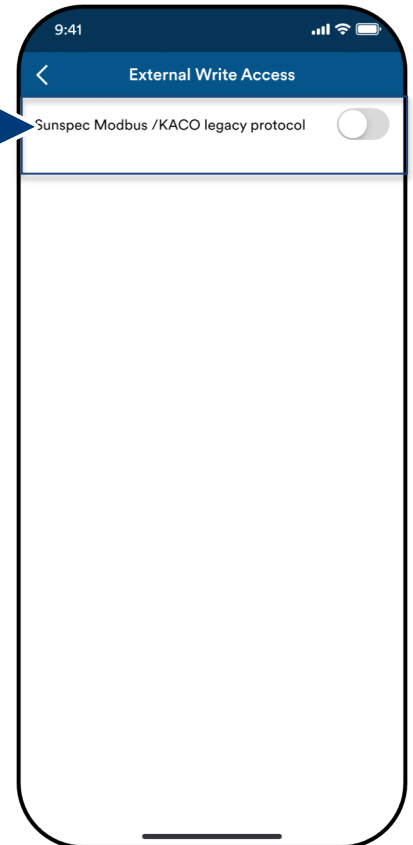
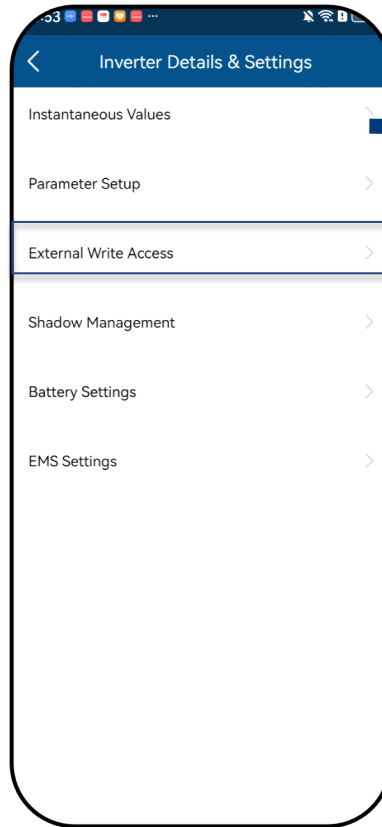
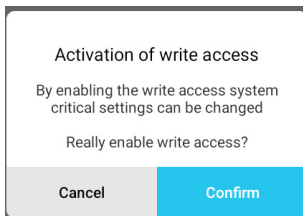

Fig. 119. Grant access to device via SunSpec Modbus / Kaco legacy protocol

Fig. 120. Select external write access Fig. 121. Activation function

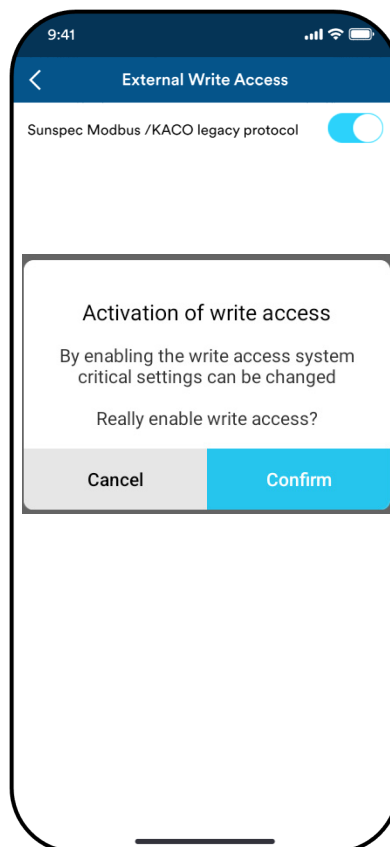
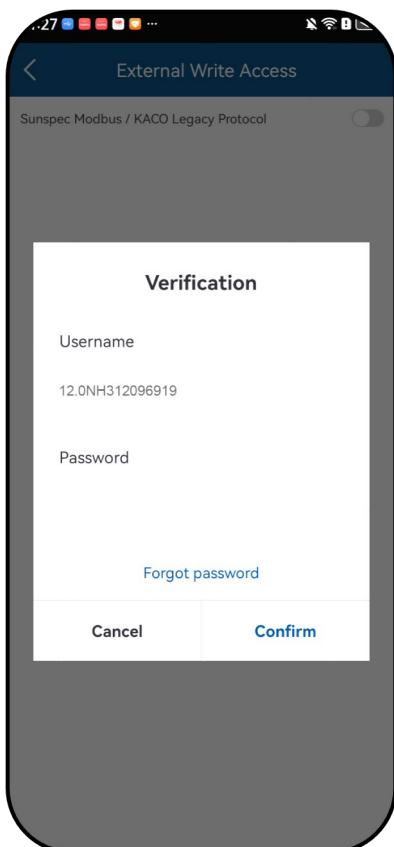

Fig. 122. Enter a password

Fig. 123. Confirm activation of external write access

9.8.5 Shadow Management

🔄 The desired device is selected under <Available Inverters> and the <Inverter Details & Settings> menu is opened.

Note: Enables optimized MPP tracking for PV module shadow management. After the function is activated, each PV channel is scanned at a 10-minute interval. Captures and tracks the maximum power point voltage when the output power is not limited and the input power of this channel is not overdriven.

1. Select < Shadow Management>.

2. In case of partial shading of a PV module, activate <shadow management> to generate additional MPP tracking points.

» Shadow management configured.

Note: Depending on the overall design of the PV system and the use of additional module optimizers, activated shade management may adversely affect tracking. **This is not a malfunction.**

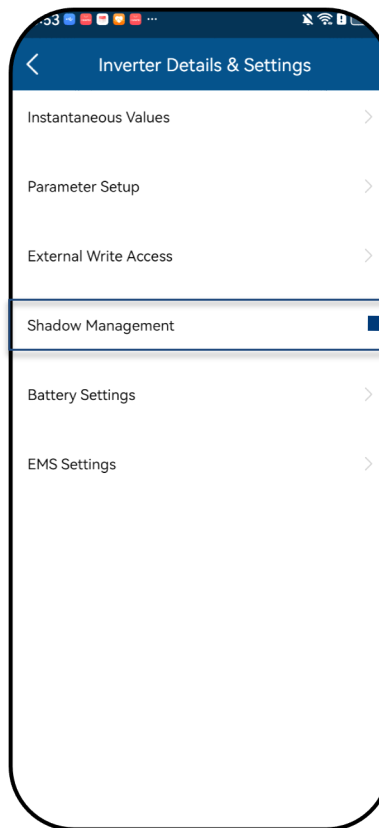

Fig. 124. Select shadow management

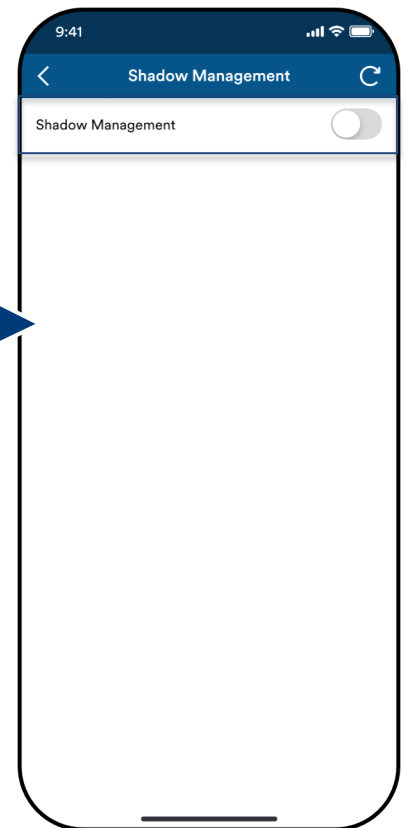

Fig. 125. Activate shadow management

9.8.6 Battery Settings

🔄 The desired device is selected under <Available Inverters> and the <Inverter Details & Settings> menu is opened.

1. Select < Battery Settings>.

2. Select Battery Type.

3. Set < Battery charge maximum>.

4. Set < Battery discharge minimum>.

5. Enter the number of battery modules

6. Save settings with <Confirm>

» Battery configured.

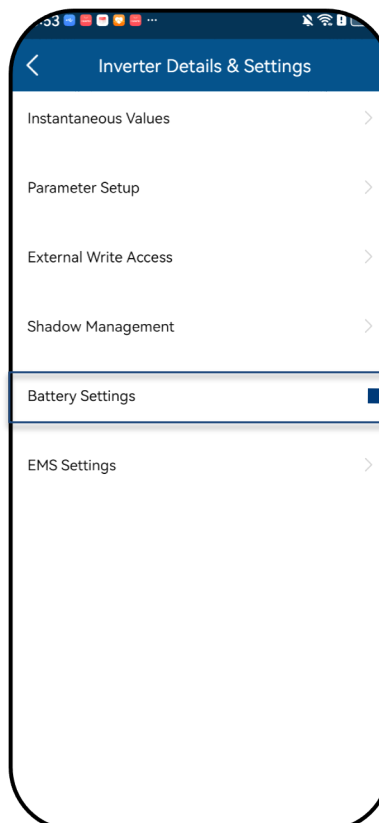

Fig. 126. Select Battery Settings

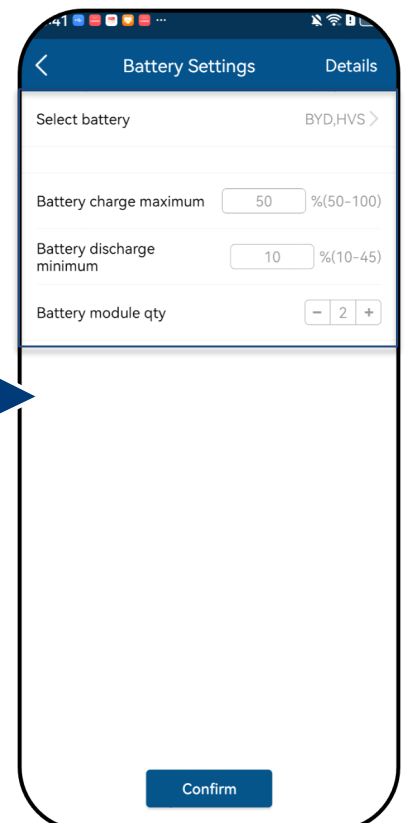

Fig. 127. Setting battery parameters

9.8.7 Ems Settings

1. Select < Ems Settings >.
2. Activate the <UPS > button and **select** the working mode.

Note: UPS: Fast detection for grid fault, supporting 10ms switch time.
EPS: Normal detection for grid fault, supporting LVRT function.

Note: Self-consumption mode
 The photovoltaic energy is preferentially used by local load to improve the self-consumption rate and self-sufficiency rate.

Reserve energy mode
 The battery is a back-up energy storage device. The battery always charged by PV power if it is not full charged. The battery discharge only when the utility grid loss.

Custom mode (see 9.9.8)
Off-grid mode
 If the power grid is too weak and the inverter operating unstably, it is recommended that the customer switch to off grid mode to achieve stable power supply. For more information, please refer to Chapter 3.2

» EMS configured.

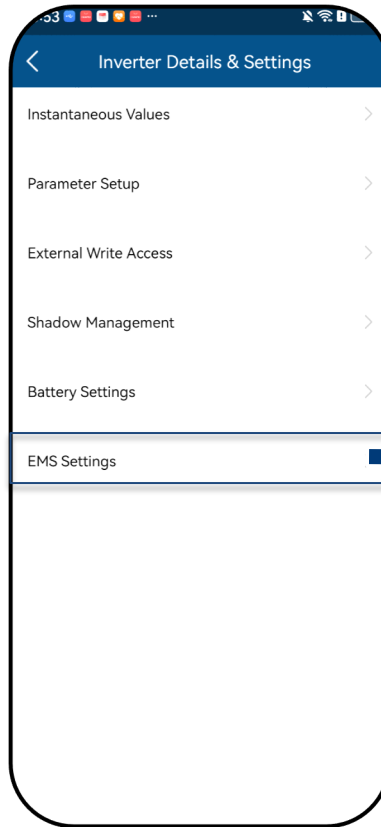

Fig. 128. Select Ems Settings

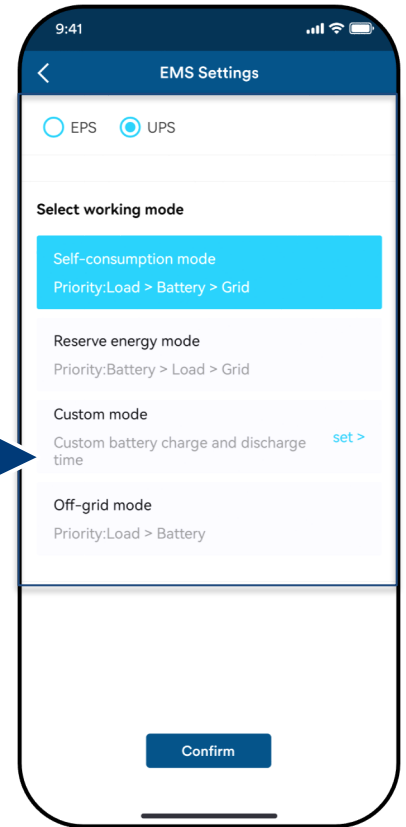

Fig. 129. Setting working mode

9.8.8 Custom mode

In custom mode, you can configure your own charging and discharging times. You can also define the charging and discharging power.

1. Enter the <charging power> in Wh with which the battery is charged.
2. Enter the <discharging power> in Wh with which the battery is discharged.
3. Select <copy> to transfer the set charging/discharging times from one day to another weekday.

Note:
UPS: Fast detection for grid fault, supporting 10ms switch time.
EPS: Normal detection for grid fault, supporting LVRT function.

» Adjust the charging/discharging schedule if necessary.

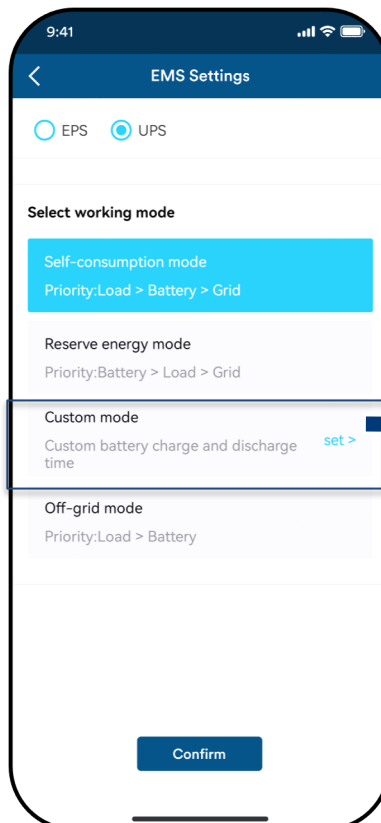

Fig. 130. Select Custom Mode

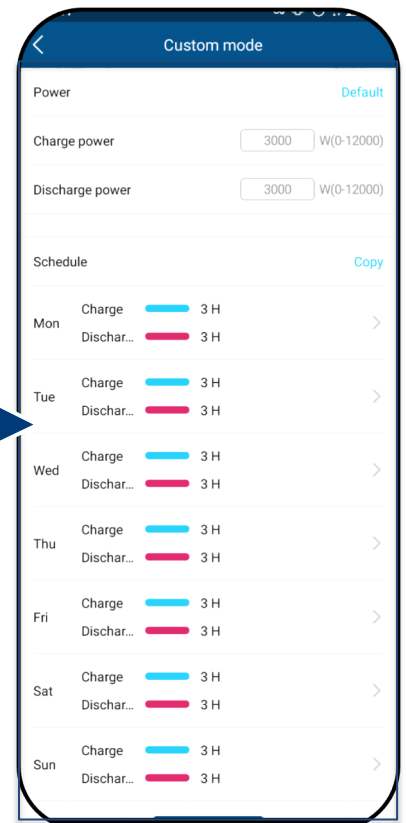

Fig. 131. Set Charging & Discharging Power

In the schedule, the charging/discharging times are set.

1. Select the weekday.
2. Set the charging times to best store the excess PV power.
3. Set the discharging time to best utilize the stored energy in the evening.

Note:
Additional time windows can be defined for a day if necessary.

» Ems configured.

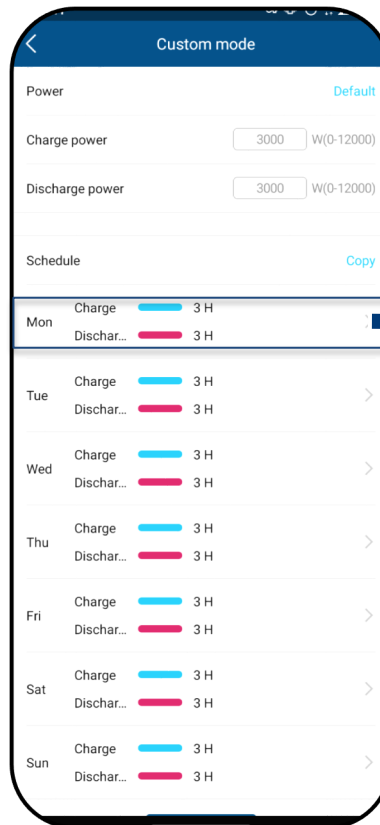

Fig. 132. Select the Weekday

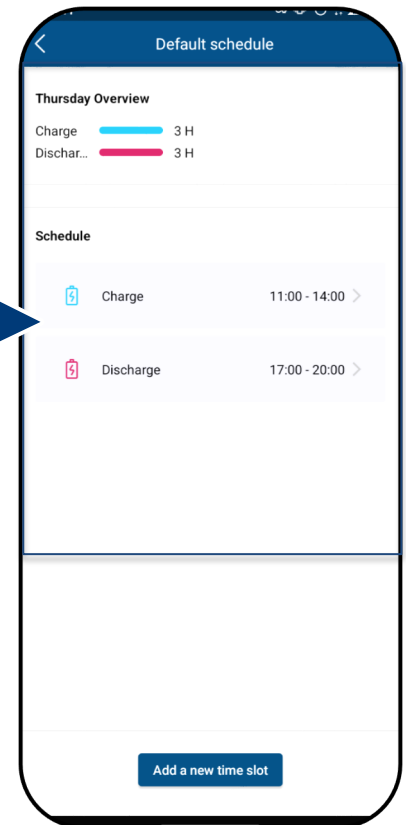

Fig. 133. Set the Standard Schedule

9.9 Inverter parameter settings

9.9.1 Selecting country and grid type

The required device is selected in <Available inverters> and the <Settings for> menu is opened in the <Parameter settings> in the <Inverter details & settings> menu.

1. Select <Country / Grid code>.

Caution: The following settings can only be made once without a password during initial start-up!

2. Select the operator country and grid type in the field according to the grid operator requirements and confirm with <Confirm>.

Note: By default, all required parameters are activated via the relevant grid code.

Note: When the grid standard has been changed, the device carries out a self-test. As a result, around 2 minutes may elapse before the device feeds in again.

Note: Further grid standards settings can be made if requested by the grid operator or customer (e.g. setting for reactive power, Q(U) curve, see Chapter 9.9.2).

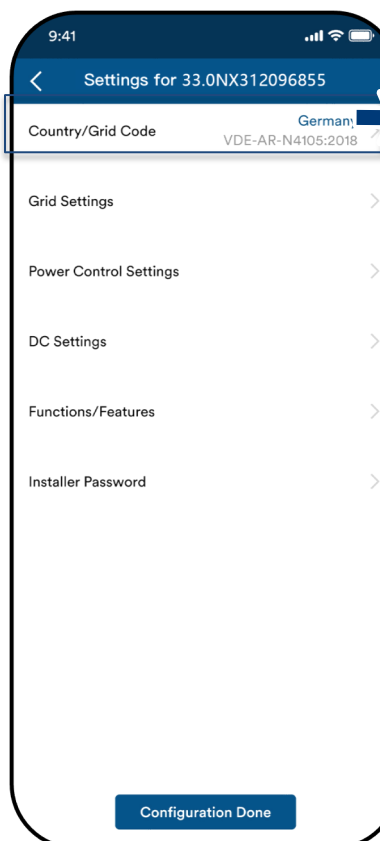

Fig. 134. Check or change country and grid-type

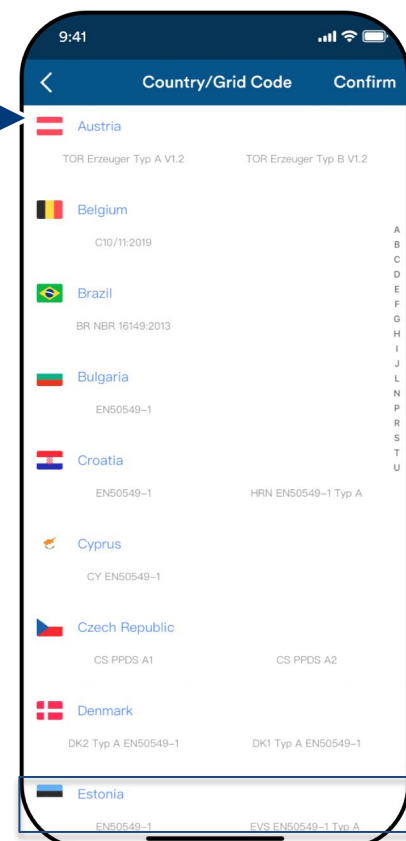

Fig. 135. Select country & grid code

9.9.2 Voltage shutdown settings

Note: There are three thresholds for overvoltage and undervoltage protection. The first threshold value indicates the lower range. The middle threshold range is freely adjustable. The third threshold value indicates the upper range.

↻ The <Settings for> menu is opened.

1. Select < Grid Settings > to go to the next screen.

2. Select < Trip Settings >

3. Select < Trip Voltage Settings >

4. Set min. and max. shutdown time with associated voltage for each phase.

Principle:

- Trip Overvoltage Level 1 ≤ Trip Overvoltage Level 2 ≤ Trip Overvoltage Level 3
- Trip UnderVoltage Level 1 ≥ Trip UnderVoltage Level 2 ≥ Trip UnderVoltage Level 3
- Trip Time Level 1 ≤ Trip Time Level 2 ≤ Trip Time Level 3

3. Confirm the settings with the <Confirm> button.

» Voltage protection defined.

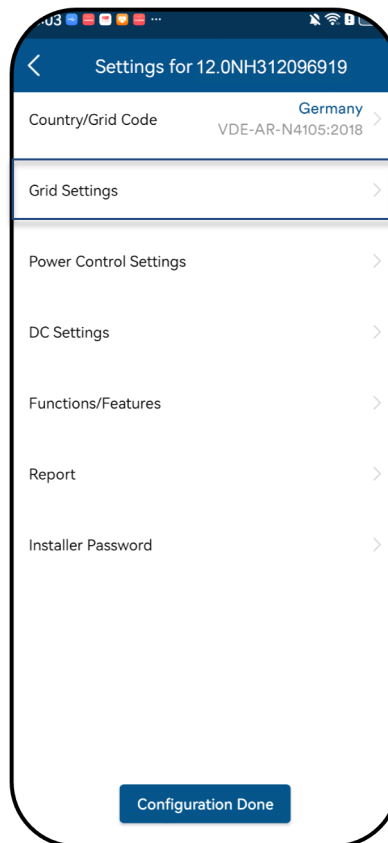

Fig. 136. Select grid settings

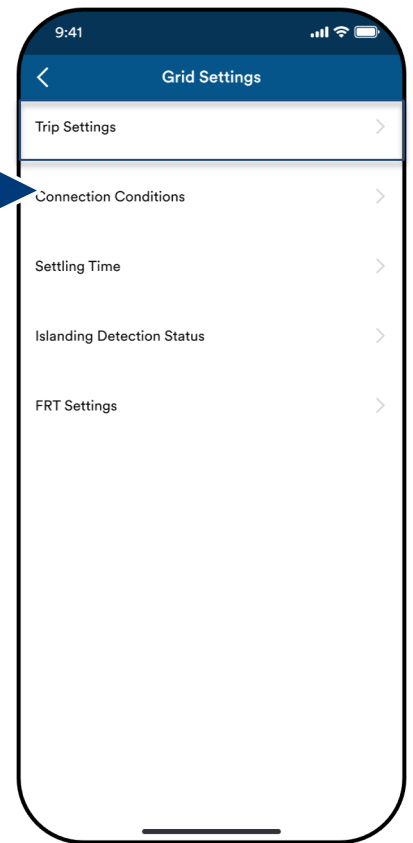

Fig. 137. Select trip settings



Fig. 138. Select trip voltage settings

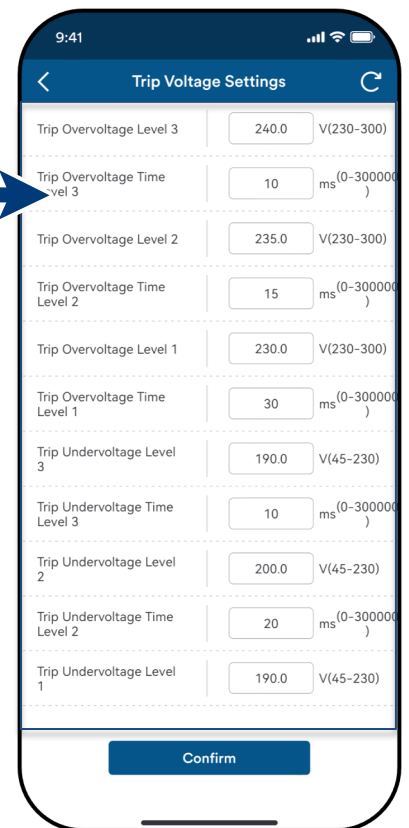

Fig. 139. Define voltage range and shutdown times

9.9.3 Frequency shutdown settings

Note: There are three thresholds for overfrequency and underfrequency protection. The first threshold value indicates the lower range. The middle threshold range is freely adjustable. The third threshold value indicates the upper range.

↻ The <Settings for> menu is opened.

1. Select < Grid Settings > to go to the next screen.

2. Select < Trip Settings >

3. Select < Trip Frequency Settings >

4. Set the thresholds.

Principle:

- Trip Overfrequency Level 1 ≤ Trip Overfrequency Level 2 ≤ Trip Overfrequency Level 3
- Trip Underfrequency Level 1 ≥ Trip Underfrequency Level 2 ≥ Trip Underfrequency Level 3
- Trip Time Level 1 ≤ Trip Time Level 2 ≤ Trip Time Level 3

3. Save settings with <Confirm>.

» Frequency protection defined.

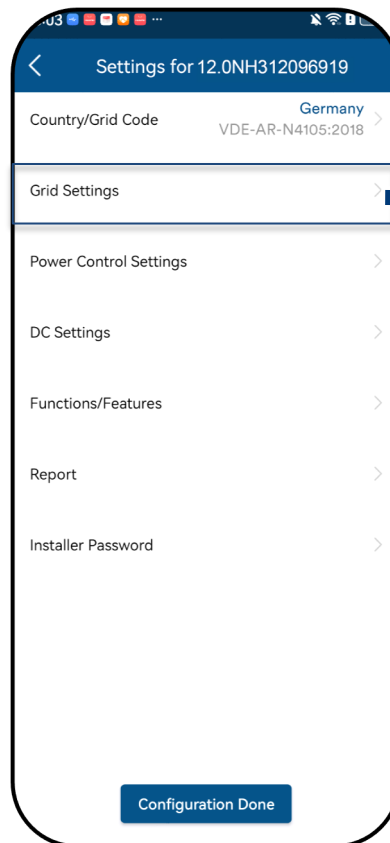

Fig. 140. Select grid settings

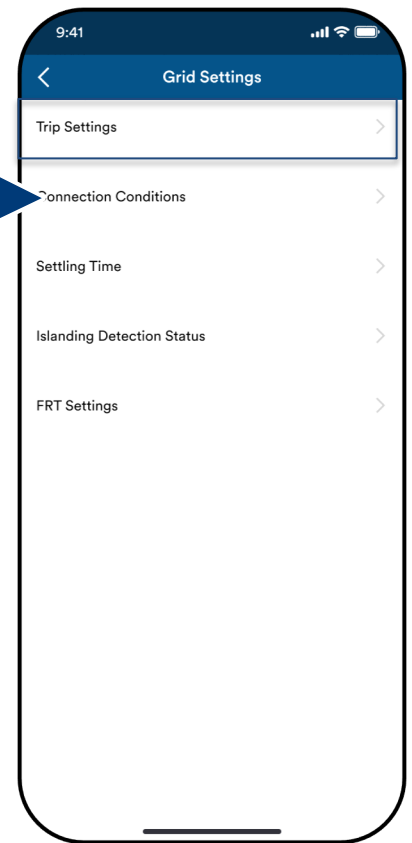

Fig. 141. Select trip settings



Fig. 142. Select trip frequency settings



Fig. 143. Set frequency range and ROCOF protection limit

9.9.4 Connection time settings

Note: Set monitoring time when one of the voltage and frequency values has been changed. If the measured values are within the range defined by the selected grid standard, the inverter can start or reconnect.

↻ The <Settings for> menu is opened.

1. Select < Grid Settings > to go to the next screen.
 2. Select < Connection Conditions >
 3. Select < Time Settings >
 4. Set <Start Connect Time>
 5. Set <Reconnection time>.
 6. <Confirm> settings.
- » Connection time defined.

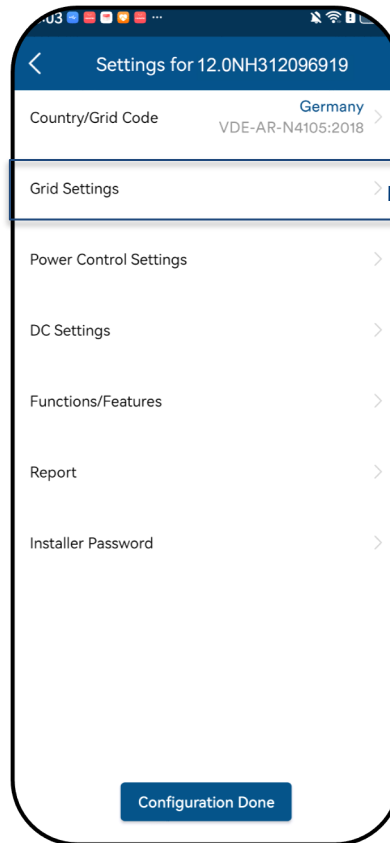

Fig. 144. Select grid settings

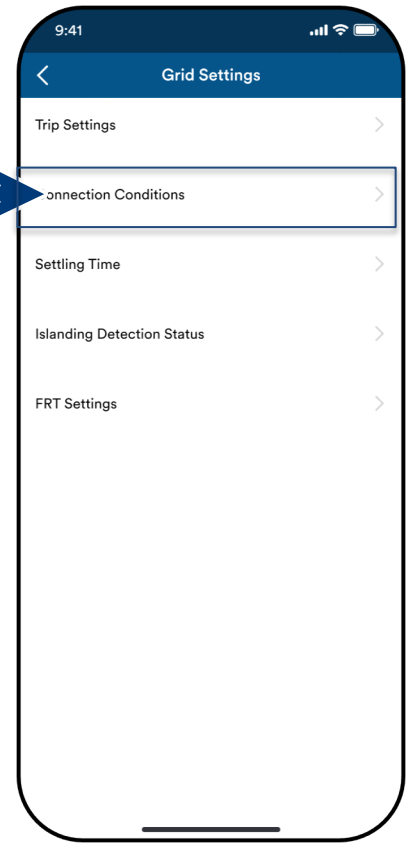

Fig. 145. Select connection conditions

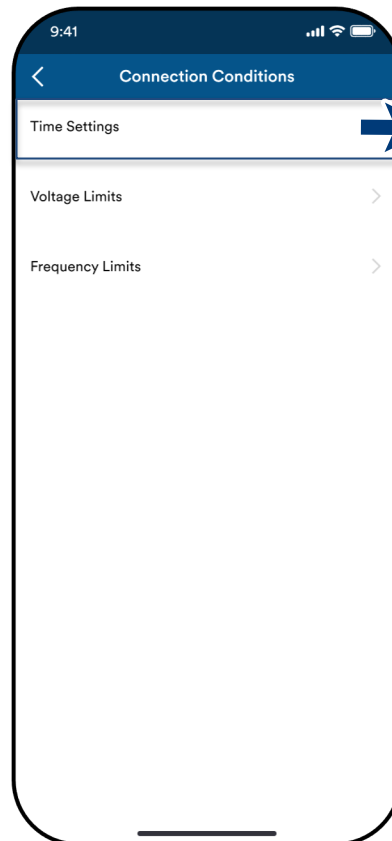

Fig. 146. Select time settings

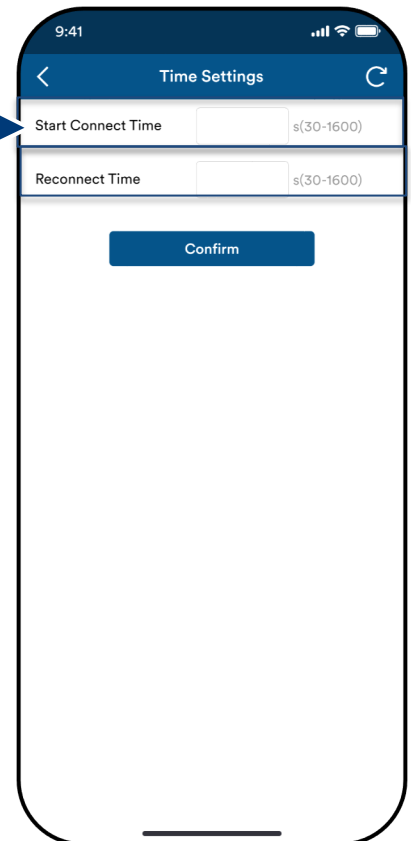

Fig. 147. Set frequency range and ROCOF protection limit

9.9.5 Connection voltage limits settings

Note: The appropriate voltage range for starting can be set according to the requirements of the local grid company.

🔄 The <Settings for> menu is opened.

1. Select < Grid Settings > to go to the next screen.

2. Select < Connection Conditions >

3. Select < Voltage Limits >

4. Set <Max.& Min Voltage >.

5. <Confirm> settings.

» Connection voltage defined.

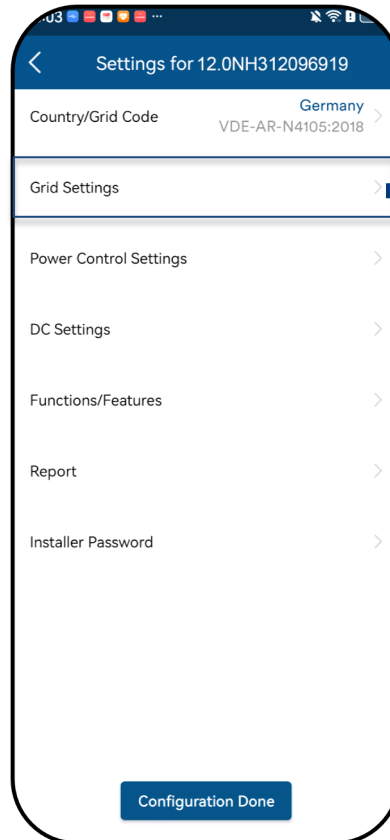

Fig. 148. Select grid settings

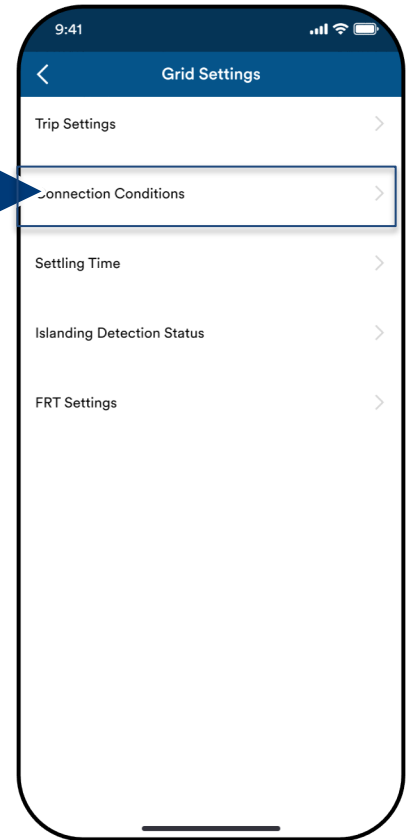

Fig. 149. Select connection conditions

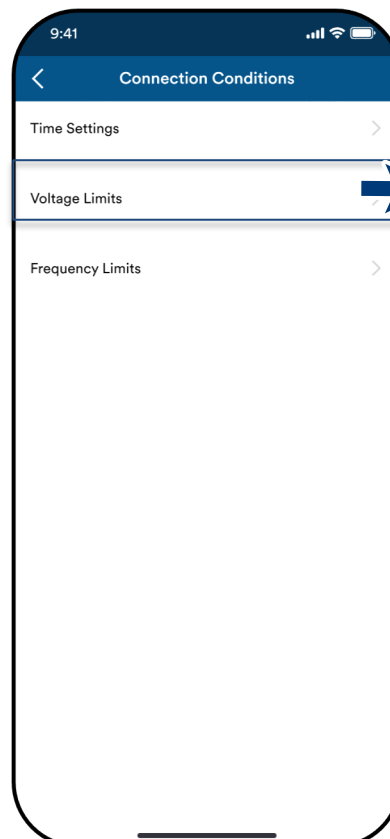

Fig. 150. Select voltage limits

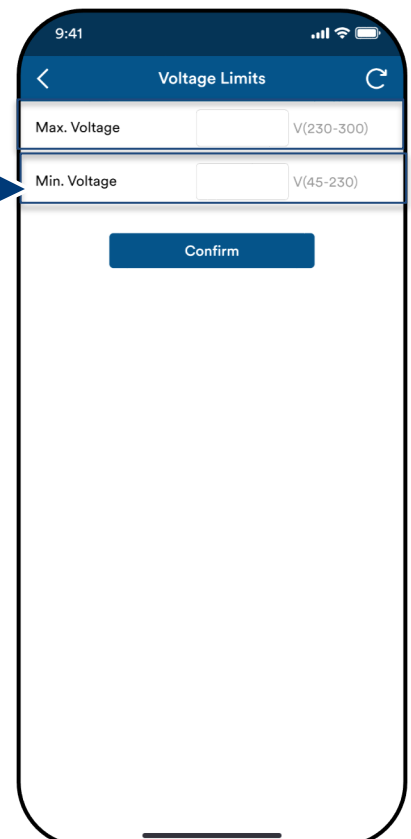

Fig. 151. Set voltage value

9.9.6 Connection frequency limits settings

Note: The appropriate frequency range for starting can be set according to the requirements of the local grid company.

🔄 The <Settings for> menu is opened.

1. Select < Grid Settings > to go to the next screen.

2. Select < Connection Conditions >

3. Select < Frequency Limits >

4. Set <Max.& Min Frequency >.

5. <Confirm> settings.

» Connection frequency defined.

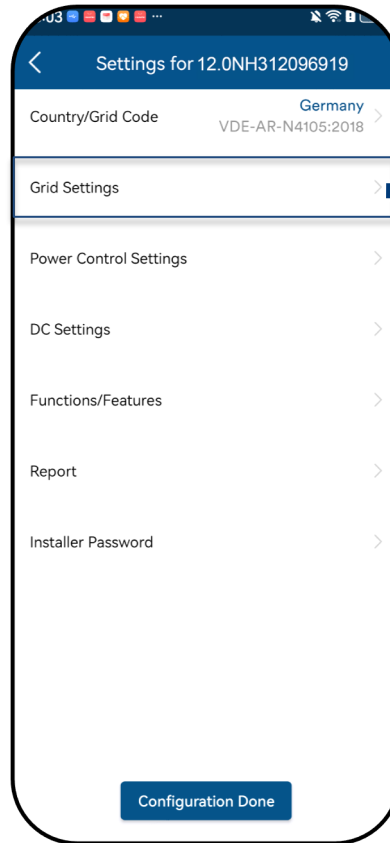

Fig. 152. Select grid settings

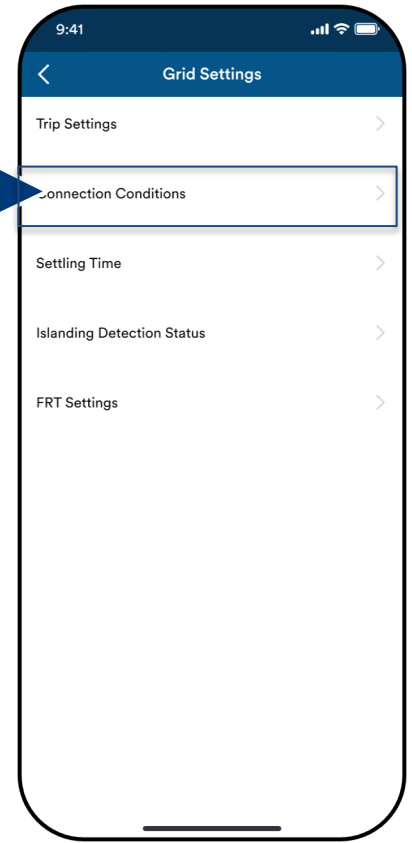

Fig. 153. Select connection conditions

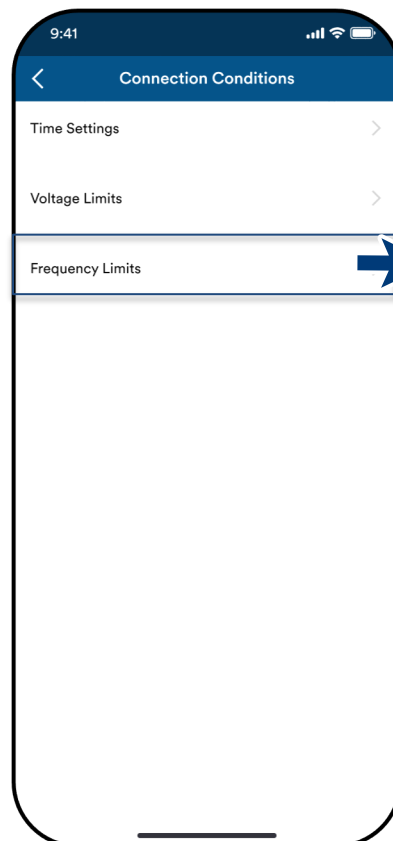

Fig. 154. Select frequency limits

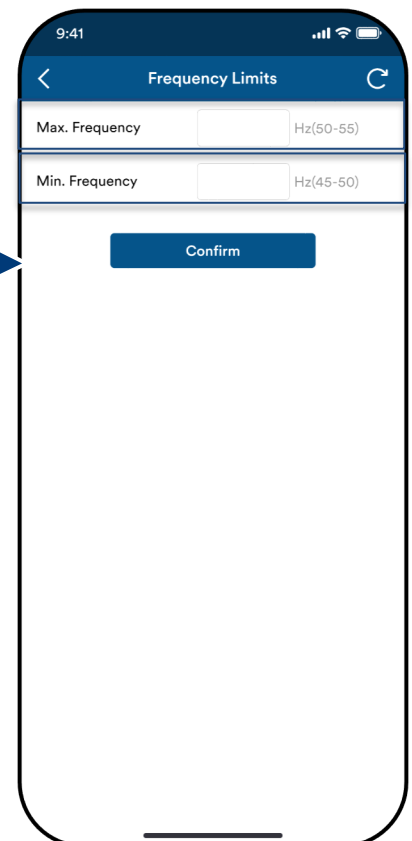

Fig. 155. Set frequency value

9.9.7 Active power settling time

Note: The dynamics of the P(U) control shall correspond with a first-order filter with a configurable time constant between 3 s and 60 s for some country code, e.g. Austria. That means 95% of a new setpoint must be achieved within three times the time constant. The active power settling time is defined as three times the time constant.

🔄 The <Settings for> menu is opened.

1. Select < Grid Settings > to go to the next screen.

2. Select < Settling Time >

3. Select < Active Power Settling Time >

4. Set < Active Power Settling Time >

5. <Confirm> settings.

» Active power settling time defined.

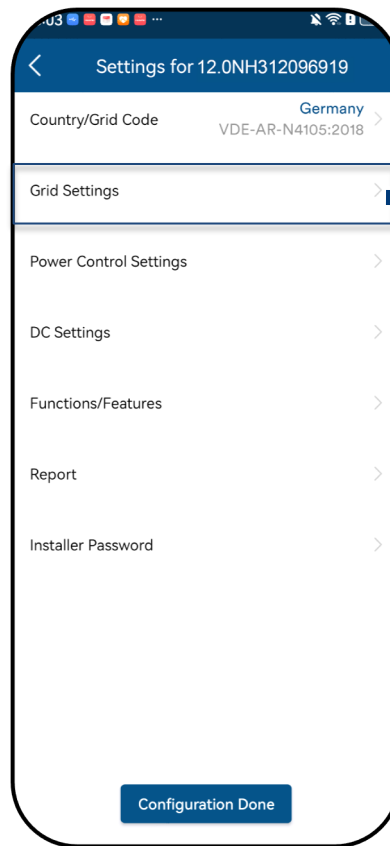

Fig. 156. Select grid settings

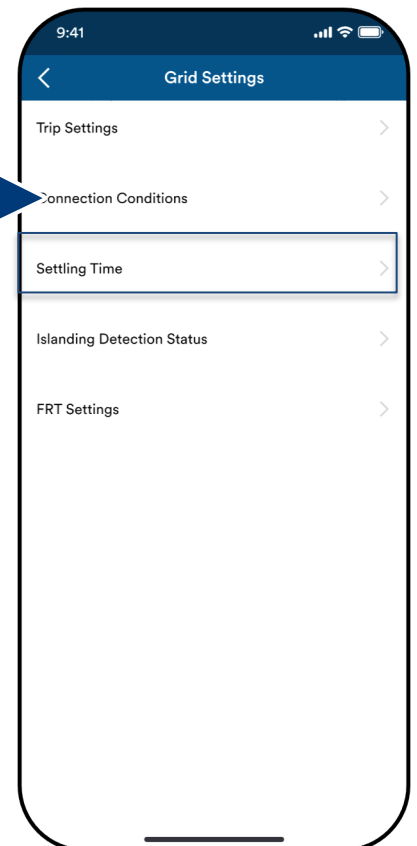

Fig. 157. Select settling time



Fig. 158. Select active power settling time

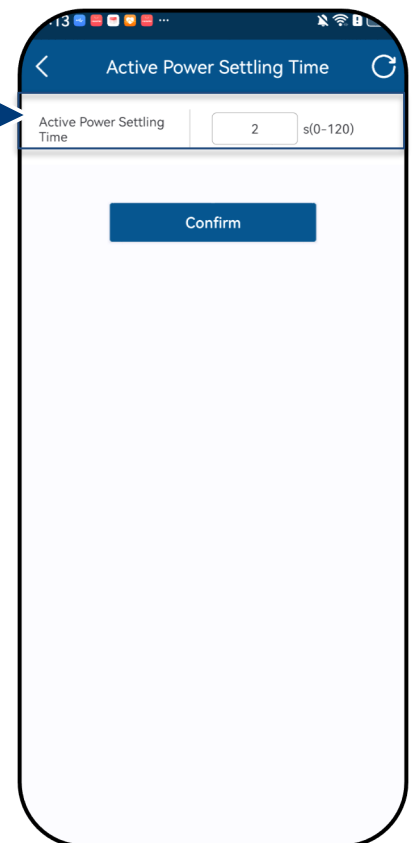

Fig. 159. Set time

9.9.8 Reactive power settling time

Note: The dynamics of the reactive power control shall correspond with a first-order filter with a configurable time constant between 3 s and 60 s. That means 95% of a new setpoint must be achieved within three times the time constant. The reactive power settling time is defined as three times the time constant.

🔄 The <Settings for> menu is opened.

1. Select < Grid Settings > to go to the next screen.

2. Select < Settling Time >

3. Select < Reactive Power Settling Time >

4. Set <Reactive Power Settling Time>.

5. <Confirm> settings.

» Reactive power settling time defined.

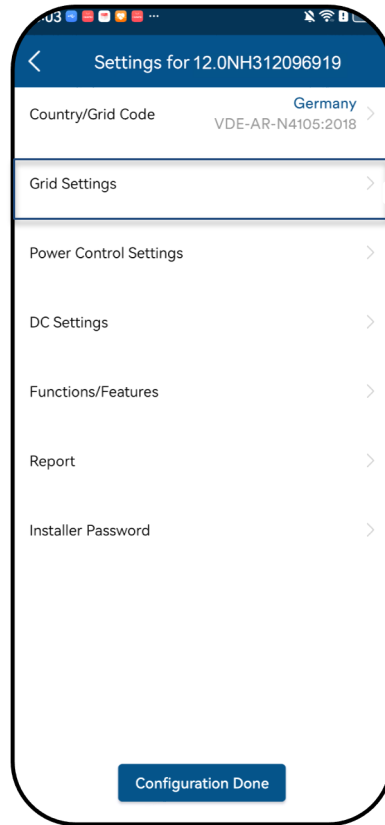

Fig. 160. Select grid settings

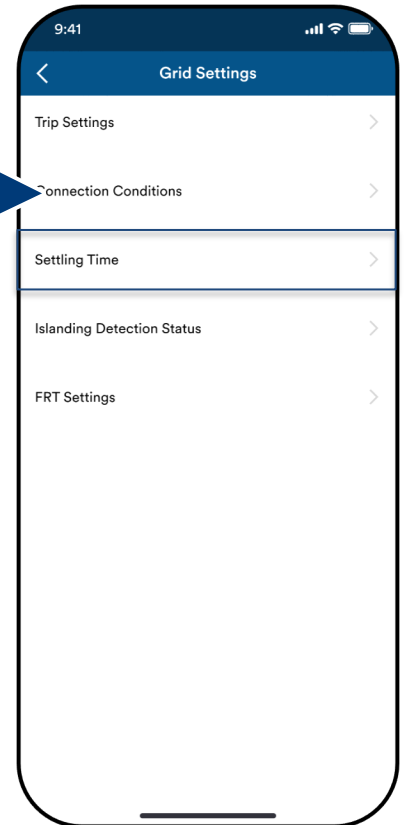

Fig. 161. Select settling time



Fig. 162. Select reactive power settling

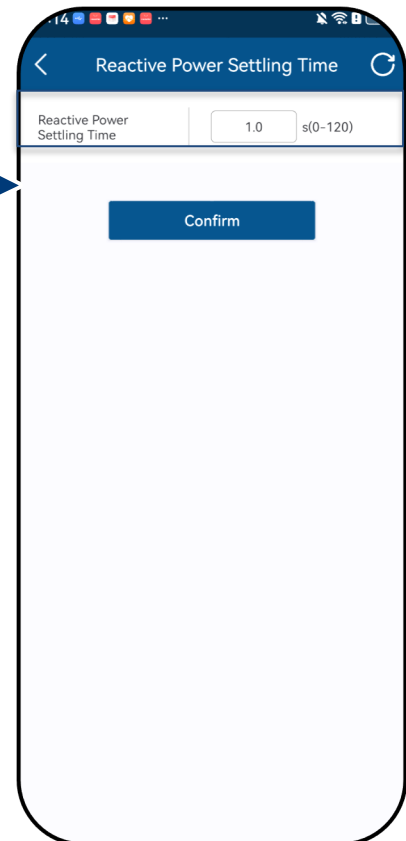

Fig. 163. Set time

9.9.9 Islanding Detection Status

🔄 The <Settings for> menu is opened.

1. Select < Grid Settings > to go to the next screen.

2. Select < Islanding Detection Status >

3. Activate < Islanding Detection Status >

5. <Confirm> settings.

» Islanding detection activated.

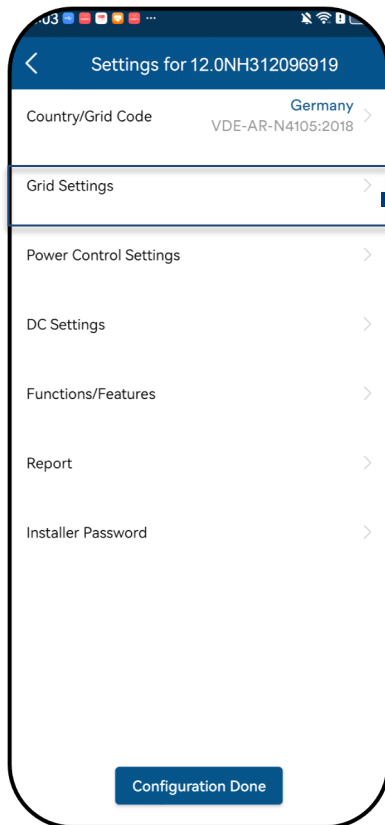

Fig. 164. Select grid settings

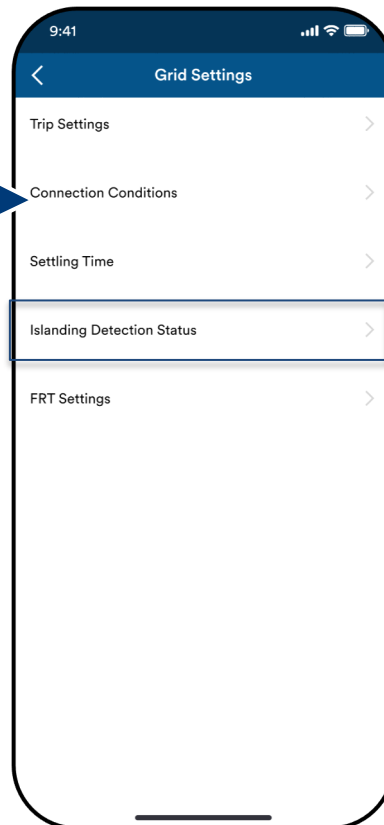

Fig. 165. Select Islanding detection status

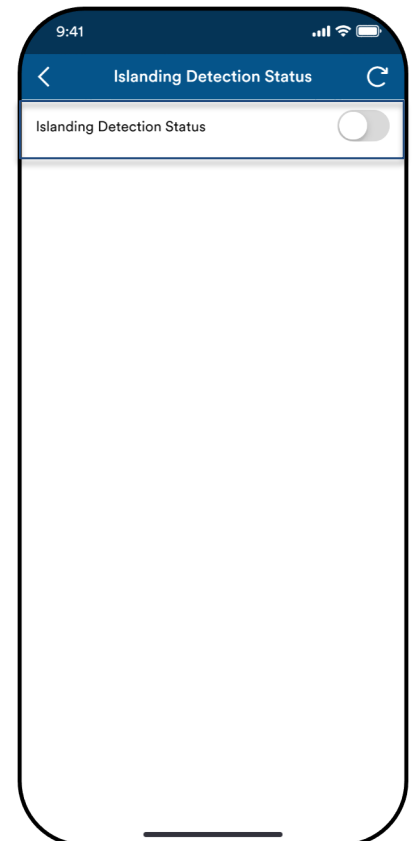

Fig. 166. Activate Islanding detection status

9.9.10 Inverter dynamic network stability setting: LVRT

Note: Displays all set parameters in an overview list.

↻ The <Settings for> menu is opened.

1. Select < Grid Settings > to go to the next screen.

2. Select <FRT Settings >

3. Select <LVRT >

4. Set and check all set parameters.

5. <Confirm> settings.

Note: The additional reactive current should be provided for voltage supporting and it can be chosen according to different standard.

Note: The active current mode during the LVRT also can be chosen according to different standard.

Note: Some special standards maybe need set the additional reactive current to different value for the asymmetrical failure and symmetrical failure.

Note: The voltage type for activation threshold can be chosen as line to line voltage, phase to phase voltage or positive sequence voltage

Note: The activation threshold for voltage sudden change and voltage dips can be set as the percent of the rated voltage. The activation threshold for the additional to the requirements for the zero current mode can be set as the percent of the rated voltage.

Note: The gradient k factor can be configurable in the range of 0 – 10.

» Parameter overview displayed.

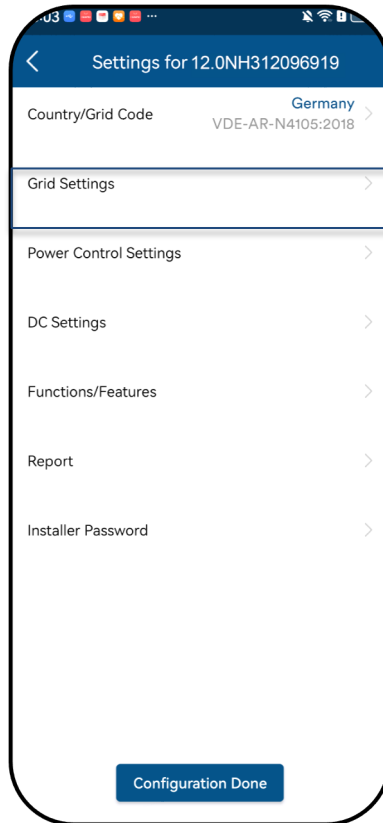

Fig. 167. Select grid settings

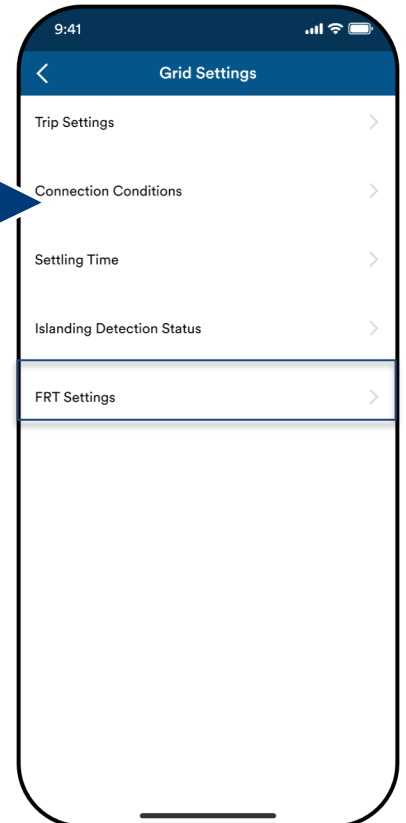

Fig. 168. Select FRT Settings



Fig. 169. Select LVRT

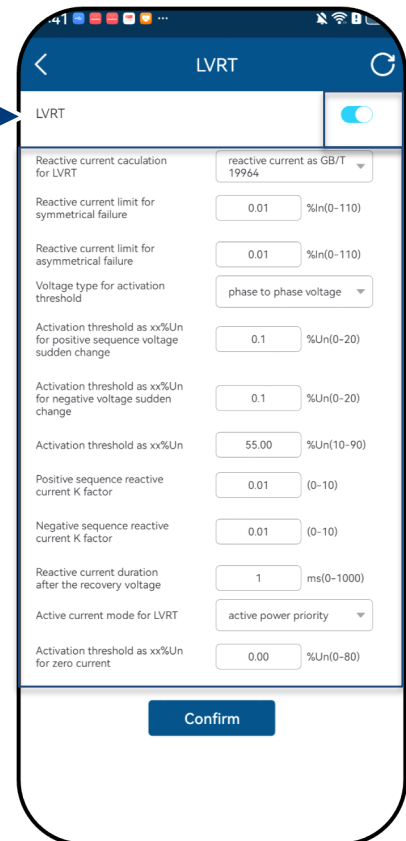

Fig. 170. Set LVRT parameters

9.9.11 Inverter dynamic network stability setting: HVRT

Note: Displays all set parameters in an overview list.

↻ The <Settings for> menu is opened.

1. Select < Grid Settings > to go to the next screen.

2. Select <FRT Settings >

3. Select <HVRT >

4. Set and check all set parameters.

5. <Confirm> settings.

Note: The additional reactive current should be provided for voltage supporting and it can be chosen according to different standard.

Note: The active current mode during the HVRT also can be chosen according to different standard.

Note: Some special standards maybe need set the additional reactive current to different value for the asymmetrical failure and symmetrical failure.

Note: The voltage type for activation threshold can be chosen as line to line voltage, phase to phase voltage or positive sequence voltage.

Note: The activation threshold for voltage sudden change and voltage raise can be set as the percent of the rated voltage. The activation threshold for the additional to the requirements for the zero current mode can be set as the percent of the rated voltage.

Note: The gradient k factor can be configurable in the range of 0 – 10.

» Parameter overview displayed.

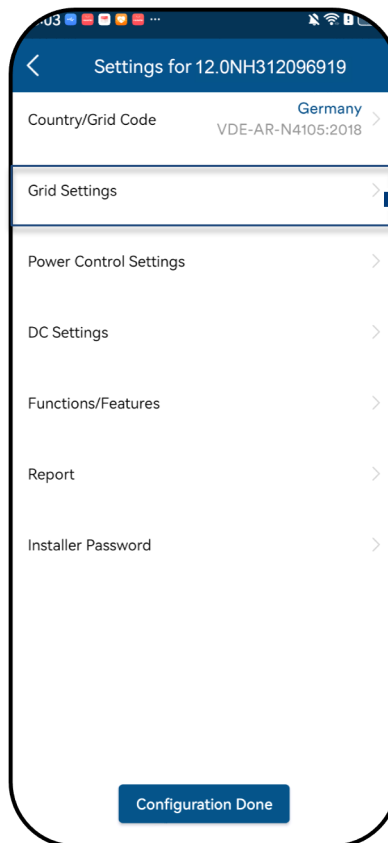

Fig. 171. Select grid settings

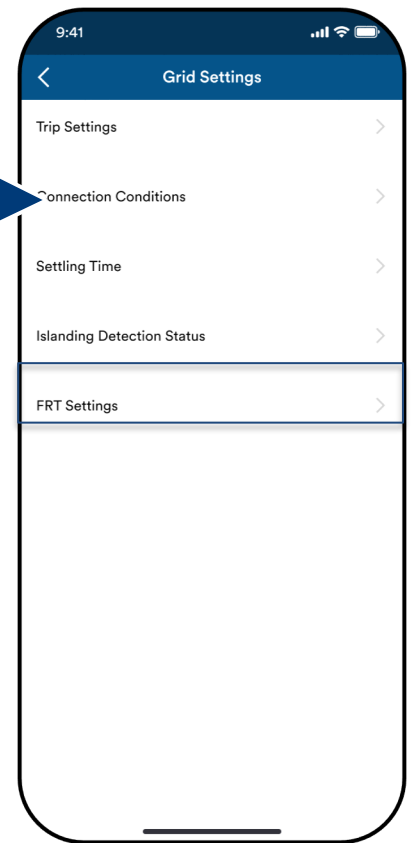

Fig. 172. Select FRT Settings



Fig. 173. Select HVRT

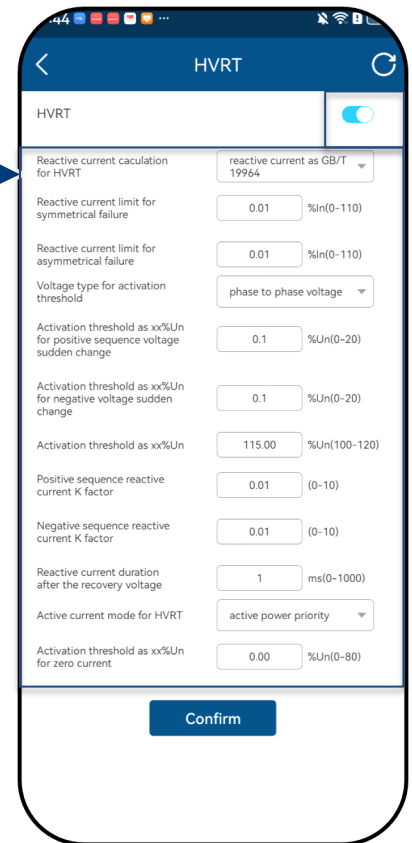

Fig. 174. Set HVRT parameters

9.9.12 P(f) settings

Note: With a programmable frequency threshold with programmable P range, the inverter can activate the active power response to underfrequency.

🔄 The <Settings for> menu is opened.

1. Select the <Power Control Settings>.
 2. Select the <P(f) Settings>.
 3. Select mode > see note below on the 4 modes.
 4. Define frequency range.
 5. Set relative power reduction.
 6. Set internal delay time P(f).
 7. Define min. delay time for power reduction.
 8. Define power gradient after resetting the frequency.
- » P(f) defined.

Legend for Fig. 178+Fig. 179: f_n : Nominal frequency; f_{reset} : Reset frequency; f_{start} : Start frequency; f_{stop} : Stop frequency; ΔP : Active power in % during reduction.

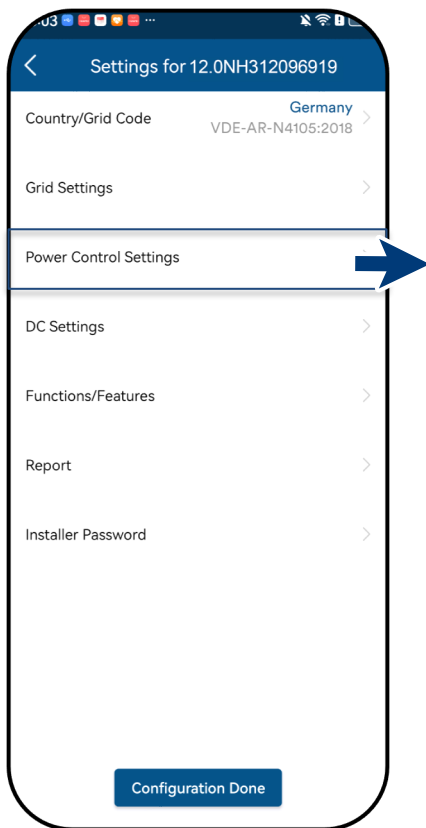

Fig. 175. Select power control settings

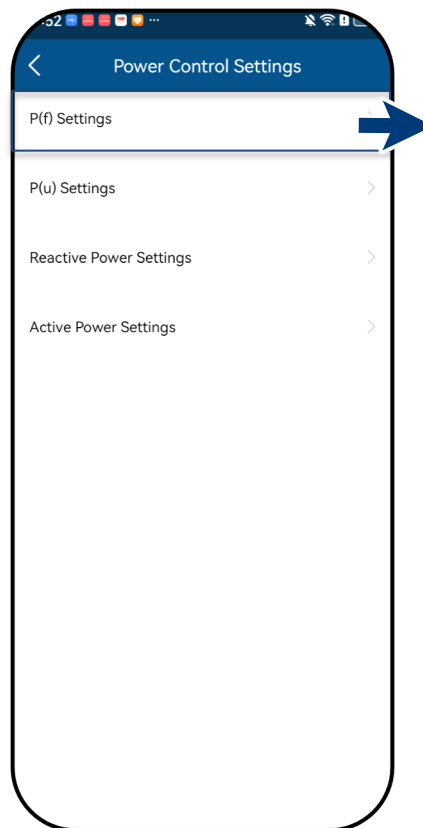

Fig. 176. Select P(f) settings

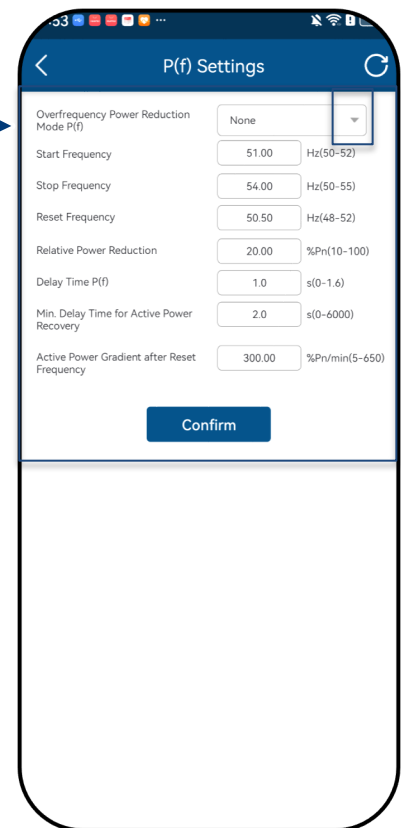

Fig. 177. Set the P(f) parameters

Note: The following 4 modes are available for selection:

1. Fixed gradient and non-hysteresis: ΔP is the active power as a percentage of P_n ; the inverter provides non-hysteresis in the control of active power response to overfrequency
2. Variable gradient and non-hysteresis: ΔP is the active power as a percentage of P_M ; the inverter provides non-hysteresis in the control of active power response to overfrequency.
3. Fix gradient and hysteresis: ΔP is the active power as a percentage of P_n ; the inverter provides hysteresis in the control of active power response to overfrequency

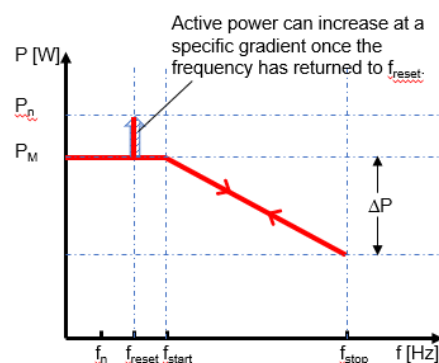

Fig. 178. Non-hysteresis

4. Variable gradient and hysteresis: ΔP is the active power as a percentage of the PM; the inverter provides hysteresis in the control of active power response to overfrequency.

Note: The intentional delay time for $P(f)$ is only used for the activation of the function in accordance with the frequency via f_{start} , whereby the intentional delay time plus own dead time must be smaller than 2s.

Note: The minimum delay time for enabling of the active power is the delay time during which the active power can increase once the frequency has fallen below f_{reset} .

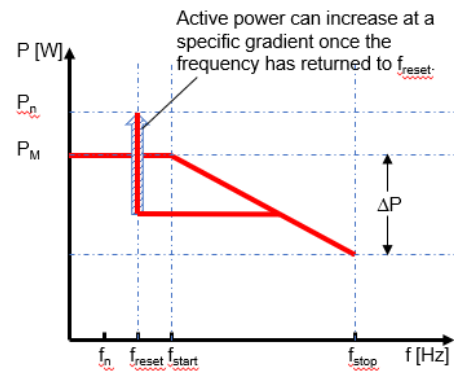

Fig. 179. Hysteresis

9.9.13 P(U) settings

Note: With a programmable voltage threshold with programmable P range, the inverter can activate the active power response to overvoltage.

⊞ The <Settings for> menu is opened.

1. Select the <Power Control Settings>.
 2. Select the <P(u) Settings>.
 3. Select mode > see note below on the 4 modes.
 4. Define voltage range.
 5. Define relative power reduction.
 6. Set internal delay time P(u).
 7. Define min. delay time for power reduction.
 8. Define power gradient after resetting the frequency.
- » P(u) defined.

Legend for Fig. 183+ Fig. 184 Un: Nominal voltage; U_{reset}: Reset voltage; U_{start}: Start voltage; U_{stop}: Stop voltage; ΔP : Active power in % during reduction.

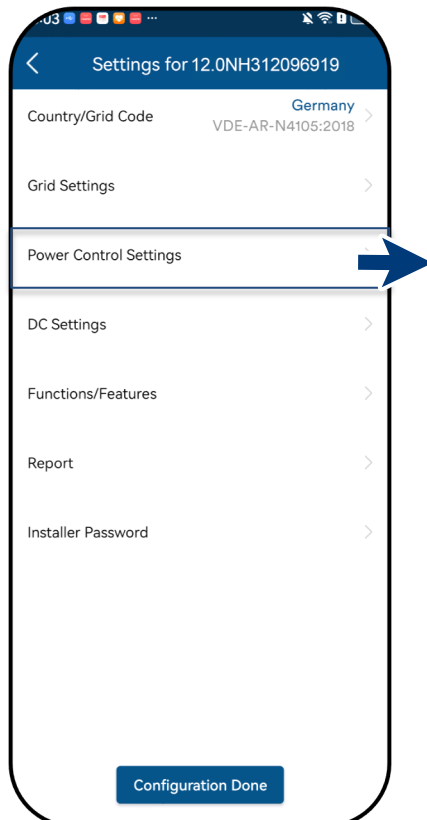

Fig. 180. Select power control settings

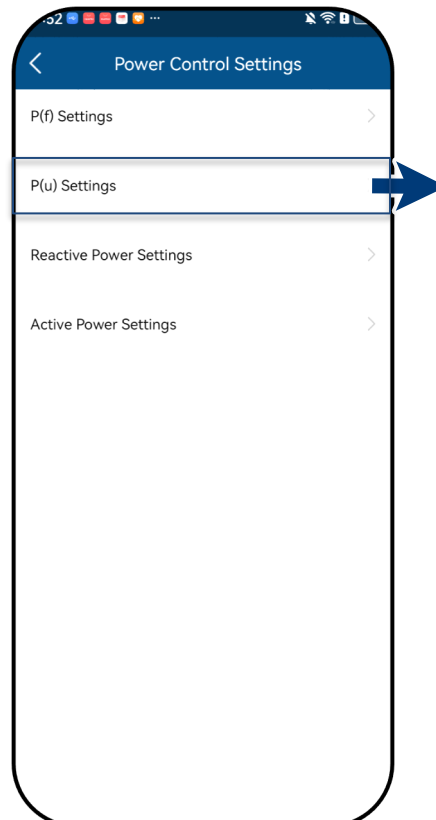

Fig. 181. Select P(u) settings

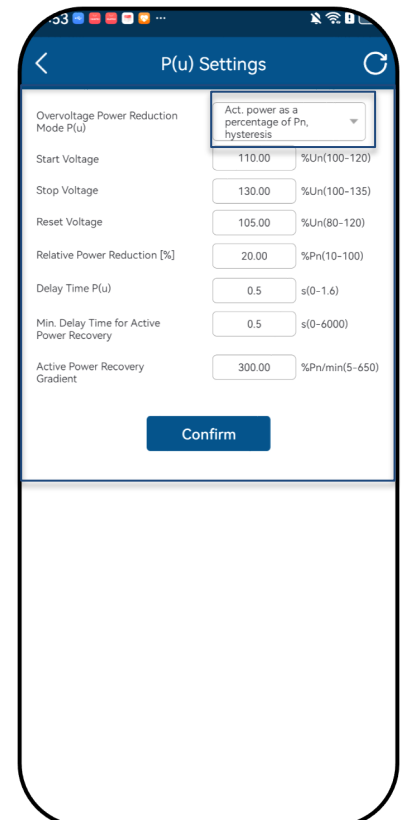

Fig. 182. Set the P(u) parameters

Note: The following 4 modes are available for selection:

1. Fix gradient and non-hysteresis: ΔP is the active power as a percentage of P_n ; the inverter provides non-hysteresis in the control of active power response to overvoltage.

2. Variable gradient and non-hysteresis: ΔP is the active power as a percentage of the P_M ; the inverter provides non-hysteresis in the control of active power response to overvoltage.

3. Fix gradient and hysteresis: ΔP is the active power as a percentage of P_n ; the inverter provides hysteresis in the control of active power response to overvoltage.

4. Variable gradient and hysteresis: ΔP is the active power as a percentage of the P_M ; the inverter provides hysteresis in the control of active power response to overvoltage.

Note: The intentional delay time for $P(u)$ is only used for the activation of the function in accordance with the voltage via U_{start} , whereby the intentional delay time plus own dead time must be smaller than 2s.

Note: The minimum delay time for enabling of the active power is the delay time during which the active power can increase once the voltage has fallen below U_{reset} .

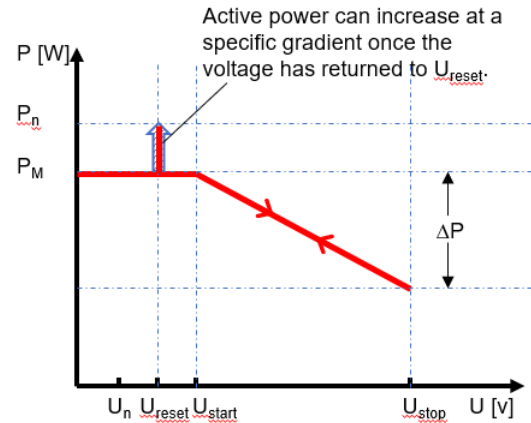

Fig. 183. Non-hysteresis

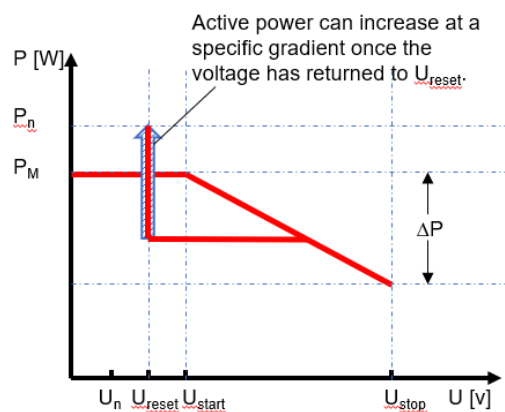

Fig. 184. Hysteresis

9.9.14 Reactive Power Settings

Note: Reactive power can be used in electrical energy supply networks to bolster the level of voltage. As such, feed-in inverters can contribute to statistical voltage stability.

⌚ The <Settings for> menu is opened.

1. Select the <Power Control Settings>.

2. Select the <Reactive Power Settings>.

3. Set subsequent processes <Cos-phi constant>, <Cos-phi(P)>, <Q constant>, <Q(U)>, <Min Cos-Phi for Low Active Power>

Note: A change in the reactive power may be necessary in order to meet the requirements of a first-order filter.

» Reactive power process defined.

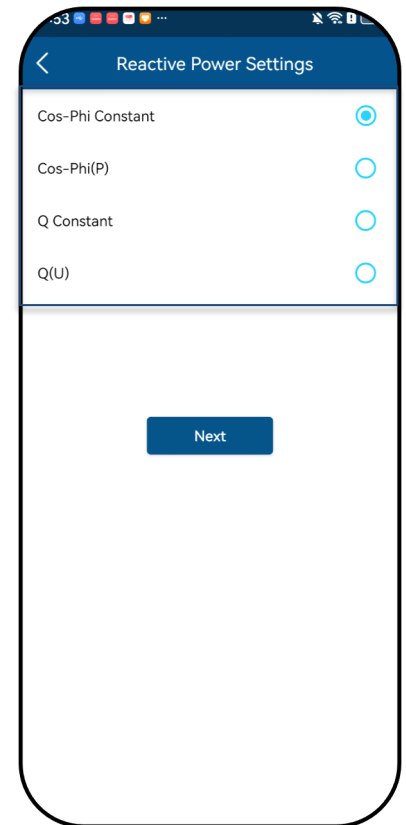
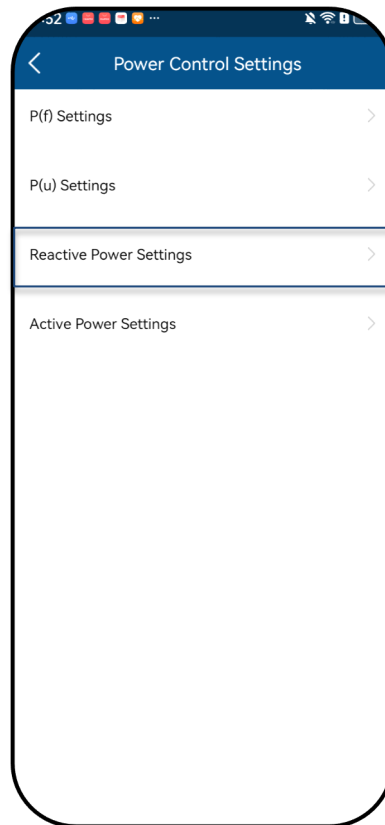
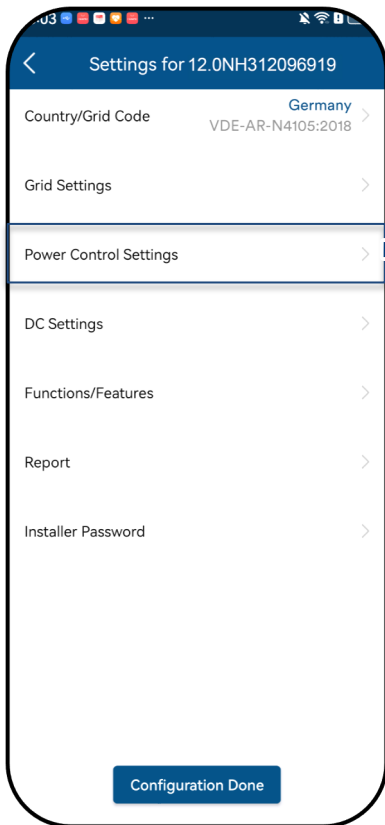

Fig. 185. Select power control settings

Fig. 186. Select reactive power settings

Fig. 187. Select reactive power mode

Basis: There are four types of reactive power control. Only one mode of operation can be active at any given moment.

From the perspective of the grid, the inverter behaves like a load in accordance with the national standard. This means that the inverter operates in quadrant II (under-excited) or III (over-excited) as shown in Fig. 178.

Definition: Over-excited reactive power, also known as capacitive reactive power or leading power factor.

Under-excited reactive power, also known as inductive reactive power or lagging power factor.

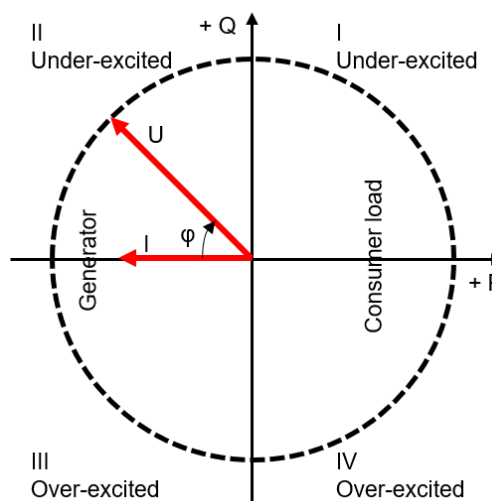

Fig. 188. Load reference arrow system

9.9.14.1 Cos-phi constant settings

Note: In $\cos \phi$ constant mode, the specified power factor is permanently set by the inverter. In doing so, the reactive power level is set in line with $Q=P \cdot \tan \phi$ as a function of the power that continuously generates the specified power factor.

↻ The < Reactive Power Settings > menu is opened.

1. Select < Cos-phi constant >, and click < Next >
 2. Set the <Cos-phi> target value.
 3. Select the excitation type from the drop-down field.
 4. Save settings with <Confirm>.
- » Cos-phi constant defined.

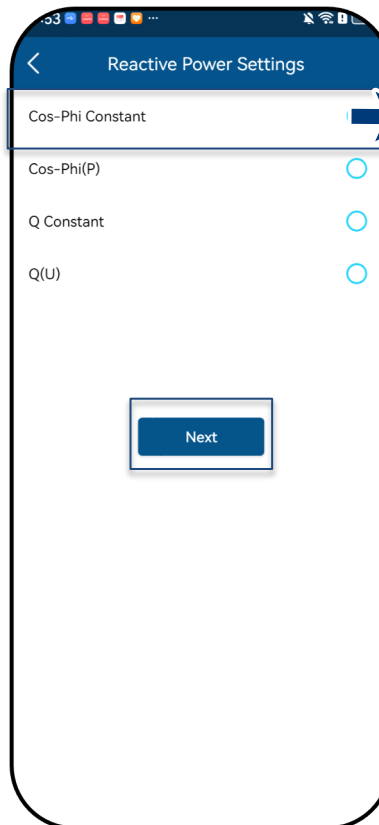

Fig. 189. Select cos-phi constant

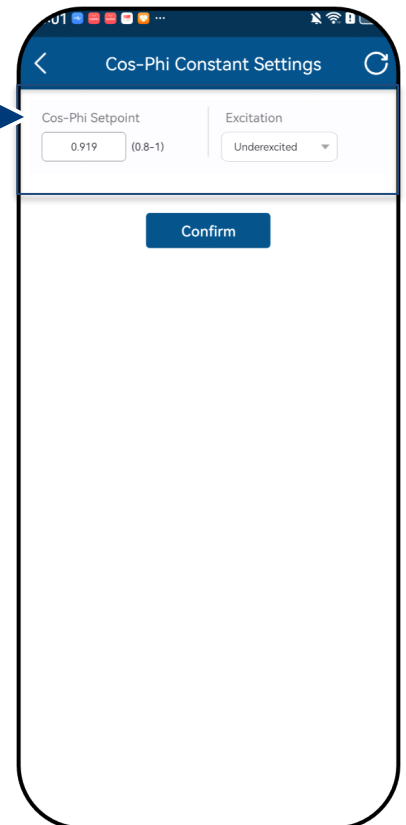

Fig. 190. Define the cos-phi target value

9.9.14.2 Cos-phi (P) settings

Note: Power-based control $\cos \phi(P)$ regulates the $\cos \phi$ value of the power depending on the emitted active power. 4 coordinates can be set in order to map the P curve.

↻ The < Reactive Power Settings > menu is opened.

1. Select <Cos-phi (P) >, and click < Next >
2. Define P/P_n, $\cos \phi$ and excitation for each of the 4 nodes.
3. Set the <Activation voltage>.

Note: Activation threshold as a percentage of U_n corresponds to the "Lock-In" voltage.

4. Set the <Deactivation voltage>.

Note: Deactivation threshold as a percentage of U_n corresponds to the "Lock-Out" voltage.

5. Save settings with <Confirm>.

» $\cos \phi(P)$ defined.

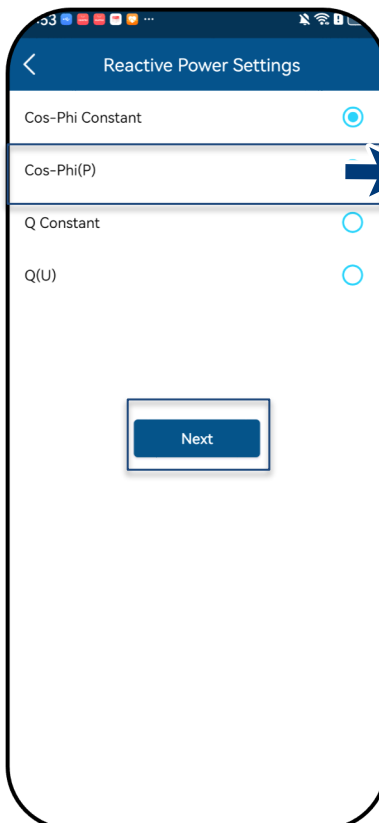

Fig. 191. Select cos-phi (P) settings

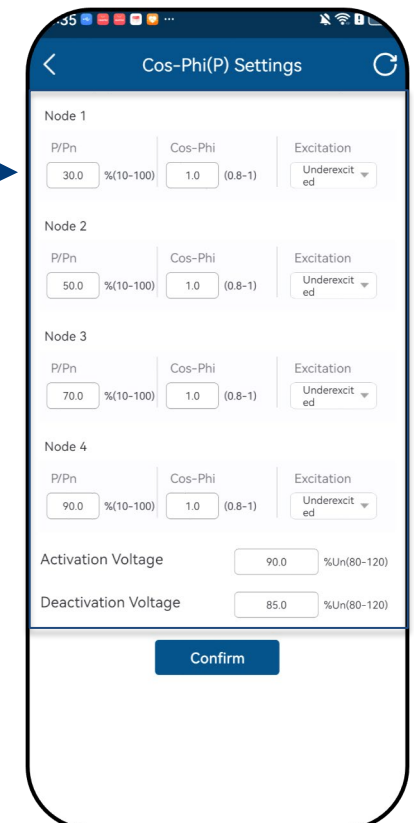

Fig. 192. Set cos-phi (P) parameters

Definition:

The coordinates are the active power as a percentage of P_n and the displacement factor $\cos\phi$.

A grid operator can specify two voltage thresholds as a percentage of P_n to activate or deactivate the function. The voltage thresholds are normally referred to as the "Lock-In" and the "Lock-Out" voltage.

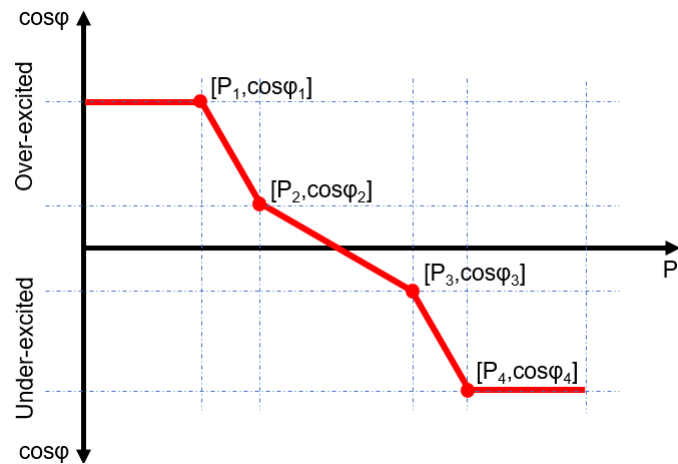

Fig. 193. Cos-phi(P) curve

9.9.14.3 Q constant settings

Note: The target value of the reactive power can be adjusted depending on the set maximum apparent power.

↻ The < Reactive Power Settings > menu is opened.

1. Select < Q Constant >, and click < Next >
 2. Set < Q > in %.
 3. Select the excitation type from the drop-down field.
 4. Save settings with < Confirm >.
- » Q constant > defined.

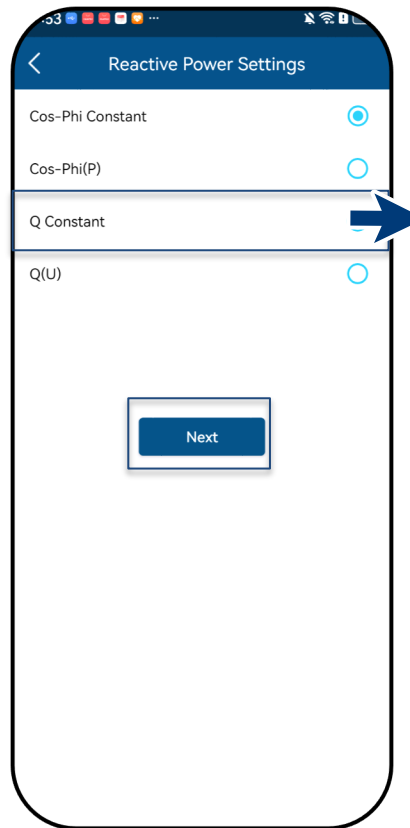

Fig. 194. Select Q constant settings

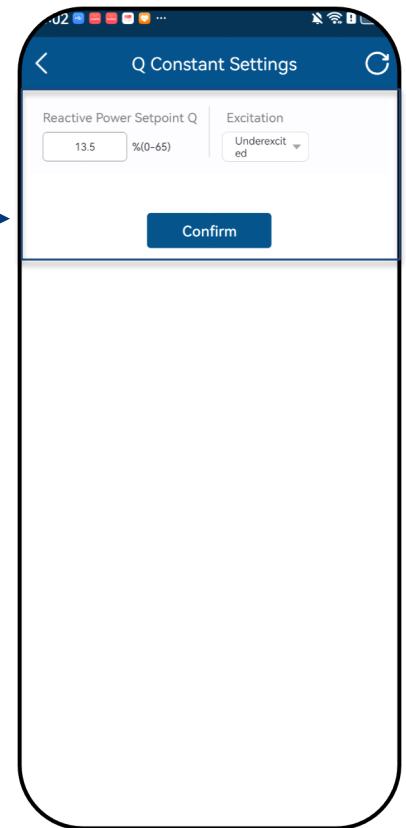

Fig. 195. Enter reactive power target value Q

9.9.14.4 Q(U) settings

Note: Voltage-dependent control Q(U) regulates the reactive power output depending on the voltage. 4 coordinates can be set in order to map the curve.

↻ The < Reactive Power Settings > menu is opened.

1. Select the < Q(U) >, and click < Next >
2. Define U/U_n , Q/S_n and phase for each of the 4 coordinates.
3. Set the <Activation power> in % of P_n .

Note: Activation threshold as a percentage of P_n corresponds to the “Lock-In” voltage.

3. Set the <Deactivation power> in % of P_n .

Note: Deactivation threshold as a percentage of P_n corresponds to the “Lock-Out” voltage.

4. Save settings with <Confirm>.

» Q(U) curve defined.

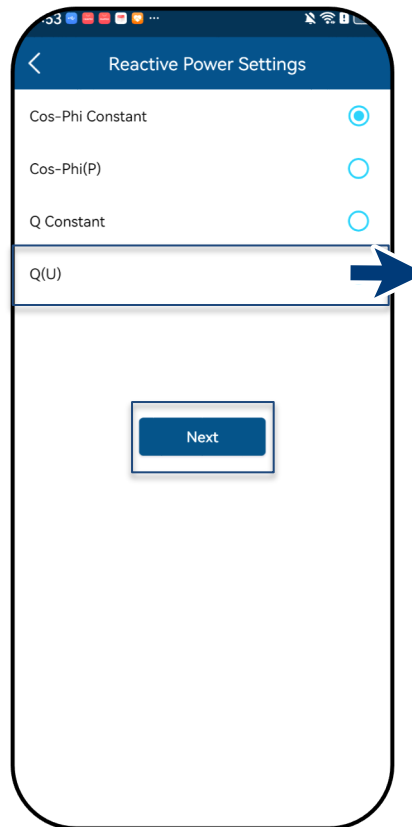

Fig. 196. Select Set Q(U) settings

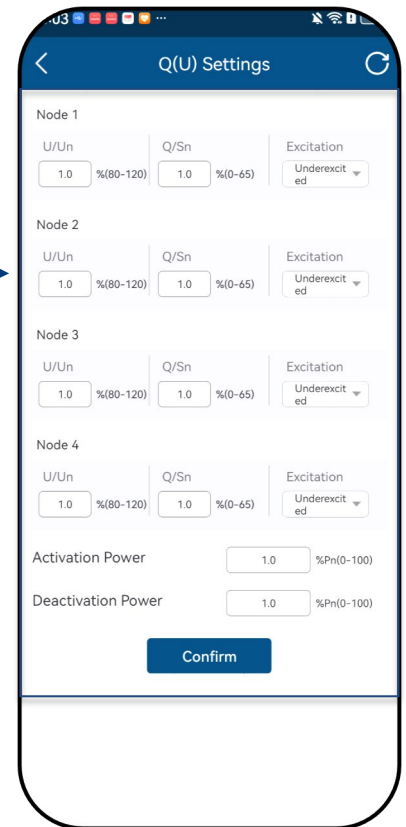

Fig. 197. Set the Q(U) parameters

Definition:

The coordinates are the voltage as a percentage of U_n and the reactive power as a percentage of P_n .

A grid operator can specify two active power thresholds as a percentage of U_n to activate or deactivate the function. The active power thresholds are normally referred to as the “Lock-In” and the “Lock-Out” active power.

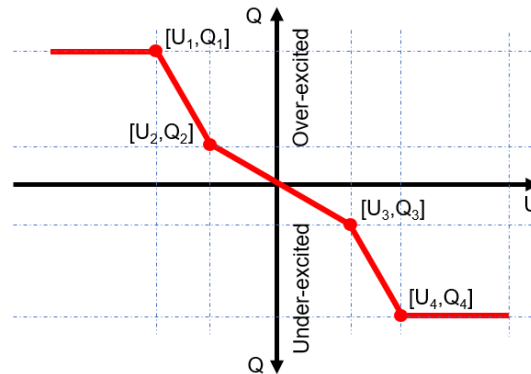

Fig. 198. Q(U) curve and non-hysteresis

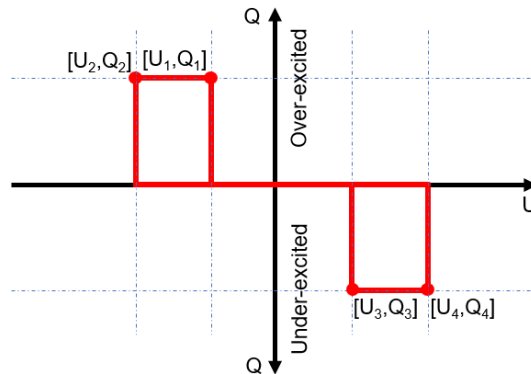

Fig. 199. Q(U) curve and hysteresis

9.9.14.5 Min Cos-Phi for Low Active Power

Note: If the Austria safety standard is currently selected by the user, "Min Cos-Phi for Low Active Power" is displayed and can be set.

↻ The < Reactive Power Settings > menu is opened.

1. Select the <Min Cos-phi for Low Active Power>.

2. Set the <Min Cos-Phi for Low Active Power>.

3. Save settings with <Confirm>.

» Min Cos-Phi is set.

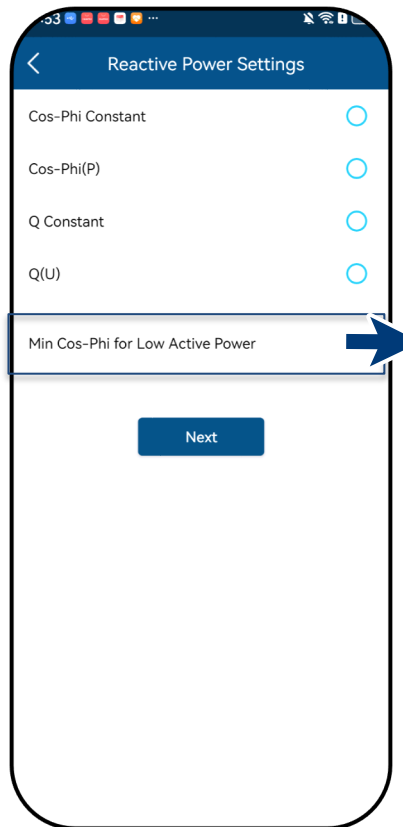

Fig. 200. Select Min Cos-Phi for Low Active Power

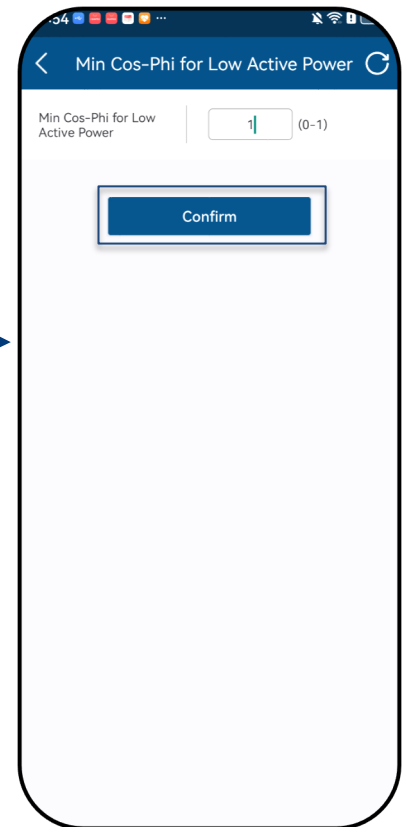

Fig. 201. Parameter for Austria Active Power

Definition:

The Minimum cos-phi is a limit value during the reactive power regulation. When the active power is very low, maybe the inverter can't output the required reactive power, then the inverter can output the reactive power as the minimum cos-phi.

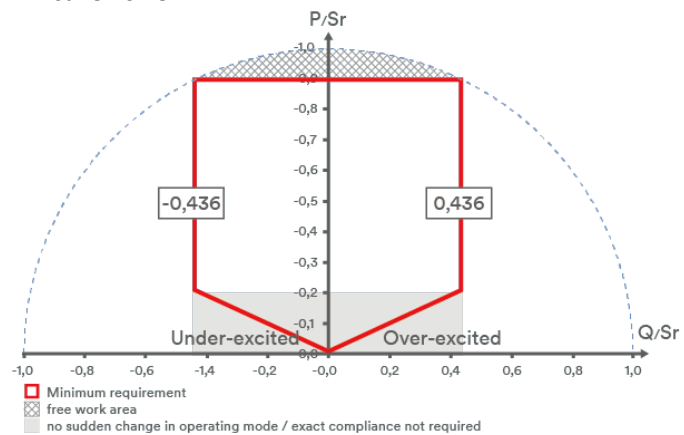

Fig. 202. Minmum cos-phi limited

9.9.15 Active Power Settings (power limitation)

Note: During changing in AC operation and control or changing in energy source operation, the active power generated by the inverter shall not exceed a specified gradient expressed as a percentage of the active nominal power of the inverter per minute. You can set 'Increasing Gradient' and 'Decreasing Gradient' according to the requirement.

Note: The output power of the device can be set permanently to a lower value than the maximum output power by the power limitation. This may be necessary in order to limit the maximum power rating of the system at the grid connection point, upon the grid operator's request.

🔄 The <Settings for> menu is opened.

1. Select the <Power Control Settings>.
2. Select the <Active Power Settings>.
3. Set <Max. active power> dependent on P_n in %.
4. Set the <Increasing Gradient> and <Decreasing Gradient> of the active power
5. Save settings with <Confirm>.

Note: When switching to AC operation and control and when switching to energy generation mode, the active power generated by the device must not exceed a certain gradient expressed as a percentage of the nominal active power of the inverter per minute.

» Power limitation defined.

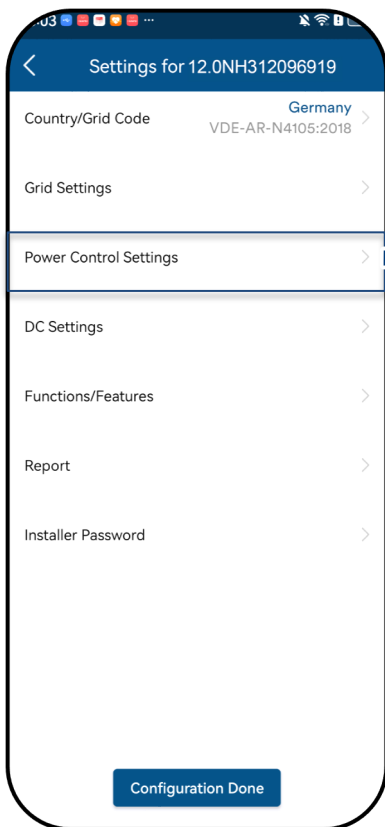

Fig. 203. Select power control settings

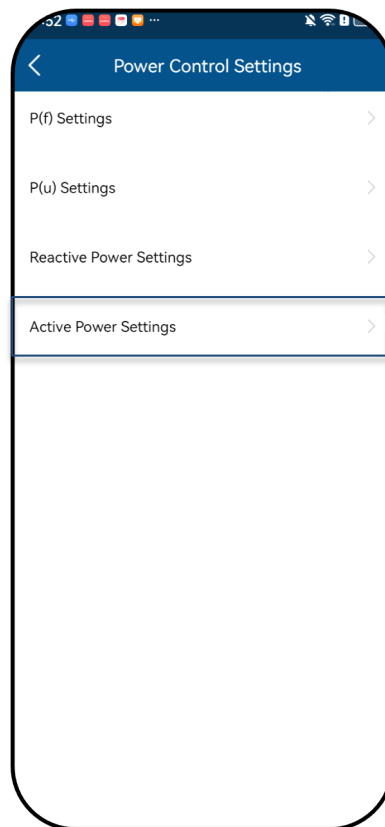

Fig. 204. Select active power settings

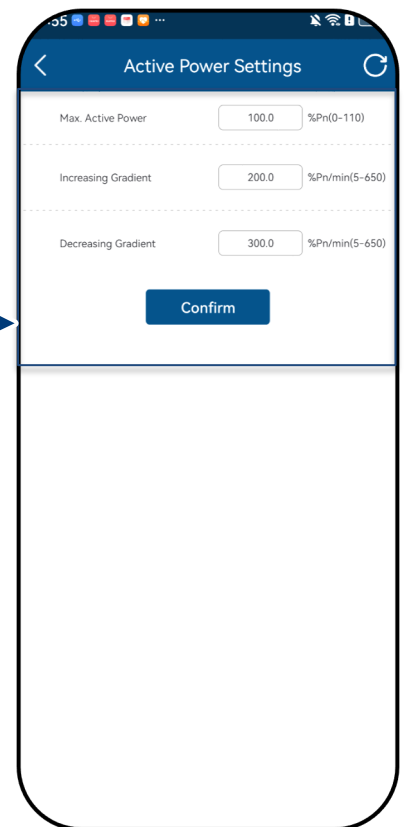

Fig. 205. Define max. AP & gradients

9.9.16 Min. Insulation Resistance Settings

🔄 The <Settings for> menu is opened.

1. Select < DC Settings >

2. Select < Min Insulation Resistance >

3. Specify the <Min. Insulation Resistance>

4. Save settings with <Confirm>.

» Min. Insulation resistance defined.

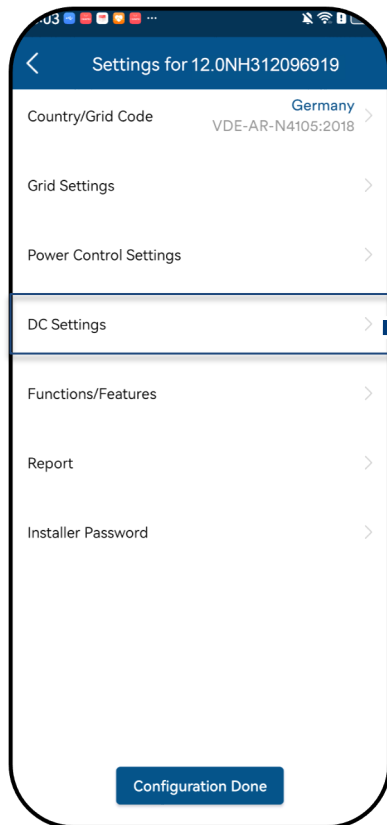

Fig. 206. Select DC settings

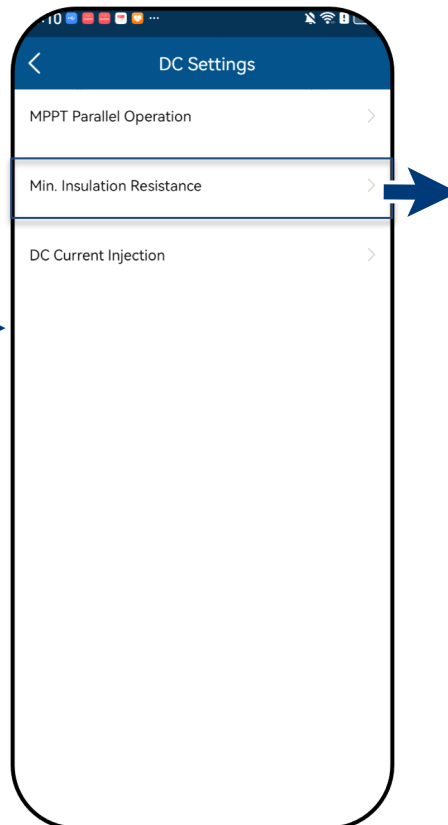

Fig. 207. Select Min insulation resistance

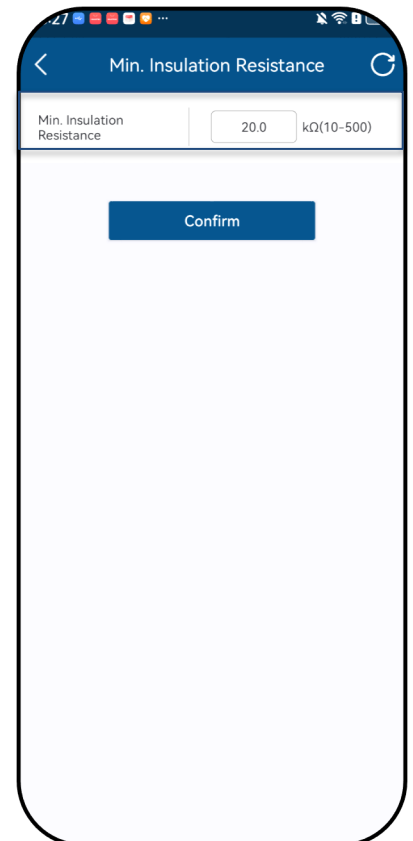

Fig. 208. Set insulation resistance parameters

9.9.17 DC Current Injection Settings

🔄 The <Settings for> menu is opened.

1. Select < DC Settings >

2. Select < DC Current Injection >

3. Set the <Trip DC Current Injection Time>.

4. Specify the <Trip DC Current Injection>.

5. Save settings with <Confirm>.

» DC Current injection defined.

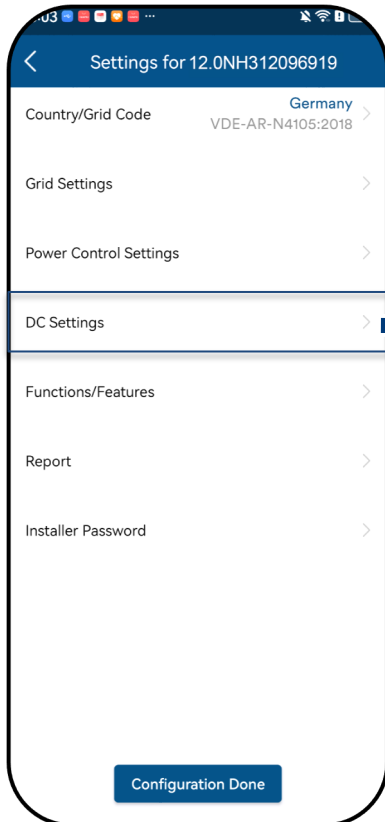

Fig. 209. Select DC settings

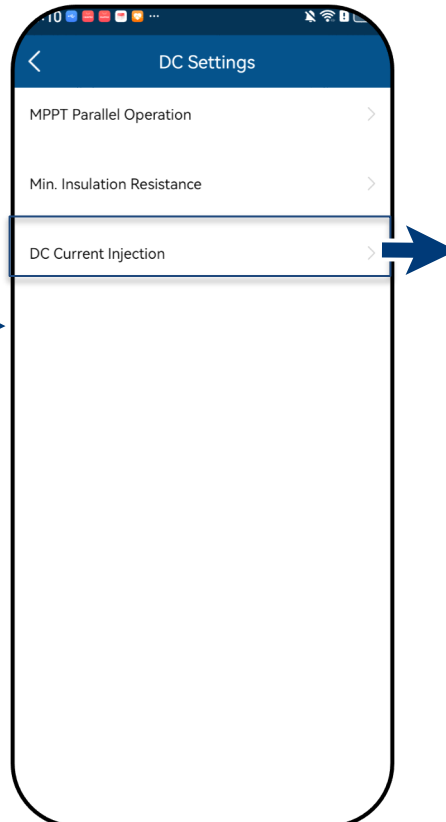

Fig. 210. Select DC current injection

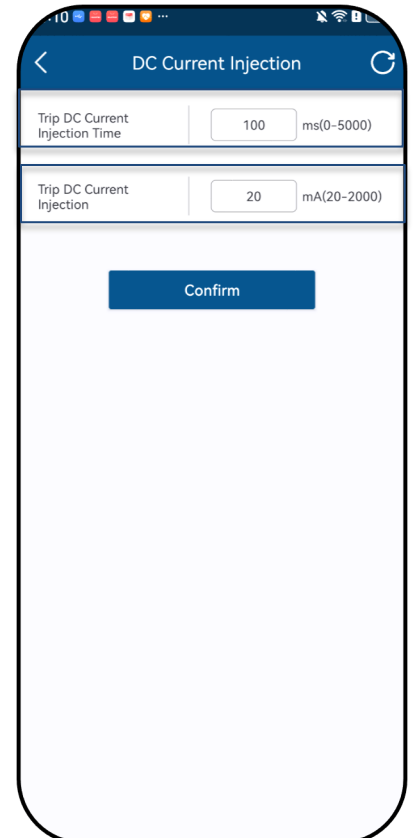

Fig. 211. Set DC parameters

9.9.18 NS-Protection Settings

Note: Depending on the total of the maximum apparent power of all power generation systems and storage systems at a network connection point ΣS_{Amax} , the central network and system protection (NS protection) at the central meter panel may be required. The NS-Protection function should be activated if the central NS Protection device is connected.

↻ The <Settings for> menu is opened.

1. Select < Functions/Features > to go to the next screen.

2. Select < NS-Protection >

3. Activate < NS-Protection >.

4. Enter the password in the <Password> field and confirm with <Confirm>.

Note: For security reasons, the installer password is required to enable NS-Protection.

» NS-Protection set.

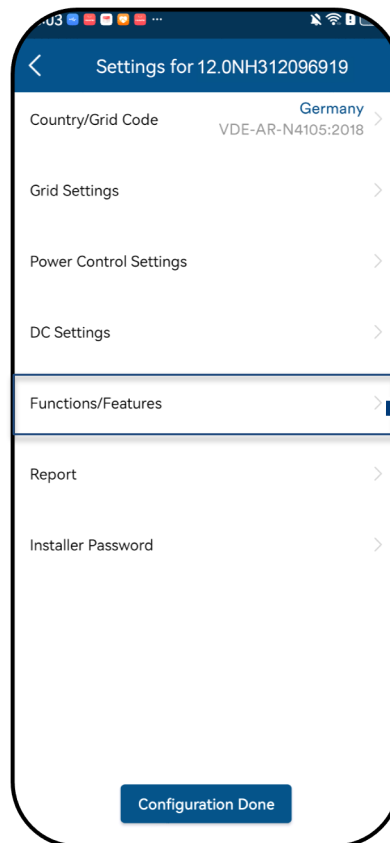

Fig. 212. Select functions / features

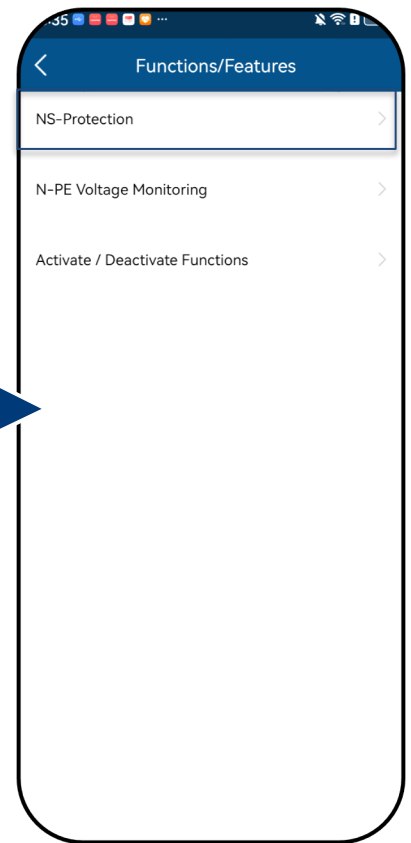

Fig. 213. Select NS-protection s



Fig. 214. Activate NS-protection

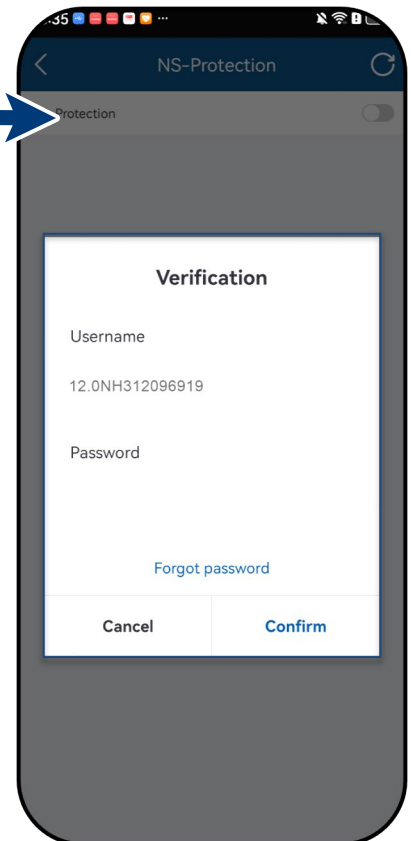

Fig. 215. Authorisation required

9.9.19 N-PE Voltage Monitoring Settings

Note: The N-PE voltage is used to detect whether the PE line is reliably connected. If there is not a second ground connection to earth the inverter, the N-PE voltage monitoring shall be activated.

🔄 The <Settings for> menu is opened.

1. Select < Functions/Features > to go to the next screen.

2. Select < N-PE Voltage Monitoring >

3. Activate < N-PE Voltage Monitoring >.

» Ground fault protective function set.

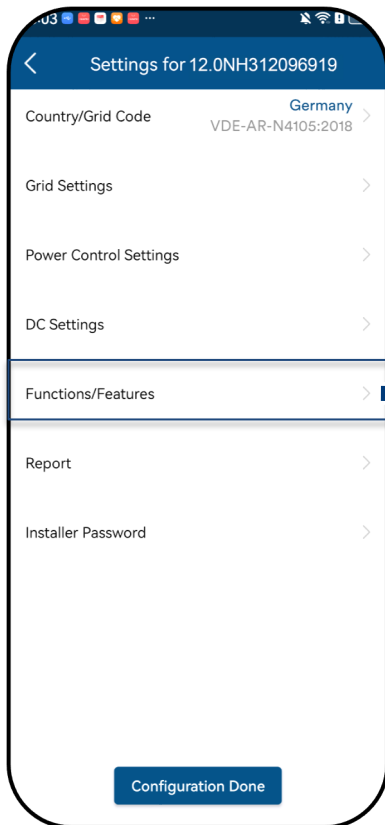

Fig. 216. Select functions / features

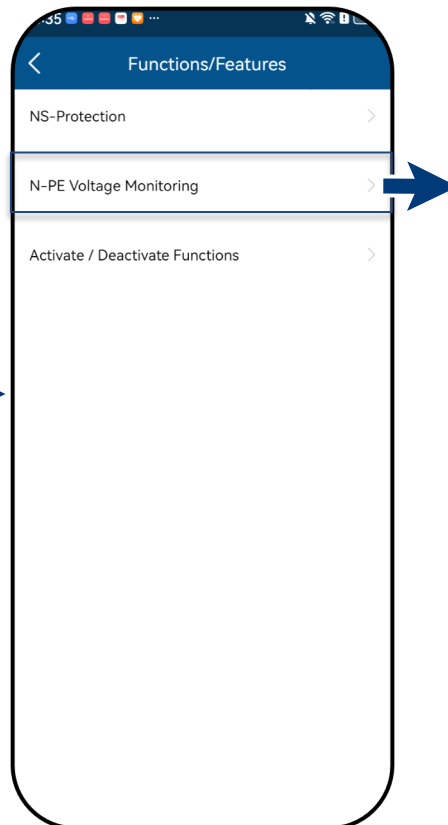

Fig. 217. Select N-PE Voltage Monitoring

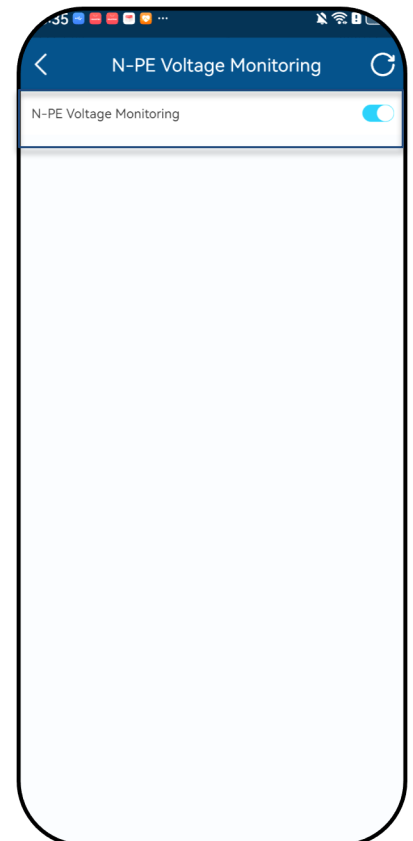

Fig. 218. Activate N-PE Voltage Monitoring

9.9.20 Activate / Deactivate Functions



NOTE

You will find a description of the individual functions starting in Chapter 9.9 from page 70. Further parameters are also being added continuously in the successive firmware versions. For this reason, see the PDF version of these application instructions for important additions.

Note: All required inverter functions can be activated by enabling them as shown below.

↻ The <Settings for> menu is opened.

1. Select < Functions/Features > to go to the next screen.

2. Select < Activate / Deactivate Functions >

3. Here you can see the activate and deactivate features. After the setting has been made in the respective parameter, the function can be enabled.

- 70 % rule (for details, see Chapter 9.12 on page 98)
- Active power ramp up (see Chapter 9.9.15 on page 89)
- P(U) (see Chapter 9.9.13 on page 82)
- P(f) (see Chapter 9.9.12 on page 81)
- Reactive power control (see Chapter 9.9.8 on page 77)
- Trip Overvoltage (10min Average)– protective function
- Islanding Detection Status – protective function
- Active power increase at underfrequency P(f) configuration

4. Confirm selection with < Confirm>. The device then performs a restart with the desired range of functions.

» The desired functions are permanently set.

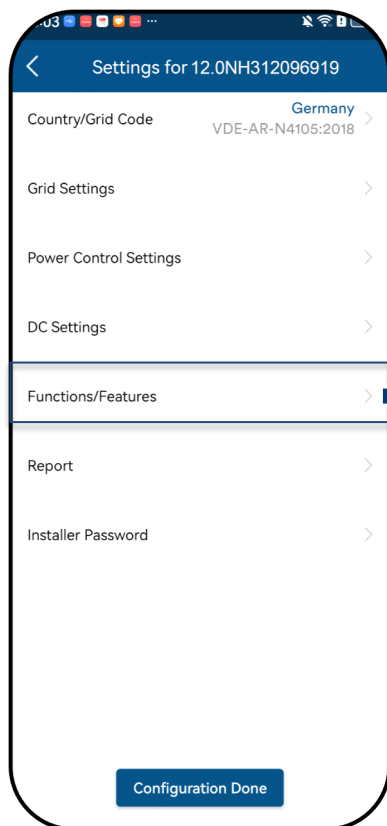

Fig. 219. Select functions / features

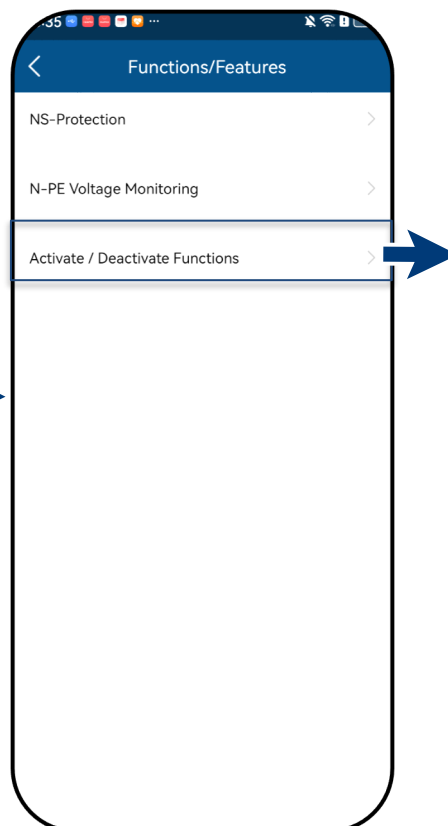

Fig. 220. Select activate / deactivate Functions

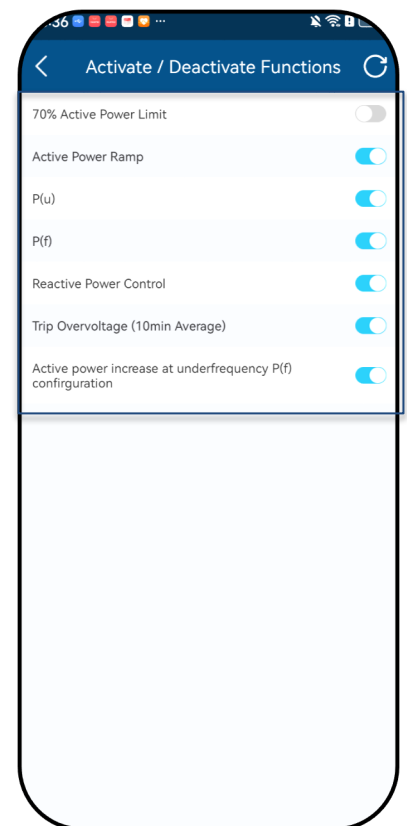

Fig. 221. Toggle required functions

9.9.21 Inverter parameter report

Note: Displays all set parameters in an overview list.

↻ The <Settings for> menu is opened.

1. Select <Report>.

2. Select <Inverter Parameter Report>. The next page will display the parameter.

3. Check all set parameters.

4. Export the set parameters using the <Export PDF> button. This serves as proof of all settings made with regard to the EVU.

» Parameter overview displayed.

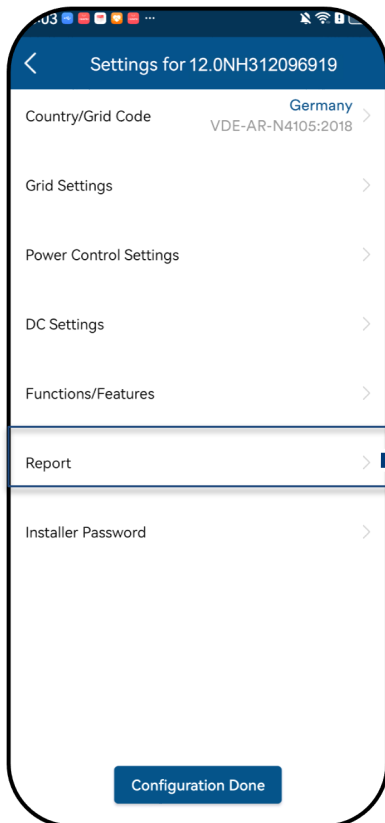

Fig. 222. Select report



Fig. 223. Select inverter parameter report

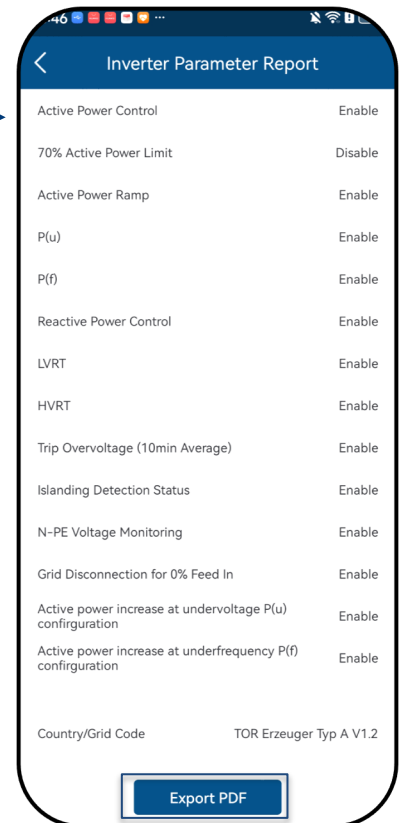

Fig. 224. View all parameters

9.10 Performing a firmware update

Note: This function is a simplify upgrade of the communication device and inverter, need to be available in the router has been configured network, please keep the network smooth during the upgrade process, please do not lock the screen!

1. Download the latest firmware KACO_NH3_Vxx.zip from mykaco.com under Downloads into an empty folder on your mobile device with this KACO APP.

2. Connect to the communication device and select the “Firmware update” page.

3. Click the “Communication device” and click the icon to find the firmware zip file(xxx.zip). After selection of zip file, the firmware should be updated step by step: Communication device, safety, master, HMI

Note: The whole process takes about 25 minutes.

Note: Please keep the DC power> 300W during the upgrade process.

4. Only when all installation steps are confirmed with a checkmark and each process has been successfully confirmed, the menu can be exited.

» The device is updated with the new firmware. Check the installed versions based on the Firmware Release Note

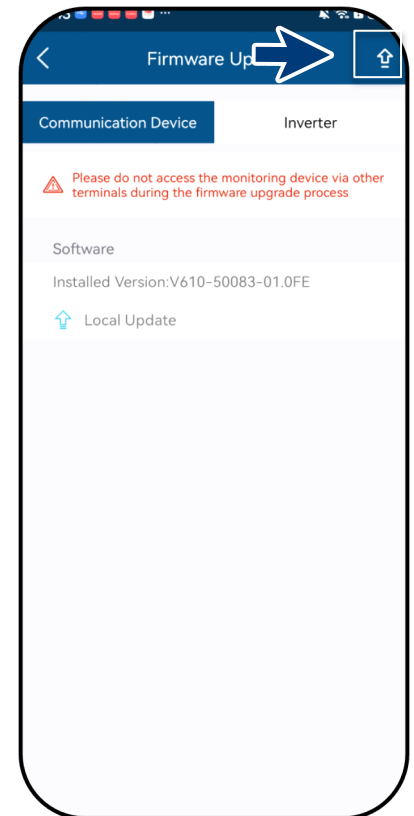
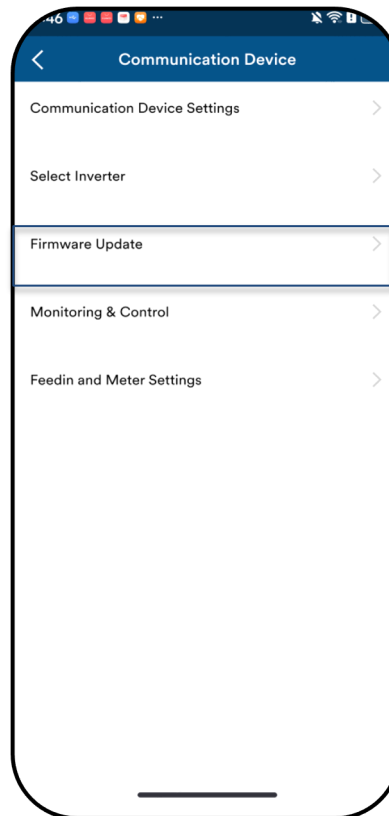

Fig. 225. Select firmware update

Fig. 226. Inverter firmware



NOTE

With the Communication device plugged in, no communication via RS485 is possible during the firmware update.

9.11 Monitoring with “blueplanet smartcloud”

Note: For monitoring all measurement data for PV and battery systems, you can conveniently use KACO's integrated smartcloud. The KACO server is located in Germany to securely store all sensitive customer data long-term.

☰ The <KACO Device Manager> menu has been opened and <KACO Cloud> has been selected.

1 Select <Log In / Sign Up> if you like to register in the KACO Cloud otherwise see demo to view our new datalogging.

Note: In the free version, the sampling rate for all measured data communicated to the cloud is 15 minutes.

Note: If you see potential for improvements, you can use the feedback button to describe your concern.

» Monitoring can be conveniently carried out on a larger display (tablet, monitor).

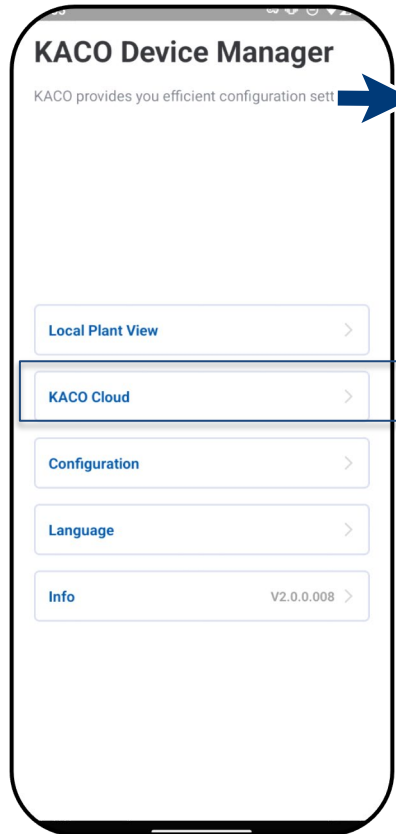

Fig. 227. Select < KACO smartcloud >

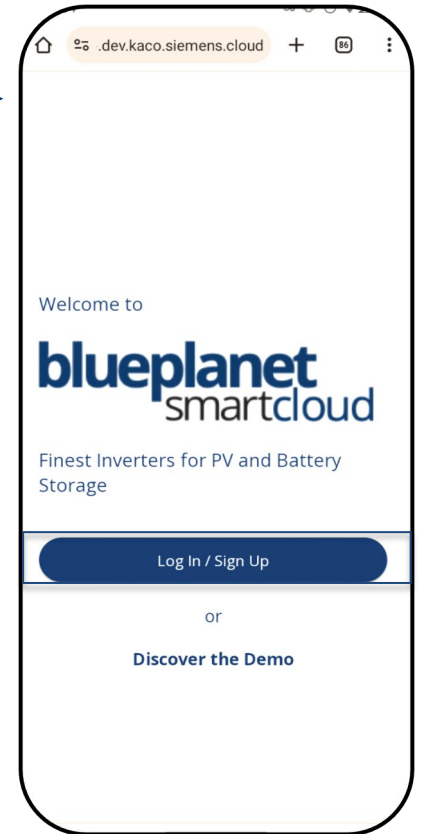

Fig. 228. Sign up for free or view the DEMO version

☰ Log In /sign up> menu has been opened and <KACO smartcloud> has been selected.

1 Enter your login details

Note: New registrations can be made via our customer service

Note: The intuitive interface graphically displays all relevant measurement data, including the degree of self-sufficiency.

Note: In the free version, the sampling rate for all measurement data transmitted to the cloud is 15 minutes.

Note: If you see potential for improvement, you can use the feedback button to describe your concerns.

» Monitoring can be conveniently carried out on a larger display (tablet, monitor).

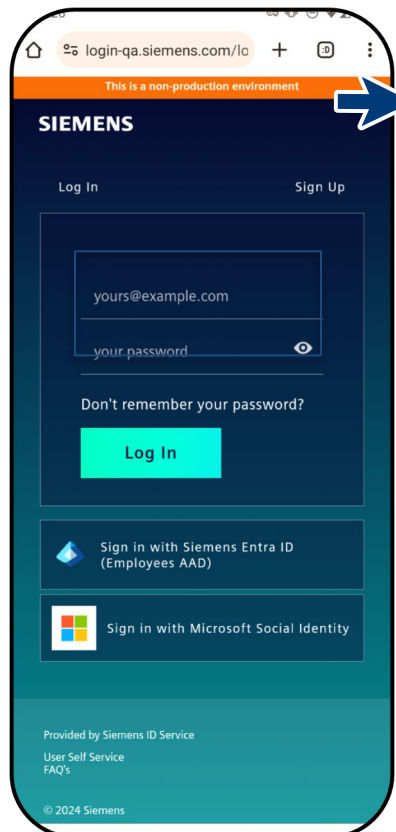

Fig. 229. Administration

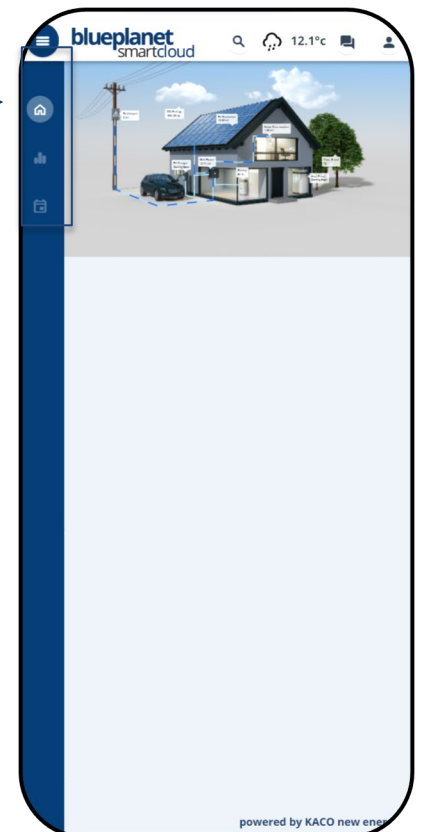

Fig. 230. Plant information

9.12 Information on dynamic feed-in

9.12.1 Control behaviour

With a system output of 7 kWp and above, a digital feed-in meter or a remote control option is still mandatory at present. Active power limitation is the simplest option here. This can be achieved for all NH3 devices via the Smart-Meter or a data logger.

With EEG 2023, the expansion of photovoltaics is to become a topic of overriding public interest. Therefore, new PV systems that are connected to the grid on or after 1 January 2023 and have a capacity of up to 25 kW will be subject to the maximum generation. This involves abolishing the 70% limit on the nominal power that may be fed into the public grid. Consequently, a solar generation meter (Smart-Meter) is no longer necessary.

9.12.2 Increasing the active power limitation

For the feed-in limit to be raised above 70%, a smart meter or data logger must be connected. The total consumption is communicated to the inverter/data logger by the additional Smart-Meter (3-phase) so that it can establish a new maximum feed-in power.

If the feed-in power of a PV system is compared with the consumption of a detached home, a graph such as the following example is produced.

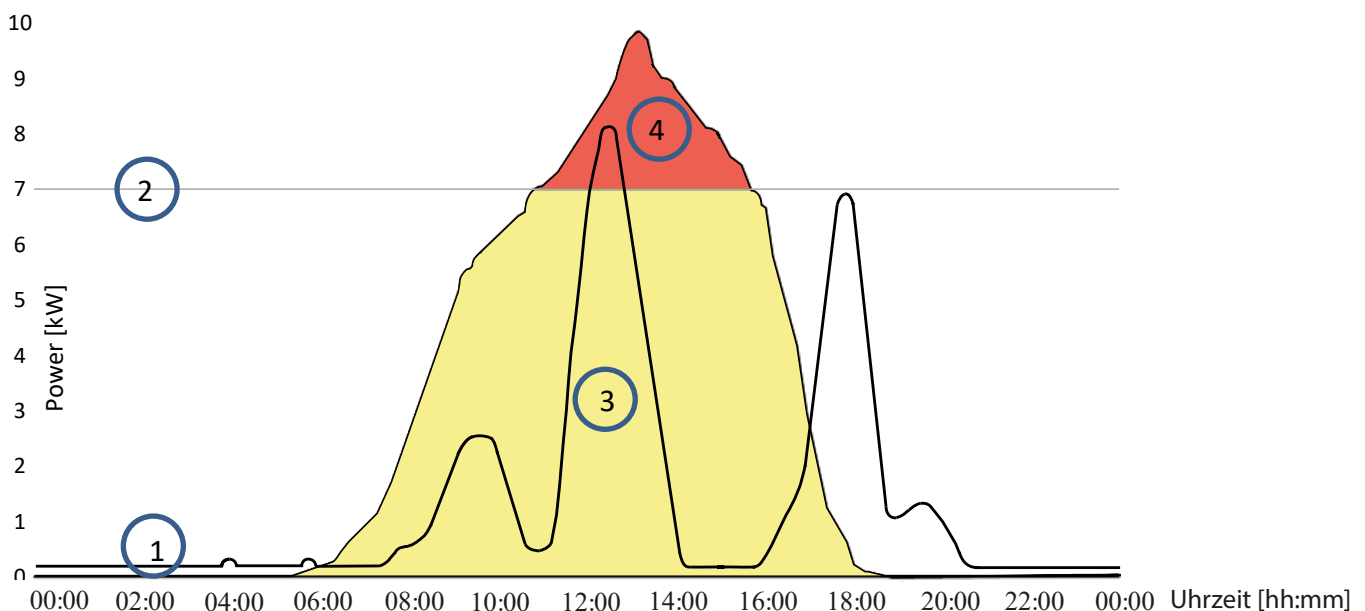

Fig. 231. Diagram comparing the energy requirement of a detached home and PV output

Legend			
1	Energy requirement of a detached home	3	70% feed-in power (yellow area)
2	70% fixed feed-in limit (grey line) – regulation command to inverter	4	Lost feed-in power (red area)

It is evident that there is a constant base load, especially at night (continuous/standby operation of consumers).

Based on this graph, we can now see that the actual self consumption values communicated should result in considerably less power being lost from the PV system.

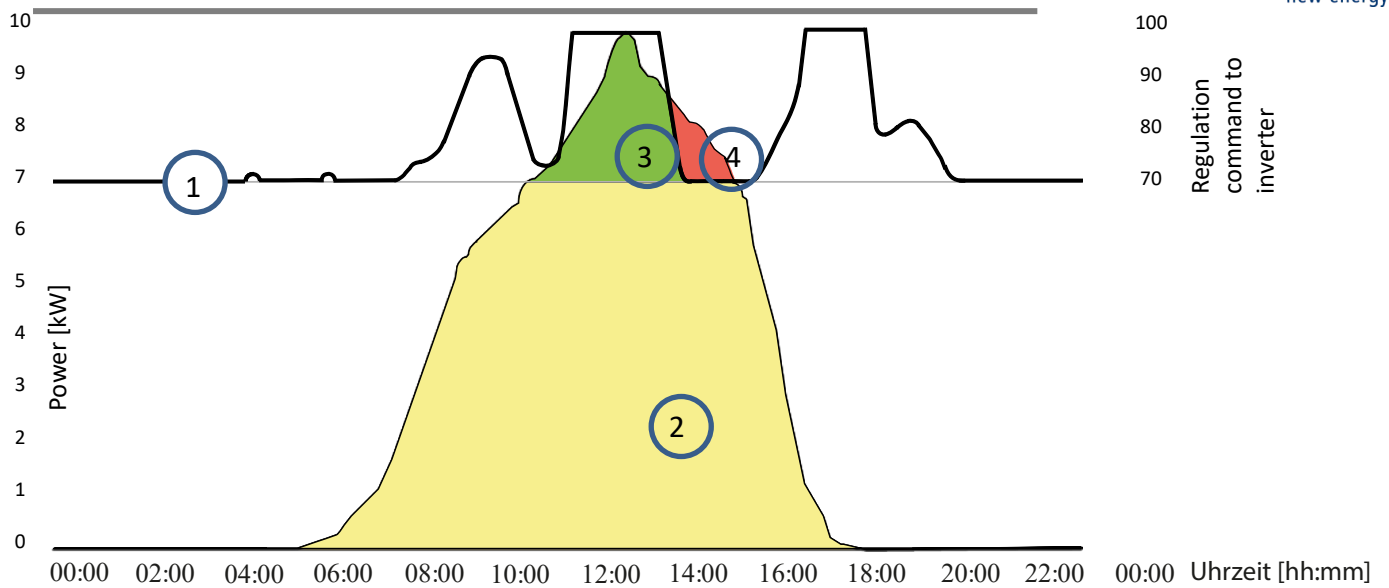

Fig. 232. Diagram of increase in self consumption

Legend			
1	Regulation command to device 70% + self consumption	3	PV power gained through self consumption
2	Energy requirement of a detached home (green area)	4	PV power lost despite self consumption

Using the feed-in meter/data logger for calculations allows more efficient use to be made of the PV system, thus providing more energy for self-consumption.

Graph Fig. 238 also shows that a red area (lost energy) is nevertheless produced because the amount of power consumed by the owner has fallen to 0 but the PV system could provide more electricity. When the self consumption falls to 0 kW, the 70% regulation function takes effect again.

The 0% feed-in regulation, on the other hand, must ensure that there is no feed into the public grid. Depending on the self consumption, the PV system output may be connected up in such a way that the user can make use of the energy generated themselves and nothing has to be purchased from the public grid.

The feed-in meter must therefore be connected to the data logger so that the logger can generate the regulation commands. If an energy meter is not connected to the data logger, the logger continuously sends a regulation command to the inverters with a 0% feed-in maximum. This means that feed-in may not take place.

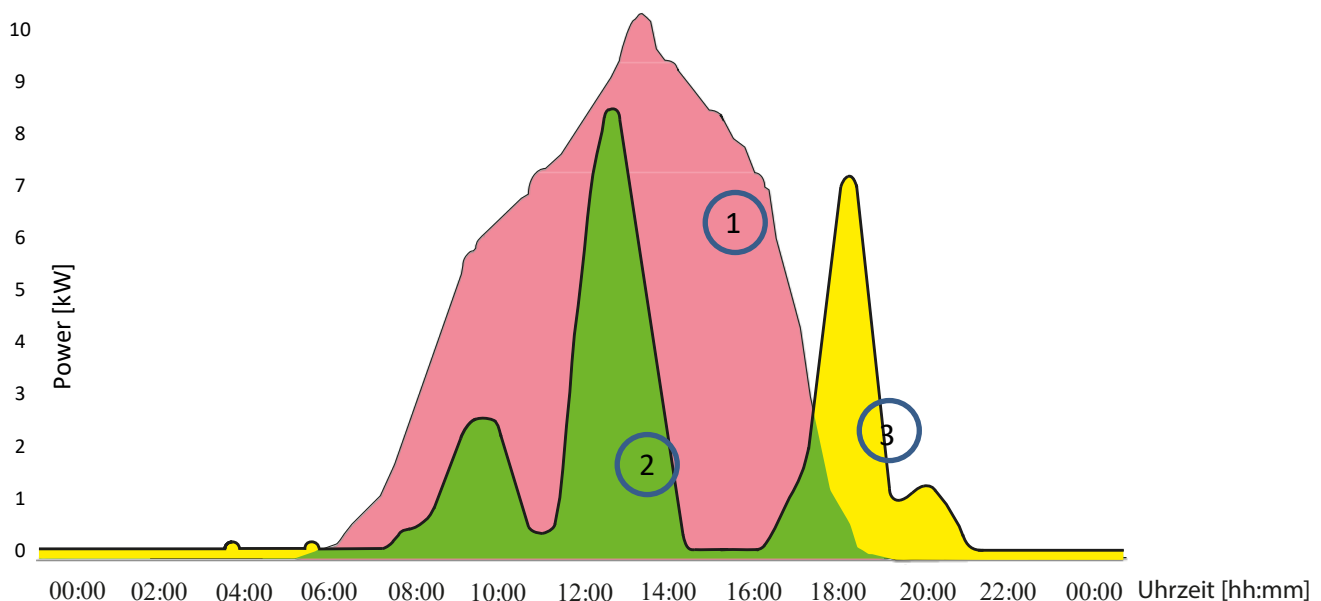

Fig. 233. Diagram of 0% regulation

Legend			
1	PV power available (red area)	3	Bought-in power (yellow area)
2	Energy requirement of a detached home (green area)		

By connecting up additional consumers, heating, water or energy storage systems, the self consumption and therefore the consumption of the PV current can be increased considerably.

This function can however only be used by data logger because this has an S0 output and could therefore connect up additional consumers via a relay circuit.

10 Maintenance and troubleshooting

10.1 Visual inspection

Inspect the device and cables for visible external damage and note the operating status display, where applicable. In case of damage, notify your installer. Repairs may only be carried out by an electrician.

DANGER



Risk of fatal injury due to contact voltages!

Removing the plug connections before disconnecting the device from the PV generator may lead to injuries and damage the device.

- › During installation: Electrically disconnect the DC positive and DC negative from the protective earth (PE).
- › Disconnect the device from the PV generator using the integrated DC isolator switch.
- › Remove the plug connector.

DANGER



Dangerous voltage due to two operating voltages

Coming into contact with the lines and/or terminals/busbars in the device can cause serious injury or death. The discharge time of the capacitors is up to 5 minutes.

- › Only appropriately qualified electricians authorised by the mains supply network operator are permitted to open and maintain the device.
- › Before opening the device: › Disconnect the AC and DC sides and wait at least 5 minutes.

NOTE



The housing of the device does not contain any components which can be repaired by the customer.

Do not attempt to repair faults that are not described in the instructions – “Installing and using the APP”. Contact our customer service department. Only perform the maintenance work that is described here.

The device should be checked for proper operation by a qualified electrician at regular intervals and if you experience problems, you should always contact the system manufacturer’s Service department.

10.2 Cleaning

10.2.1 Cleaning the housing

DANGER



Danger of death due to penetrating fluid.

Serious injuries or death can result if moisture enters the system.

- › Only use completely dry objects to clean the device.
- › The device should only be cleaned from the outside.

CAUTION



Damage to the housing parts when using cleaning agents!

- › If the device is soiled, only clean the housing, cooling fins, housing cover and display with water and a cloth.

1 Use a vacuum cleaner or a soft brush to remove dust from the top of the device on a regular basis.

2 Remove dust from the ventilation inlets if necessary.

10.2.2 Cleaning the heat sink

Do not attempt to eliminate faults that are not described here (in the chapter on troubleshooting). Contact our customer service department. Only perform maintenance work that is described here.

Have the proper operation of the device checked at regular intervals by a qualified electrician and always contact the service department of the system manufacturer in case of problems.

↻ Device switched off on integrated DC isolator switch and AC switch.

↻ Keep a suitable brush ready for cleaning.

1 Clean the free space between the cover and the heat sink using suitable brushes.

2 Clean the heat sink for the air inlet and outlet with a suitable brush.

NOTE: Do not use any aggressive cleaning agents and ensure that no other components come into contact with fluids.

» Cleaning completed



NOTE

Refer to our service and guarantee conditions on our website.

The cleaning intervals must be adapted to the environmental conditions of the installation site.

› In sandy environments, we recommend cleaning the heat sinks every three months.

10.3 Shutting down for maintenance work / troubleshooting

DANGER



Lethal voltages are still present in the connections and cables of the device even after the device has been switched off and disconnected!

Coming into contact with the lines and/or terminals/busbars in the device can cause serious injury or death.

Only appropriately qualified electricians authorised by the mains supply network operator are permitted to open and maintain the device.

› Comply with all safety regulations and current technical connection specifications of the responsible power supply company.



NOTE

If the malfunction light comes on, follow the instructions in the document "Instructions - Installing and using the APP"

↻ NOTE: Shutdown sequence.

1 Switch off the grid voltage by turning off the external circuit breakers.

2 Switch off the DC supply using the DC isolator switch.

DANGER! The DC cables are still live!

» After shutdown, wait 25 minutes before replacing the device.

10.4 Troubleshooting

In <Communication unit properties>, a pending error is displayed under <Live values>. The error relates to the connected <Master inverter>

Error code	"N/A" is displayed here if no error has occurred.
------------	---

10.5 Error code

The following solutions are recommended when the error code is displayed:

No.:	
No.: E03	Description
Step	Relay check Fail
1	Check the DC side condition (e.g. input voltage, poor contact, etc.) and remove any abnormality.
2	Disconnect EPS to check grid condition(e.g. voltage, frequency, poor condition, etc) and remove any abnormality, then restart it to check if the fault is disappear;
3	Make exchange of the inverter if complete the above guide with fault is still there.
No.: E04	Description
Step	DC Injection High
1	Check DCI protection limit and adjust it to be 2A to observe is the fault disappear?
2	If the fault is still there, Check the grid condition(e.g., voltage, frequency, poor contact, etc.)
3	Test the surrounding environment for the presence of high-power equipment (e.g., generators, cranes, etc.), this fault may be related to the start and stop of this equipment.
4	Make exchange of the inverter if complete the above guide with fault is still there.
No.: E05	Description
Step	The result of self-test is fail
1	Disconnect the inverter from the AC grid, PV module and battery and reconnect after 5 minutes.
2	Make exchange of the inverter if complete the above guide with fault is still there.
No.: E08	Description
Step	The AC-side current sensor fails
1	Disconnect the inverter from the AC grid, PV module and battery and reconnect after 5 minutes.
2	Make exchange of the inverter if complete the above guide with fault is still there.
No.: E09	Description
Step	GFCI Device Failure
1	Disconnect the inverter from the AC grid, PV module and battery and reconnect after 5 minutes.
2	Make exchange of the inverter if complete the above guide with fault is still there.
No.: E10	Description
Step	The inverter temperature too low
1	Disconnect the inverter from the AC grid, PV module and battery and reconnect after 5 minutes.

2	If this fault is still being shown, contact the service.
3	The inverter temperature should be above -40°C
No.: E12	Description
Step	HW output over current
1	Disconnect the inverter from the AC grid, PV module, battery and reconnect after 5 minutes, check is it solved?
2	If not, disconnect the load, and restart the inverter to check is it solved?
3	If the fault disappear, then connect the load one by one to check which load result this fault?
4	Make exchange of the inverter if complete the above guide with fault is still there.
No.: E33	Description
Step	Fac Out of Range
1	Check the grid and EPS frequency and observe how often major fluctuations occur.
2	Contact customer service if EPS frequency abnormal.
3	If this fault is caused by frequent fluctuations, try to modify the operating parameters after informing the grid operator first.
No.: E34	Description
Step	AC Voltage Out of Range
1	Check the grid voltage and grid connection on inverter.
2	Check the grid voltage at the point of connection of inverter.
3	If the grid voltage is outside the permissible range due to local grid conditions, try to modify the values of the monitored operational limits after informing the electric utility company first.
No.: E36	Description
Step	System leakage rms current over range
1	Make sure the inverter is reliably grounded.
2	Only Disconnect PV module and restart it to check is the fault on? Remove any abnormality.
3	Only Disconnect battery to check is the fault on? Remove any abnormality.
4	Only Disconnect Grid side to check is fault on? Remove any abnormality.
5	Disconnect EPS to check is fault on? Remove any abnormality.
No.: E37	Description
Step	PV Over Voltage
1	Check the open-circuit voltages of the strings and make sure it is below the maximum DC input voltage of the inverter.
2	Make exchange of the inverter if the input voltage lies within the permitted range and the fault still occurs.

No.: E38	Description
Step	Isolation Fault
1	Make sure the inverter is reliably grounded.
2	Only Disconnect PV module and restart it to check is the fault on? Remove any abnormality.
3	Only Disconnect battery to check is the fault on? remove any abnormality.
4	Only Disconnect Grid side to check is fault on? remove any abnormality.
5	Disconnect EPS to check is fault on? remove any abnormality.
No.: E40	Description
Step	Over temperature in inverter
1	Check whether the airflow to the heat sink is obstructed.
2	Check whether the ambient temperature around the inverter is too high.
No.: E48	Description
Step	The average of ten minutes is overvoltage
1	Check the grid voltage at the point of connection of inverter.
2	If the grid voltage is outside the permissible range due to local grid conditions, try to modify the values of the monitored operational limits after informing the electric utility company first.
3	If the grid voltage lies within the permitted range and this fault still occurs, please call service.
No.: E69	Description
Step	NS protection input signal fault
1	If NS protection function is not needed, this function maybe enabled by mistake, disable this by APP
2	If NS protection function is needed, check signal wire connection is right on RJ45's PIN7&PIN8, if connection is right, use multimeter measure RJ45's PIN7&PIN8 power voltage should lie in range of 8~24Vd.c..
No: W34/ W36/W38	Description
Step	PV1/PV2/PV3 input over current-software
1	Disconnect the inverter from the AC grid, PV module and battery, and reconnect after 5 minutes to check is the problem solved?
2	Make exchange of the inverter if complete the above guide with fault is still there.
No: W35/ W37/W39	Description
Step	PV1/PV2/PV3 input over current-hardware
1	Disconnect the inverter from the AC grid, PV module and battery, and reconnect after 5 minutes to check is the problem solved?
2	Make exchange of the inverter if complete the above guide with fault is still there.

No.: W40	Description
Step	BUS over voltage-software
1	Check actual PV input voltage & AC voltage to make sure the voltage within the voltage range when installing the inverter;
2	If the fault reports during the inverter first installation, and also doesn't work for more than 6 months after production, then the fault may be caused by energy lack of capacitance. Then close the DC switch to charge the capacitor for one day to check is the problem solved? Make exchange of the inverter if it is not solved.
3	Go to next steps to check when it is not new installation
4	Check BUS voltage in cloud;
5	If BUS voltage is over 1050V when PV input voltage is most same with 1000V, please decrease input voltage to check is the fault disappear?
No.: W42	Description
Step	BUS voltage unbalance (for three phase inverter)
1	Check actual PV input voltage & AC voltage to make sure the voltage within the voltage range when installing the inverter;
2	If the fault reports during the inverter first installation, and also doesn't work for more than 6 months after production, then the fault may be caused by energy lack of capacitance. Then close the DC switch to charge the capacitor for one day to check is the problem solved? Make exchange of the inverter if it is not solved.
3	Go to next steps to check when it is not new installation
4	Check BUS voltage in cloud;
5	If BUS voltage is over 1050V when PV input voltage is most same with 1000V, please decrease input voltage to check is the fault disappear?
No.: W45	Description
Step	Output over current-software
1	Disconnect load to check is the warning still on? and remove any abnormality
2	Disconnect battery to check is the warning still on? and remove any abnormality
3	Disconnect PV module to check is the warning still on? and remove any abnormality
4	Make exchange of the inverter if complete the above guide with fault is still there.
No.: W46	Description
Step	Output over current-hardware
1	Disconnect load to check is the warning still on? and remove any abnormality
2	Disconnect battery to check is the warning still on? and remove any abnormality
3	Disconnect PV module to check is the warning still on? and remove any abnormality
4	Make exchange of the inverter if complete the above guide with fault is still there.
No.: W47	Description
Step	Anti-islanding
1	This warning may occurs when grid frequency or voltage instant un-stable or grid blackout occasionally.

2	If this warning occurs frequently, contact service.
No.: W70	Description
Step	Battery Current High(sw)
1	Disconnect the inverter from the AC grid, PV module and battery, and reconnect after 5 minutes to check is the problem solved?
2	Make exchange of the inverter if complete the above guide with fault is still there.
No.: W72	Description
Step	Battery Current High(hw)
1	Disconnect the inverter from the AC grid, PV module and battery, and reconnect after 5 minutes to check is the problem solved?
2	Make exchange of the inverter if complete the above guide with fault is still there.
No.: W75	Description
Step	Battery Voltage High(sw)
1	Check whether the number of batteries exceeds the limit ;
2	Disconnect the battery to check is the problem solved.
No.: W79	Description
Step	PV Start Up Over Voltage
1	Check PV input voltage, the maximum is not higher than 1050V.
No.: W162	Description
Step	DC offset current abnormal
1	Disconnect the inverter from the AC grid, PV module and battery and reconnect after 5 minutes.
2	Make exchange of the inverter if complete the above guide with fault is still there.
No.: W175	Description
Step	Battery Soc Low
1	Timely charge the battery, observe SOC value, it is normal if SOC value increases steadily.
2	If SOC value increases uneven, first charge the battery to be full, then make discharge of battery, it can explain battery package is normal when SOC value changing is even, or please make at least one time cycle of full charge and full discharge everyday to observe whether SOC value display is improved.
	If the failure cannot be solved, please contact the service.
No.: W176	Description
Step	Battery Fault Status
1	Check battery status in App;
2	Follow battery status to find battery fault troubleshooting.

No.: W178	Description
Step	EPS Output Over
1	Decrease the load connection to check is this fault disappear?
2	Stop the inverter and restart with no EPS to check is this fault disappear?
3	Make exchange of the inverter if complete the above guide with fault is still there.
No.: W180	Description
Step	PV string inverse
1	Check PV string/Battery positive and negative connection.

10.6 Fault during connection set-up and search

Note: If there is a timeout or a communication failure with its WLAN network, the APP may freeze in an unwanted manner.

We recommend the following approach:

- Check the WLAN connection on the mobile end device. If the connection has been lost, reactivate it in the device settings. The window of the “KACO NH Setup” APP has to be closed completely using the overview of all opened windows, so that the “KACO NH Setup” APP can be restarted.
- If necessary, restart the search using the “Scan” button.
- If the QR code is not recognized, a manual connection to the Communication unit (Connect-NH) can be established in the settings of the WLAN connection on the mobile end device. SSID: Serial number Connect-NH, password: Registration code (both printed on Connect-NH) see Fig. 74.

Note: The current connection status can also be checked using the LEDs on the communication unit. To do this, check the signal status by referring to Chapter 9.5 on page 49

» Faults have been corrected and the status LED on the Communication unit lights up continuously, signalling readiness for operation.

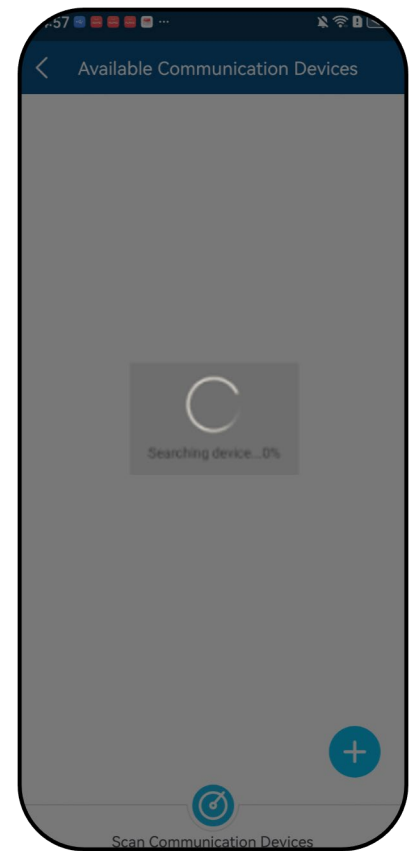

Fig. 234. Fault during connection & search

Note: Inverters can also be searched for and added automatically.

🔄 You have activated the <available inverters> field and not all inverters are displayed.

1. Scan all inverters again using the button.
 2. If no devices are displayed, confirm the <Automatic Reassignment of Modbus Address> selection field.
 3. If an inverter is missing, confirm the selection field >Search Inverters Only<
 4. Once all devices are displayed, you can proceed with configuration.
- » Search successfully completed.

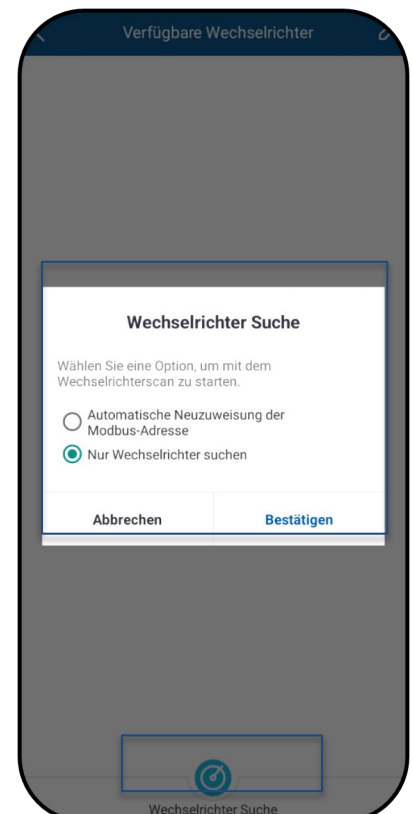

Fig. 235. Search & update inverters

11 Decommissioning and dismantling

11.1 Switching off the device

DANGER

Lethal voltages are still present in the connections and cables of the device even after the device has been switched off and disconnected!

Coming into contact with the lines and/or terminals/busbars in the device can cause serious injury or death.



- › The device must be mounted in a fixed position before being connected electrically.
- › Comply with all safety regulations and current technical connection specifications of the responsible power supply company.
- › The device is only permitted to be opened or serviced by a qualified electrician.
- › Switch off the grid voltage by turning off the external circuit breakers.
- › Check that all AC and DC cables are completely free of current using a clip-on ammeter.
- › Do not touch the cables and/or terminals/busbars when switching the device on and off.
- › Keep the device closed when in operation.

DANGER

Risk of DC plug connectors being destroyed!



DC plug connectors can be destroyed by an arc event if disconnected while still live. It is absolutely essential that the following shutdown sequence be carried out in the correct order:

- › Use a clip-on ammeter to check that there is no current in any DC cables.

WARNING

Risk of burns caused by hot housing components



Housing components can become hot during operation.

- › During operation, only touch the housing cover on the device.

11.2 Disconnecting connections

11.2.1 AC connection

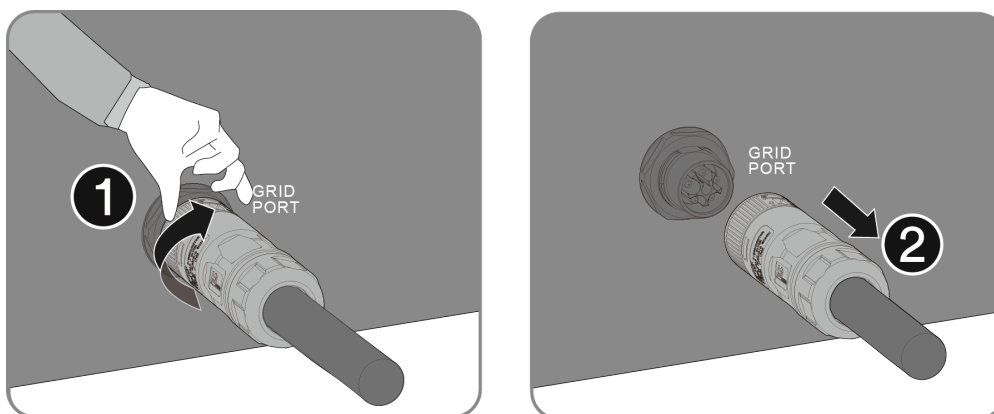

Fig. 236. Loosen and remove AC connector.

⌚ Ensure that the device is completely free of AC/DC voltage.

1. Rotate the latch as shown.
2. Remove the female end of the cable to unlock the account.

11.2.2 Back-up connection

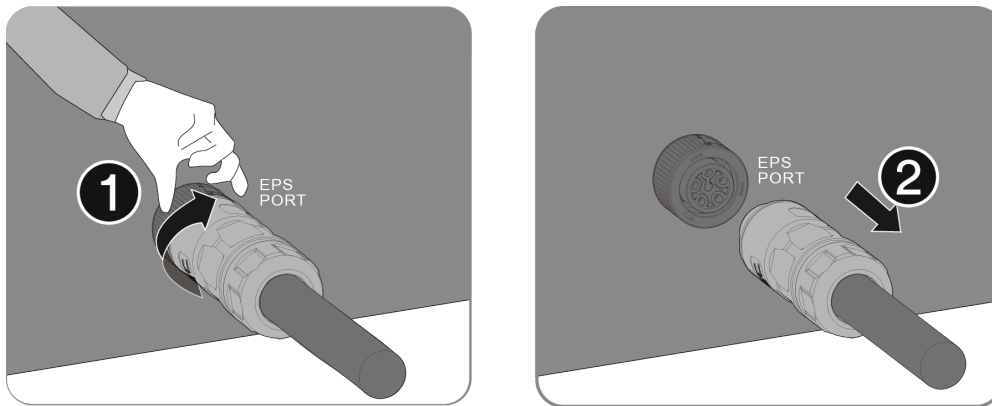

Fig. 237. Loosen and remove Back-up connector.

⌚ Ensure that the device is completely free of AC/DC voltage.

1. Rotate the latch as shown.
2. Remove the female end of the cable to unlock the account.

11.2.3 Battery connection

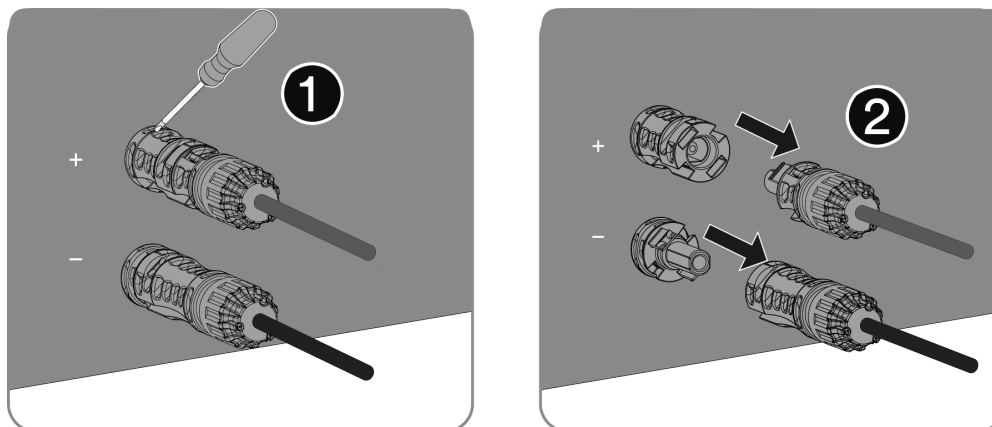

Fig. 238. Loosen and remove the Battery connector.

⌚ Ensure that the device is completely free of AC/DC voltage.

1. Insert a flat-blade screwdriver or an angled screwdriver (blade width: 3.5mm) into one of the side slots.
2. Pull the Battery connector out.

11.2.4 Communication unit connection

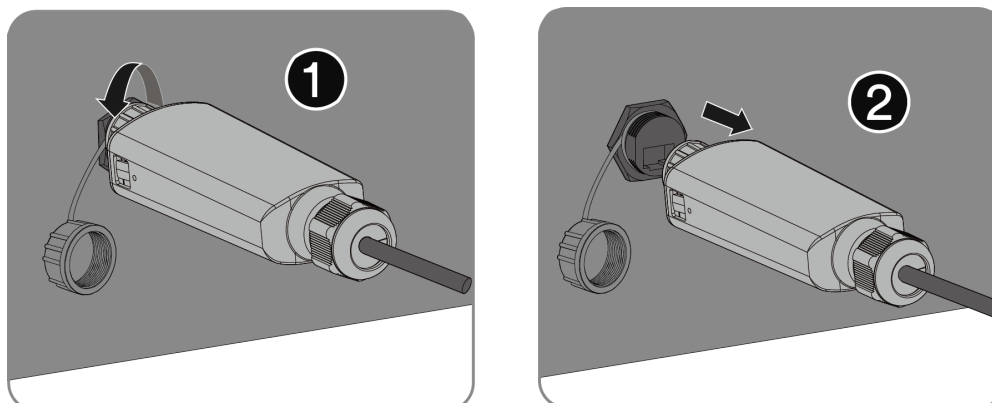

Fig. 239. Rotate and remove the communication unit terminal.

⌚ Ensure that the device is completely free of AC/DC voltage.

1. Rotate the nut of the communication unit as shown.
2. Remove the communication unit to unlock the account.

11.2.5 DC connection

DANGER



Destruction of the DC plug connectors

DC plug connectors can be destroyed by an arc event if disconnected while still live. It is absolutely essential that the following shutdown sequence be carried out in the correct order:

- › Use a clip-on ammeter to check that there is no current in any DC cables.

⌚ Ensure that the device is completely free of AC/DC voltage.

⌚ › Check that there is no current with a clip-on ammeter.

⌚ **NOTE: Plug connectors may be unplugged under voltage, but never under load.**

- 1 Use a screwdriver (blade width 3 mm) to push out the catch on the coupling.
- 2 Leave the screwdriver in place.
- 3 Disconnect the DC connector from the DC socket.
- 4 Remove cables and insert DC contact plug with attached sealing plugs. (see Fig. 238)

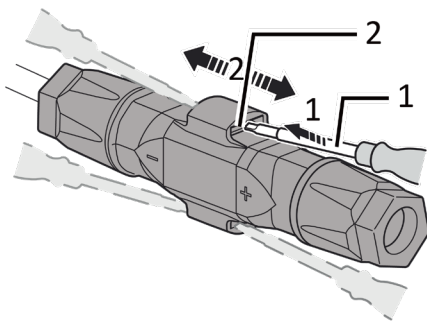

- 1 Screwdriver
- 2 Catch

Fig. 240. Unplug the plug connector

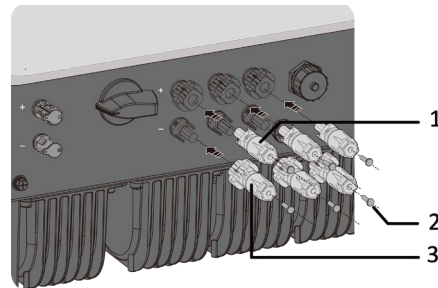

- 1 DC+ contact plug
- 2 Sealing plug
- 3 DC- contact plug

Fig. 241. Seal DC connections

11.3 Uninstalling the device

DANGER



Dangerous voltage due to two operating voltages

Coming into contact with the lines and/or terminals/busbars in the device can cause serious injury or death. The discharge time of the capacitors is up to 5 minutes.

- › Only appropriately qualified electricians authorised by the mains supply network operator are permitted to open and maintain the device.
- › Before opening the device: › Disconnect the AC and DC sides and wait at least 5 minutes.

⌚ Device disconnected and secured against restart.

- 1 Disconnect the AC connection plug from the device. For the AC connection, [see Chapter 11.2.1 on page 109]
 - 2 Detach the DC cables from the DC plug connectors and furnish with protective caps. For the DC connection, [see Chapter 11.2.5 on page 111]
 - 3 Disconnect the Back-up. [see Chapter 11.2.2 on page 110]
 - 4 Disconnect the battery. [see Chapter 11.2.3 on page 110]
 - 5 Disconnect the Communication device. [see Chapter 11.2.4 on page 110]
 - 6 If available, disassemble the accessories: Smart Meter Connection Kit in reverse order according to chapter 7.9.5.
- » The device has been uninstalled. Proceed with disassembly

11.4 Disassembling the device

↻ Unit has been switched off and uninstalled.

- 1 Remove the screw that prevents the device from being lifted off the mount.
- 2 Use the lateral openings and lift the device off the mount.
 - » Device removed. Proceed with the packaging process.

11.5 Packaging the device

↻ Device has been uninstalled.

- 1 If possible, always pack the device in the original packaging. If this is no longer available, an alternative is to use equivalent packaging.
- 2 The packaging box must be fully sealable and suitable for the weight and size of the device.

11.6 Storing the device

CAUTION



Property damage as a result of condensation

Incorrect storage can cause condensate to form in the device and impair the functionality of the device (e.g. storage outside the ambient conditions or temporary relocation from a cold to a hot environment).

- Store in accordance with the technical data > environmental data.
 - › Prior to installation, check the inner area for condensation and if necessary, allow it to dry sufficiently before installation.

↻ Device packaged.

Store the device in a dry place in accordance with the ambient temperature range specified in the environmental data.

12 Disposal

CAUTION



Risk to the environment if disposal is not carried out in the correct manner

For the most part, both the device and the corresponding transport packaging are made from recyclable raw materials.

Unit: Defective devices and accessories must not be disposed of with household waste. Ensure that the old devices and any accessories are disposed of in a proper manner.

Packaging: Ensure that the transport packaging is disposed of properly.

13 Service and warranty

If you need help solving a technical problem with one of our KACO products, please contact our service hotline.

Please have the following information ready so that we can help you quickly and efficiently:

- Device name / serial number
- Date of installation / Start-up report
- Error message shown on the display / Description of the error / Did you notice anything unusual? / What has already been done to analyse the error?
- Module type and string circuit
- Consignment identification / Delivery address / Contact person (with telephone number)
- Information about the accessibility of the installation site.

You will find the following information and other information on our website www.kaco-newenergy.com.

- our current warranty conditions,
- a complaint form,
- a form for registering your device. Please register your device without delay. In this manner, you can assist us in providing you with the quickest service possible.

14 Appendix

14.1 EU Declaration of Conformity

Manufacturer's name and address	KACO new energy GmbH Werner-von-Siemens-Allee 1 74172 Neckarsulm, Germany	
Product description	Hybrid inverter	
Type designation	blueplanet hybrid 6.0 NH3 M2	1002100
KACO art. no.]	blueplanet hybrid 8.0 NH3 M2	1002101
	blueplanet hybrid 8.0 NH3 M3	1002104
	blueplanet hybrid 10.0 NH3 M2	1002102
	blueplanet hybrid 10.0 NH3 M3	1002105
	blueplanet hybrid 12.0 NH3 M2	1002103
	blueplanet hybrid 12.0 NH3 M3	1002106

The subject matter of the declaration described above complies with the relevant legal requirements set out in the European Union Directive of 26 February 2014 on the approximation of the laws of the Member States relating to electro-magnetic compatibility (2014/30/EU), the Low Voltage Directives (2014/35/EU) and of 16 April 2014 the Radio Equipment Directive (2014/53/EU).

The item is compliant with the following standards:

2014/35/EU	Safety of the device
"Directive relating to electrical equipment designed for use within certain voltage limits"	EN 62109-1:2010 EN 62109-2:2011
2014/30/EU	Interference immunity
"Directive relating to electromagnetic compatibility"	EN 61000-6-2:2005+AC:2005 EN IEC 61000-6-2:2019 EN 62920:2017 Class A EN 62920:2017+A11:2020 Emitted interference EN 55011:2016 + A1:2017 + A11:2020 + A2:2021 group 1, Class B EN 61000-6-3:2007 + A1:2011 + AC:2012 EN IEC 61000-6-3:2021 EN 62920:2017 Class B EN 62920:2017/A11:2020 EN IEC 62040-2:2018 Secondary effects on the grid EN 61000-3-12:2011 EN IEC 61000-3-11:2019 EN 61000-3-11:2000
2011/65/EU	RoHS
"Directive on the restriction of the use of certain hazardous substances in electrical and electronic equipment"	EN IEC 63000:2018 (Technical documentation for the assessment of electrical and electronic equipment with regard to the restriction of hazardous substances)
2014/53/EU	Effective Use of the Frequency Spectrum (Regulation 3(2))
"Radio Equipment Provision Directive"	EN 300 328 V2.2.2 Safety and Health (Regulation 3(1)(a)) EN IEC 62311:2020 Electromagnetic Compatibility (Regulation 3(1)(b)) EN 301 489-1 V 2.2.3 EN 301 489-17 V 3.2.4

The types mentioned above are therefore labelled with the CE mark.

Unauthorised modifications to the supplied devices and/or any use of the devices that is contrary to their intended use render this Declaration of Conformity null and void.

This Declaration of Conformity is issued under the sole responsibility of KACO new energy GmbH.

Neckarsulm, 16.05.2024

Neckarsulm, 16.05.2024



3016621-04-250430

The text and figures reflect the current technical state at the time of printing. Subject to technical changes. No liability for printing errors.